



# Aluminium folding sliding shutters

## EFSL system



## Installation instructions

INSTALLATION BY  
SPECIALIST PERSONNEL  
Valid from 05.2017

E 633.1

---

## Notes

These installation instructions describe the installation and commissioning of EHRET EFSL folding sliding shutters.

These installation instructions are a component part of the product and are therefore always to be retained until the product is disposed of.

These installation instructions are to be passed along in the event of the sale of this product.

These instructions are addressed to qualified specialist personnel. Qualified specialist personnel are persons who are familiar with the transport, set-up, installation, commissioning and operation of the product and who have appropriate qualifications for their work.

Specialist personnel must know and observe the relevant standards and/or guidelines.

This product complies with the general rules of technology. Safety-conscious behaviour is necessary for commissioning the product safely. For this reason, observe the following notes.

Carefully read through these instructions prior to commissioning. Observe the specified process steps and take into account the notes and recommendations given. Knowledge of and technically impeccable implementation of the given safety notes and warnings are prerequisites for safe and proper operation of the folding sliding shutters. Insufficient knowledge at the time of commissioning and utilisation lead to the loss of any liability claims against EHRET GmbH. Any installation or operation in deviation from our installation and operating instructions – either in full or in part – will result in the warranty becoming void.

Should any of the information in these installation instructions not be absolutely clear, it is essential that you contact the specialist personnel at EHRET GmbH, 77972 Mahlberg (Germany).

Bore hole sizes and fastening material are recommendations only and may vary depending on the substrate!

---

# Contents

Notes . . . . .	2
Explanation of signs and symbols . . . . .	4
Safety notes . . . . .	4
<b>CE</b> EC Declaration of Conformity . . . . .	6
Installation FAQs. . . . .	7
Disposal . . . . .	9
<b>1 Product description</b>	
Tools required . . . . .	10
Alignment of the fittings. . . . .	11
Top and bottom guide rails . . . . .	12
Top fittings. . . . .	13
Bottom guides. . . . .	14
Additional parts . . . . .	15
<b>2 Installation instructions</b>	
Preparation. . . . .	18
Mounting the top guide rail and running mechanisms . . . . .	18
Drilling rail ends . . . . .	19
Inserting the top running mechanisms into the top guide rail . . . . .	20
Mounting the bottom guide rail and guides . . . . .	22
Connecting the folding sliding shutters to the top running mechanisms . . . . .	24
Inserting guide rollers into the bottom guide rail . . . . .	25
Connecting the folding sliding shutters to the bottom guides . . . . .	26
Aligning and fixing the sashes. . . . .	27

## Explanation of signs and symbols

### Warning notes

 <b>DANGER</b>
▶ Designates an imminent danger that could lead to death or severe injuries if the respective precautionary measures are not implemented.

 <b>WARNING</b>
▶ Means that death, severe bodily injury or major property damage could occur if the respective precautionary measures are not implemented.

 <b>CAUTION</b>
▶ Means a possible danger that could lead to minor injuries or property damage if it is not avoided.

- ▶ Directives for action

## Safety notes

- ▶ Only qualified specialist personnel may carry out installation and commissioning!

 <b>WARNING</b>
<b>Incorrect installation could lead to severe injuries and/or damage to property.</b>
▶ Follow all installation instructions.

 <b>WARNING</b>
▶ Take into account the following notes and warnings in order to avoid dangers and to protect the product.

- ▶ Observe the accident prevention regulations of the Accident Prevention & Insurance Association.
- ▶ Observe the rules of the road during transport.
- ▶ Make sure that the load is well-secured on the means of transport.
- ▶ Cordon off a generously large area around the installation site.
- ▶ Observe without limitation the regulations of the manufacturers of dowel and fitting materials.
- ▶ The mounting bases of the installation site are to be checked for load-bearing capacity prior to installation.
- ▶ In the event of uncertainties about the mounting bases, contact your responsible building experts.
- ▶ Check the product for damage prior to installation. Products requiring repair may not be used.

- ▶ No personnel or obstacles are permitted to be within the range of pivoting and/or travelling shutters while they are moving. Keep personnel and objects away until the shutters have reached their final position.
- ▶ Do not reach into moving parts or closing areas while shutters are opening or closing.
- ▶ Make sure that no articles of clothing or body parts are able to be caught by moving parts in the system.
- ▶ Ice could form on the product in the event of snowfall, sleet or icy rain. Do not operate equipment until the ice is no longer present.
- ▶ Make sure that the shutters are locked before any wind load occurs.
- ▶ The shutters may not be operated at wind speeds from 62 km/h (stormy wind).
- ▶ No additional loads such as persons or objects are permitted to have an effect on the shutters.
- ▶ Shutters are not intended to protect individuals from falls.

** WARNING****Danger of injury from the weight of the product!**

- ▶ Due to the weight of the products, transport and installation must be carried out by at least two individuals.

- ▶ Transport the product carefully in order to avoid damage.
- ▶ Take care to ensure that the product is not damaged when the packaging material is removed.

** WARNING****Danger of suffocation from packaging foil.**

- ▶ The packaging foil must be kept out of reach of children.
  - ▶ Store the foil carefully until you turn it in for recycling.
- ▶ Turn the packaging materials in for recycling.

## CE EC Declaration of Conformity

(Original EC Declaration of Conformity)

In accordance with the Construction Products Directive 89/106/EEC

**The manufacturer:** EHRET GmbH  
Aluminium shutters  
Bahnhofstrasse 14-18  
77972 Mahlberg, Germany

declares that the product: **EHRET folding sliding shutters with EFSL system**

Description of function: Sun/glare protection and screen

to which this guideline refers, meets the requirements of the EC Directives specified above.

The following harmonised standards have been applied in full:

<b>EN 13659: 2015-05</b>	Shutters and external venetian blinds – Performance requirements including safety
<b>EN 1932: 2013-06</b>	External blinds and shutters – Resistance to wind loads
<b>EN 13527: 1999-10</b>	Shutters and blinds – Measurement of operating force

Name and address of the individual who is authorised to assemble the technical documentation:

Ralf Gielen  
Head of Technology

Location: 77972 Mahlberg, Germany  
Date: 01.05.2017

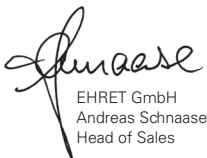

EHRET GmbH  
Andreas Schnaase  
Head of Sales



EHRET GmbH  
Eberhard Schopferer  
Management

## Installation FAQs

### Which parts have been delivered?

- Top guide rail, cut to measure.
- Bottom guide rail, cut to measure.
- Sash packets, each containing two folding sliding sashes.
- Hinges pre-installed on the sash.
- Top pull catches pre-installed on the sash.
- Bottom pull catches and accessory fittings included loose.

### Which means of attachment are being used?



- The fitting materials are not included in the scope of delivery!
- The selection of the fitting materials is based on the mounting bases on hand, the load-bearing capacities of which are to be checked before the installation. Observe without limitation the regulations of the manufacturers of dowel and fitting materials.

#### WARNING

##### **Danger of injury/property damage caused by unsuitable fitting materials**

- ▶ The fitting materials are to be selected in accordance with the load-bearing capacity of the mounting bases.

### Which parts are to be positioned where on the structure?

- Top guide rail: Detailed drawings, see  chapter "Mounting the top guide rail and running mechanisms", page 18.
- Bottom guide rail: Detailed drawings, see  chapter "Mounting the bottom guide rail and guides", page 22.

### How are the folding sliding sashes hooked into the trolleys and how can the sashes be readjusted?

- Position the sash packet between the upper and lower pivot, insert the bolt for the end and pivoting components from above or below and screw in with a head screw.
- The height of sashes can be adjusted via the connection profiles by +/- 5 mm.

#### WARNING

##### **Danger of injury/property damage caused by insufficient screw retention**

If the fastening screws are not tightened firmly, the folding sliding sash can become detached and fall.

- ▶ Make sure that all fastening and safety screws are firmly and securely positioned.

### What distances to the sash are to be observed?

- Distances for guide "rail" and sash to the reveal: Detailed drawings, see  chapter "Mounting the top guide rail and running mechanisms", page 18.

What must be observed during on-site performance?

 **WARNING**

**Danger of injury/property damage caused by falling folding sliding sashes**

Missing or incorrectly set locking parts may result in fitting parts breaking and therefore in the folding sliding sashes falling.

- ▶ Secure the sash packets using the locking parts.

- If there is an odd number of sashes, the side-hung sash must be fastened in its open position using an additional locking part.

 **WARNING**

**Danger of injury/property damage caused by failure to use wind bracing**

- ▶ Secure free-standing side-hung sashes in their open position using additional locking parts.

 **WARNING**

**Danger of injury/property damage caused by sashes that roll over too far**

- ▶ Secure the opened sash packets so that they cannot roll more than 90°. This roll-over protection is to be provided by the customer.

- For roll-over protection, the following items are optionally available to order from EHRET:
  - 10016/10017 Rubber stop buffer white/black;
  - 131616 FSL-light sash lock with bracket for screwing on;
  - 13190-131793 Roll-over protection

What is to be taken into account with the function check?

- Can the folding sliding sashes be moved easily?
- Are the distances from the side of the sashes to the reveal observed?
- Are the folding sliding sashes aligned parallel to one another?



## Disposal



### **IMPORTANT**

#### Disposal

- The following information must be strictly adhered to in order to prevent any environmental damage. Even if the machine is disposed of by certified experts, the operator must ensure proper execution!

Some materials of the machine are reusable. By recycling some parts or raw materials from used products, you make an important contribution to protecting the environment.

- ▶ Please contact your local authorities if you require information about collection points near you.



### **IMPORTANT**

#### Disposal

- ▶ Dispose of any machine parts in such a way that damage to human health and the environment can be excluded.

### Recyclable materials of the machine

Reusable material	Components
Aluminium	<ul style="list-style-type: none"> <li>• Folding sliding shutters</li> <li>• Guide rails</li> <li>• Guides</li> <li>• Additional parts</li> <li>• Fittings</li> </ul>
Plastic, rubber, PVC	<ul style="list-style-type: none"> <li>• Guides</li> <li>• Accessories</li> <li>• Seals</li> </ul>
Steel	<ul style="list-style-type: none"> <li>• Fittings</li> <li>• Fittings of the guides</li> <li>• Accessories</li> </ul>

# 1 Product description

## EFSL system

EHRET folding sliding shutters

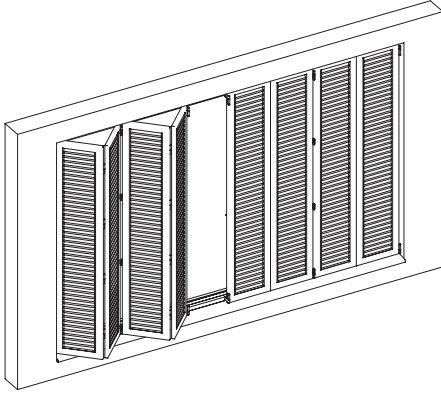

## Tools required

not included in the scope of delivery

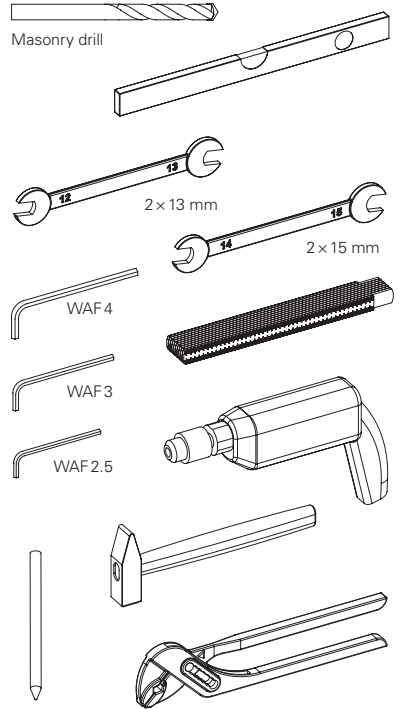

## Alignment of the fittings

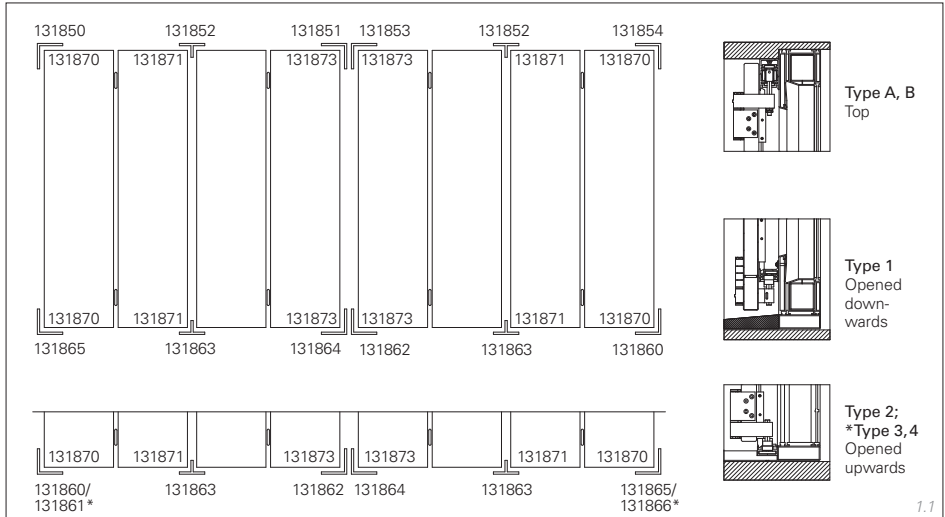

View from inside

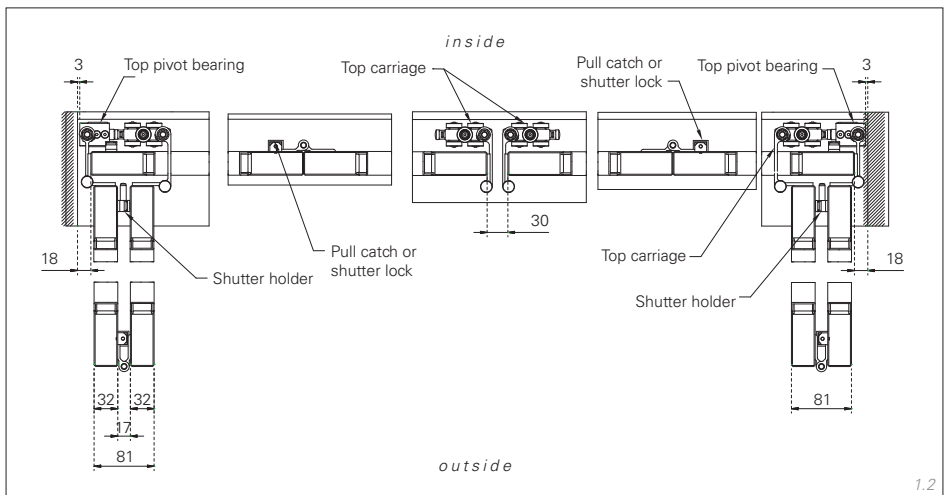

Horizontal section (sample drawing for diagram 2L-2R)

## Top and bottom guide rails

### TOP GUIDE RAIL

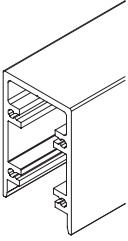

Guide rail ceiling installation, coated  
131802

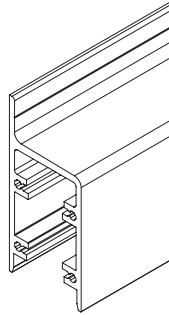

Guide rail wall installation, coated  
131801

### BOTTOM GUIDE RAILS

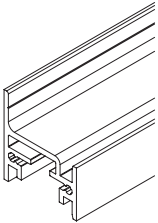

Guide rail type 1+2, coated  
131811

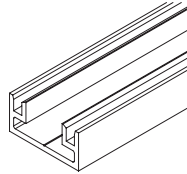

Guide rail type 3+4, coated  
131812

## Top fittings

### CARRIAGES AND SUSPENSION

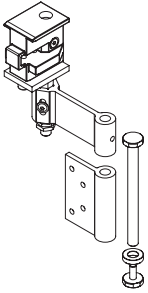

Top-left pivot bearing  
131850

Hinge for pivot bearing  
left and right  
131870

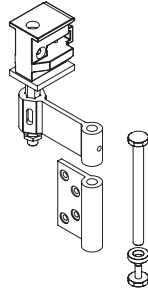

Top-right pivot bearing  
131854

Hinge for pivot bearing  
left and right  
131870

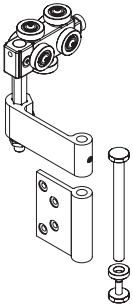

Top-left carriage  
131851

Hinge for left carriage  
131873

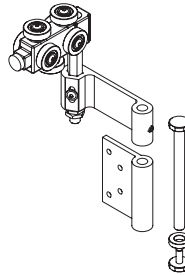

Top-right carriage  
131853

Hinge for right carriage  
131873

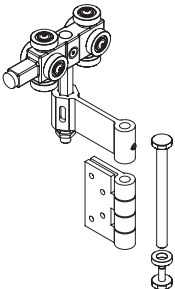

Top-middle carriage  
131852

Middle carriage hinge  
131871

## Bottom guides

### TYPE 1 GUIDES (RAIL OPENED DOWNWARDS)

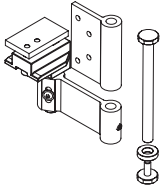

Left pivot bearing  
131865

Hinge for pivot bearing  
left and right  
131870

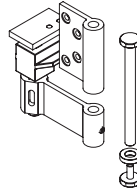

Right pivot bearing  
131860

Hinge for pivot bearing  
left and right  
131870

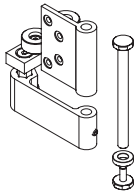

Left carriage  
131864

Hinge for left and right  
carriage  
131873

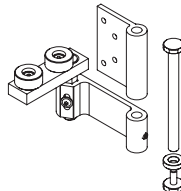

Right carriage  
131862

Hinge for left and right  
carriage  
131873

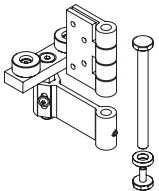

Middle carriage  
131863

Hinge for carriage  
left and right  
131871

TYPE 2-4 GUIDES (RAIL OPENED UPWARDS)

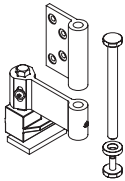

Right pivot bearing  
131865

Hinge for pivot bearing  
left and right  
131870

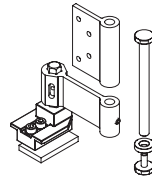

Left pivot bearing  
131860

Hinge for pivot bearing  
left and right  
131870

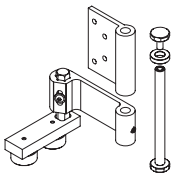

Right carriage  
131864

Hinge for left and right  
carriage  
131873

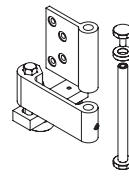

Left carriage  
131862

Hinge for left and right  
carriage  
131873

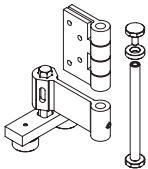

Middle carriage  
131863

Hinge for carriage  
middle  
131871

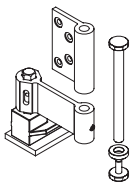

Barrier-free right pivot  
bearing  
131866

Hinge for pivot bearing  
left and right  
131870

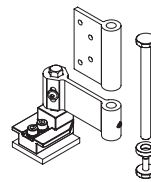

Barrier-free left pivot  
bearing  
131861

Hinge for pivot bearing  
left and right  
131870

## Additional parts

### LOCKING MECHANISMS

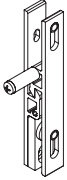

Shutter holder for doors  
with stop block  
131885

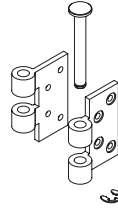

Additional hinge  
for high sashes  
131872

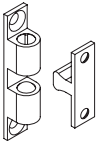

Ball catch  
131750



Pull handle  
131620

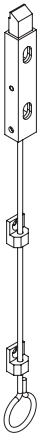

Pull catch  
L = 400 mm  
L = 800 mm  
L = 1300 mm  
131882

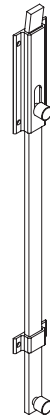

Shutter lock,  
L = 420 mm  
131730  
L = 820 mm  
131731  
L max. = 1520 mm  
131729



## PROTECTION AGAINST FLASHOVER

*option*

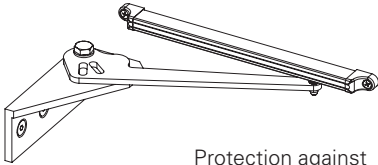

Protection against  
flashover

left, 250 mm

131790

left, 400 mm

131791

right, 250 mm

131792

right, 400 mm

131793



Rubber stop buffer

white

10016

black

10017

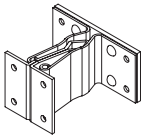

Arrester for shutter with  
bracket

131616

## 2 Installation instructions

### Preparation

#### **⚠ WARNING**

**Danger of injury/property damage caused by unsuitable fastening materials**

- ▶ Select the fastening material in accordance with the load capacity of the installation substrates!

#### **NOTE**

The selection of the fastening method is dependent on the substrate and is therefore exclusively your own responsibility.

- ▶ Open delivery, inspect item for completeness and condition.

### Mounting the top guide rail and running mechanisms

#### **NOTE**

- ▶ When mounting the rails, please take note of whether they are **type A** (header installation) or **type B** (wall installation).

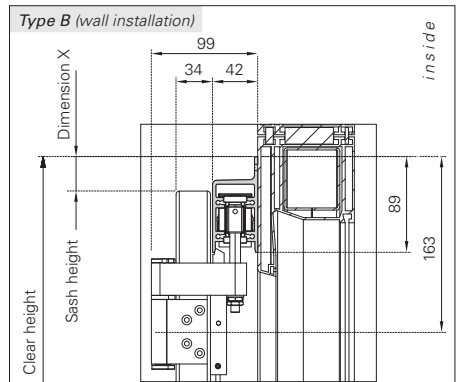
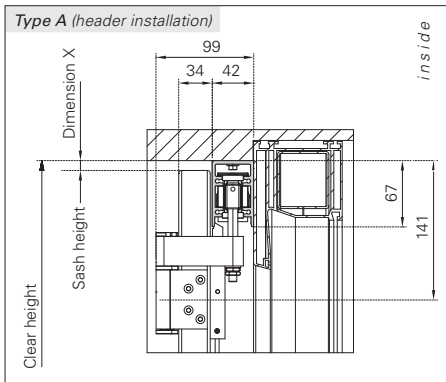

Dimension X = Clear height to top edge of sash

## Drilling rail ends

- ▶ In addition to the grid perforation previously drilled on the rail, drill an additional fixing hole at intervals of 100 mm on the locating faces.

*Fixing hole to be provided by the customer (side with sash packet)*

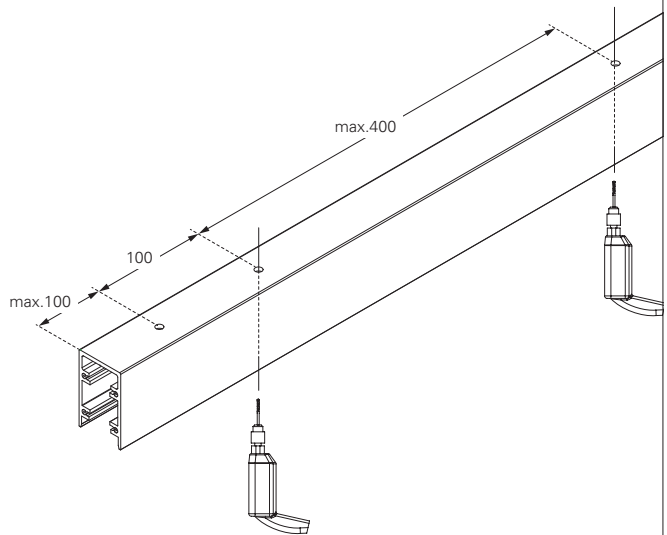

## Inserting the top running mechanisms into the top guide rail

- ▶ Referring to the stop diagram, combine the top running mechanisms and insert into the guide rail.

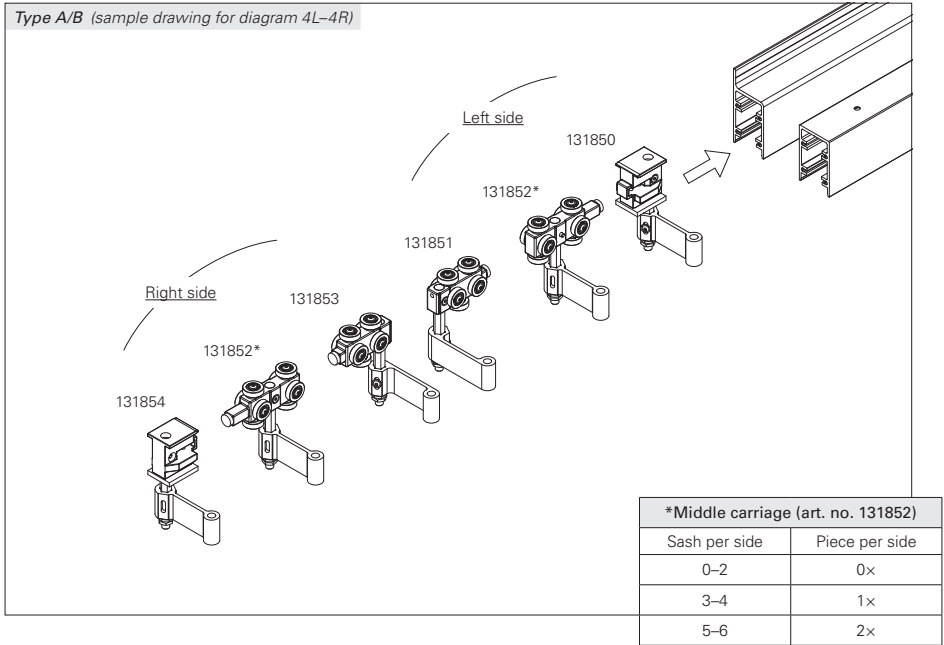

- ▶ Position the upper pivots on each stop side so that there is a distance of 1 mm from the outer edge of the guide rail.

- ▶ Tighten the pivots with an Allen key (WAF 3).

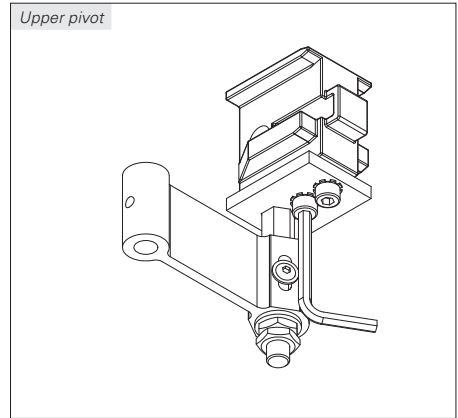
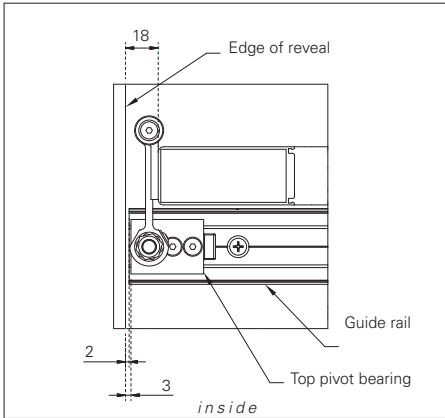

Clearances	
Air (reveal edge to rail)	2 mm
On the side: sash to outer edge of rail	16 mm
On the side: sash to edge of reveal	18 mm
Distance of pivot to rail	1 mm
Sash middle joint	30 mm

- ▶ Position the top guide rail horizontally and secure it in place using the predrilled grid perforation and additional holes.

## Mounting the bottom guide rail and guides

### NOTE

- ▶ When mounting the guide rails, please take note of whether they are **type 1** (opened downwards) or **type 2-4** (opened upwards).

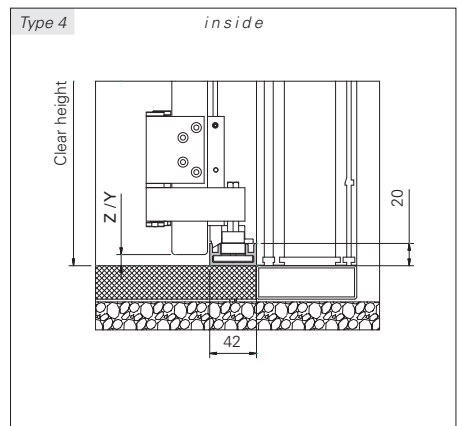
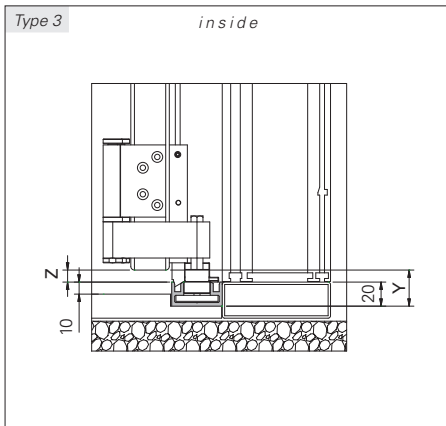
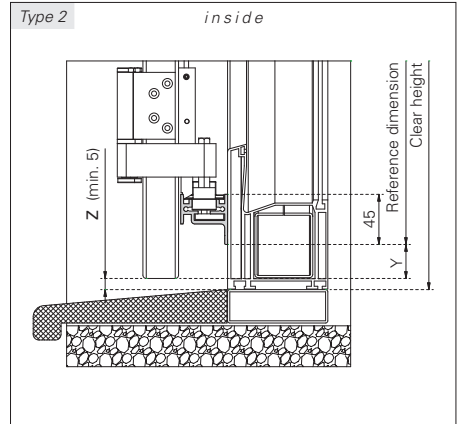
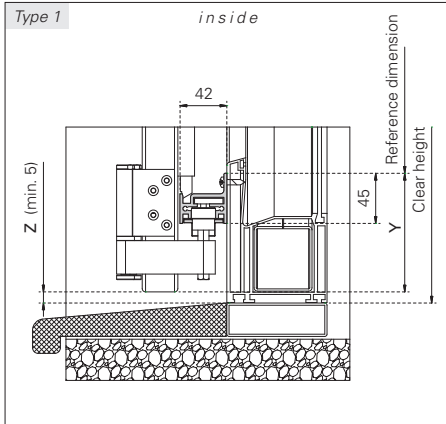

- ▶ Position the pivot bearing in the bottom guide rail at a distance of 1 mm.

- ▶ Tighten the lower pivot bearing with an Allen key (WAF 4).

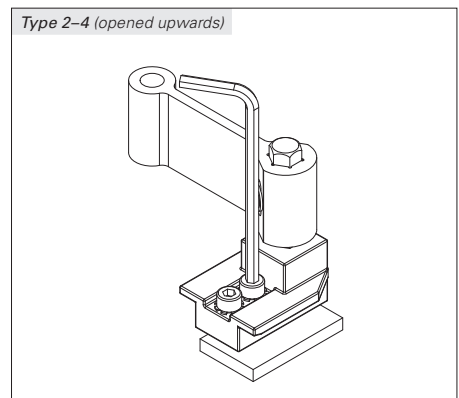
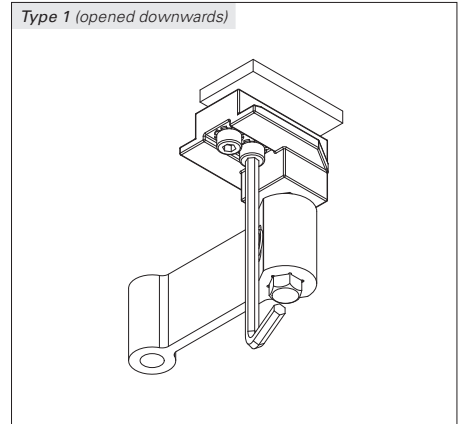
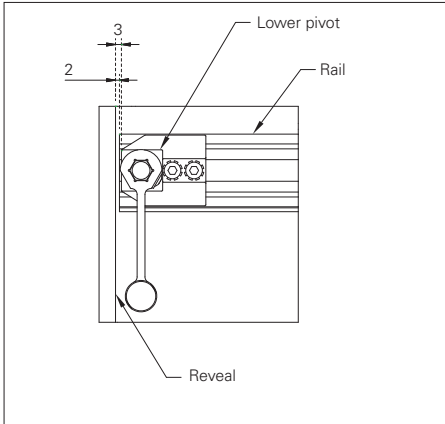

- ▶ Align and mount the bottom guide rail so that it is parallel with the top guide rail.

## Connecting the folding sliding shutters to the top running mechanisms

### NOTE

Please note the position of the thrust washer!

- ▶ Insert the bolts to connect all top running mechanisms and the centre of rotation to the hinges that have already been installed on the folding sliding sashes.
- ▶ Align the folding sliding shutters parallel to one another.

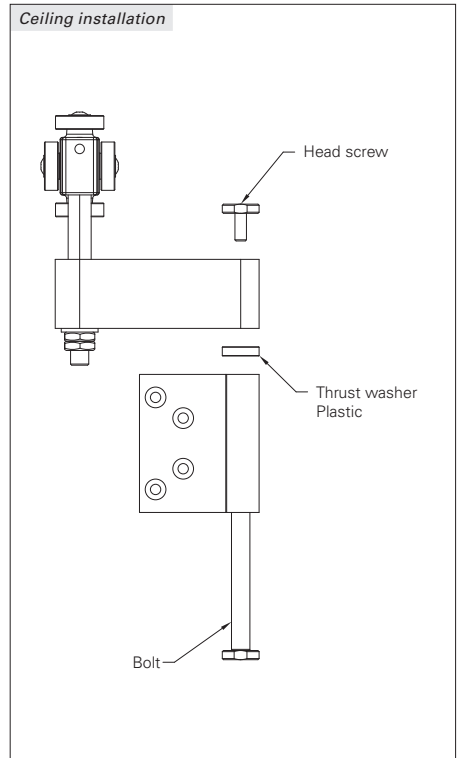
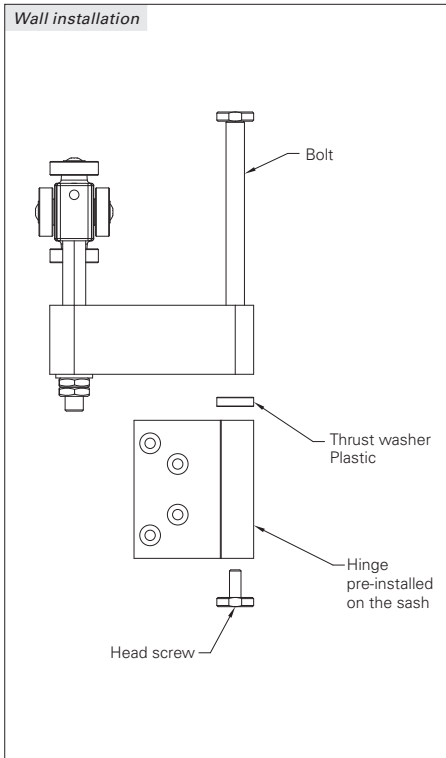



## Inserting guide rollers into the bottom guide rail

- Combine the guide rollers and pivot bearings and insert into the guide rail.

*Type 1 (opened downwards) – sample drawing for diagram 4L–4R*

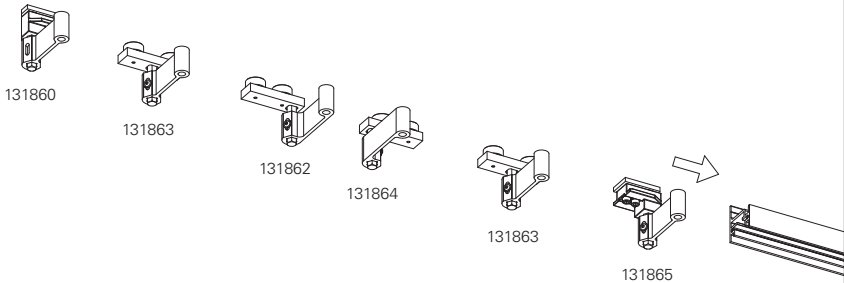

**Middle carriage (art. no. 131863)**

Sash per side	Piece per side
0–2	0x
3–4	1x
5–6	2x

*Type 2–4 (opened upwards) – sample drawing for diagram 4L–4R*

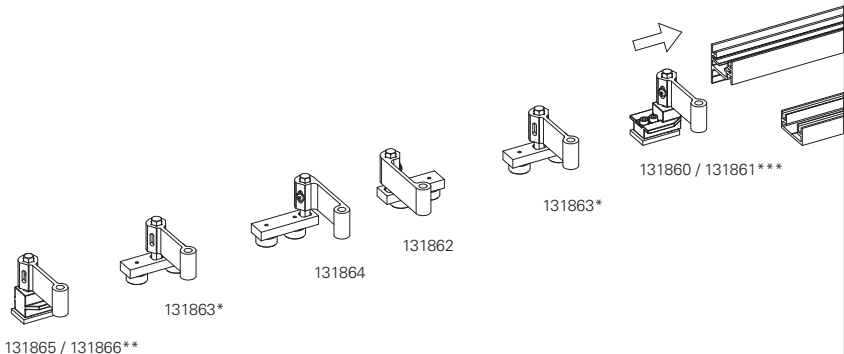

**\*Middle carriage (art. no. 131863)**

Sash per side	Piece per side
0–2	0x
3–4	1x
5–6	2x

\*\* art. no. 131866: Barrier-free right pivot bearing

\*\*\* art. no. 131861: Barrier-free left pivot bearing

## Connecting the folding sliding shutters to the bottom guides

### NOTE

Note the position of the thrust washer!

- ▶ Insert the bolts to connect all bottom running mechanisms and the centre of rotation to the hinges that have already been installed on the folding sliding sashes.
- ▶ Align the sashes
- ▶ Tighten the safety screw bolt
- ▶ Tighten the cap screw

*The cap screws can only be tightened once! When uninstalling the cap screw, it must be replaced by a new one.*

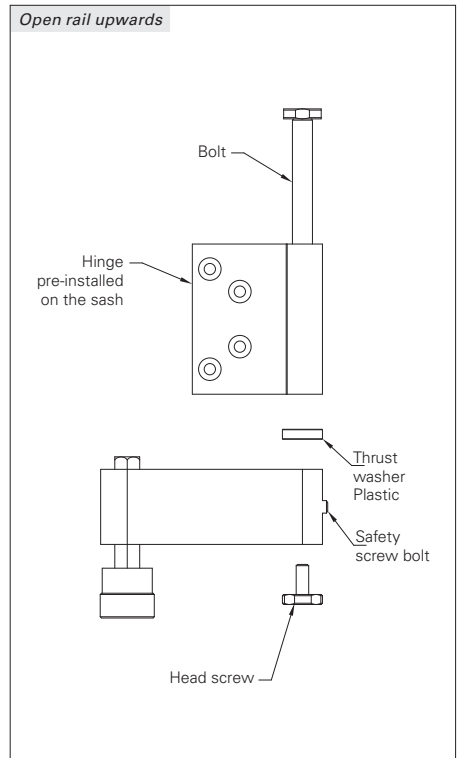
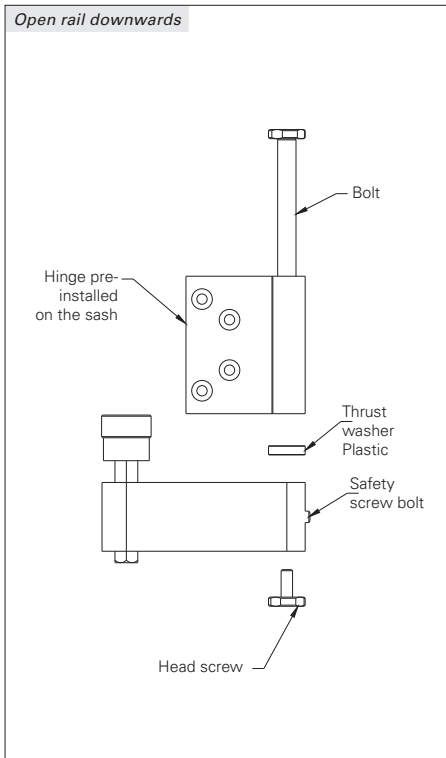

## Aligning and fixing the sashes

- ▶ Adjust the pivot bearings so that the sashes are aligned with one another.
- ▶ Fix the pivot bearings at the top and bottom.

*Align sashes*

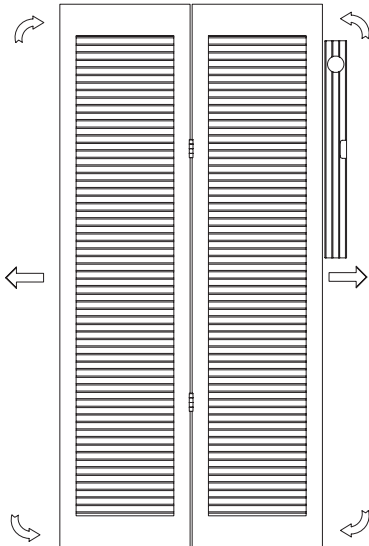

*Top pivot bearing*

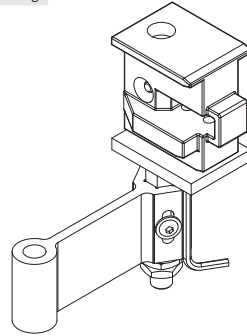

*Bottom pivot bearing*

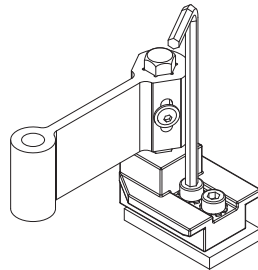

## **EHRET GmbH**

Aluminium shutters

Bahnhofstrasse 14-18

77972 Mahlberg, Germany

Tel. + 49 (0) 78 22/439-0

Fax + 49 (0) 78 22/439-116

[www.ehret.com](http://www.ehret.com)