

MATRICO

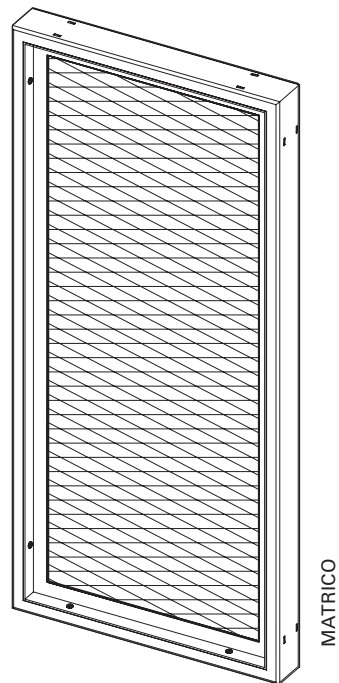

Surface	Fine structure matt (standard), silk gloss, matt Powder-coated 200 °C before assembly
Colours	RAL Classic, RAL Design, NCS, VSR
Finishes	Wood, stone, rust
Notes	Model only on request The method of fastening differs depending on the mesh size of the extending mesh grid, therefore the models can vary visually Drain holes at bottom of frame

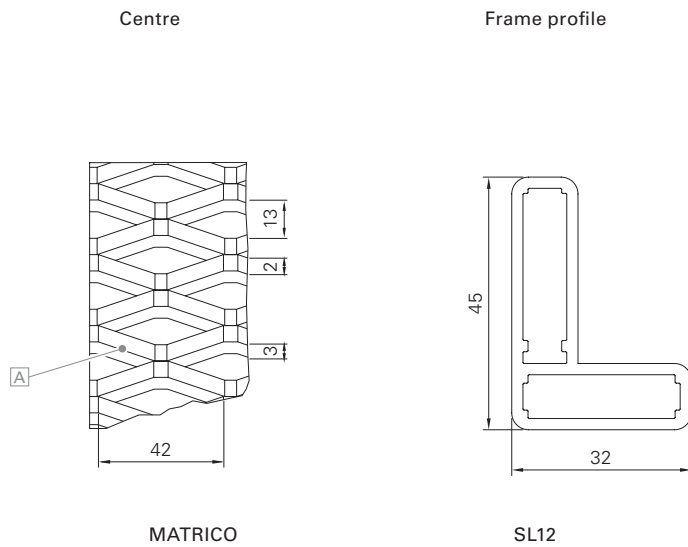



Min./Max. dimensions	Width: 225 to 600 mm Height: 800 to 2500 mm
Weight	Approx. 9 kg/m ²
Frame profile	45 × 32 mm extruded aluminium hollow chamber profile
Fastening profile	30 × 10 × 1.5 mm extruded square tube (with extending mesh grid with small mesh size)
Centre	Extending mesh grid A in accordance with specifications
Corner connections	Glued-in aluminium bracket with visible notch in the outer frame
Options	Pull catch Turning lock Pre-assembly Gap and joint cover Protection against flashover Rail end stop Arrester for shutter with bracket Motorisation MoveTronic