

MATRICO-SL12

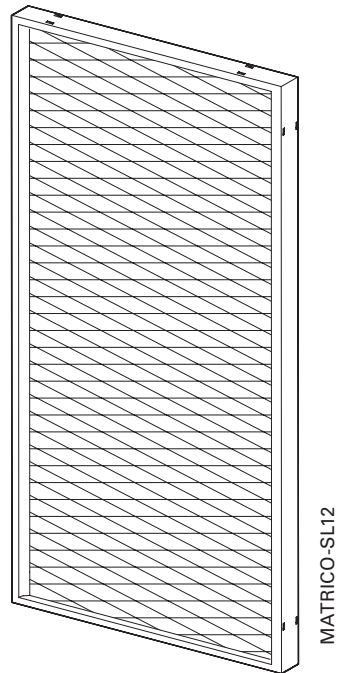

Surface	Fine structure matt (standard), silk gloss, matt Powder-coated 200 °C before assembly
Colours	RAL Classic, RAL Design, NCS, VSR
Finishes (frame)	Wood, stone, rust
Notes	Model only on request The method of fastening differs depending on the mesh size of the extending mesh grid, therefore the models can vary visually Drain holes at bottom of frame

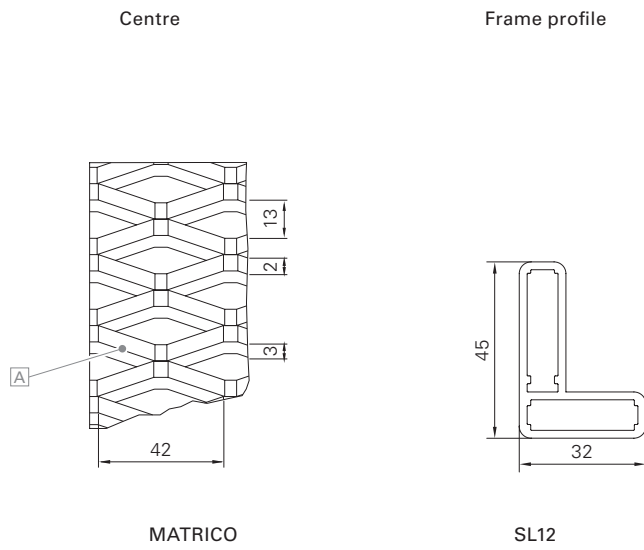



Min./Max. dimensions	Width: 550 to 1250 mm Height: 800 to 3000 mm
Weight	Approx. 9 kg/m ²
Frame profile	45 × 32 mm extruded aluminium hollow chamber profile
Centre	Extending mesh grid A in accordance with specifications
Corner connections	Glued-in aluminium bracket with visible notch in the outer frame
Options	Electric drive