

# PARIS-MAX70

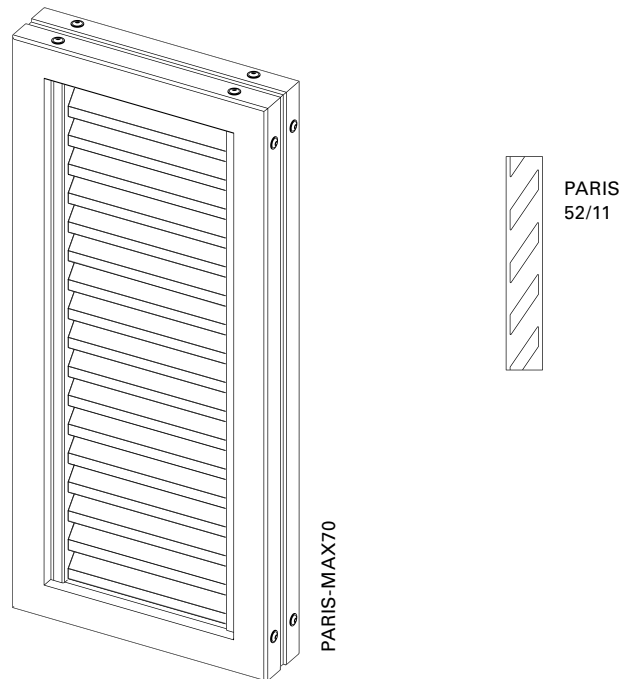

<b>Oberfläche</b>	Feinstruktur-Matt (Standard), Seidenglanz, Matt Pulverbeschichtung 200°C vor dem Zusammenbau
<b>Farben</b>	RAL Classic, RAL Design, NCS, VSR
<b>Dekore</b>	Holz, Stein, Rost
<b>Vorbehandlung</b>	Ocean Line Plus möglich
<b>Hinweise</b>	Entwässerungsbohrung unten im Rahmen Lamellen austauschbar

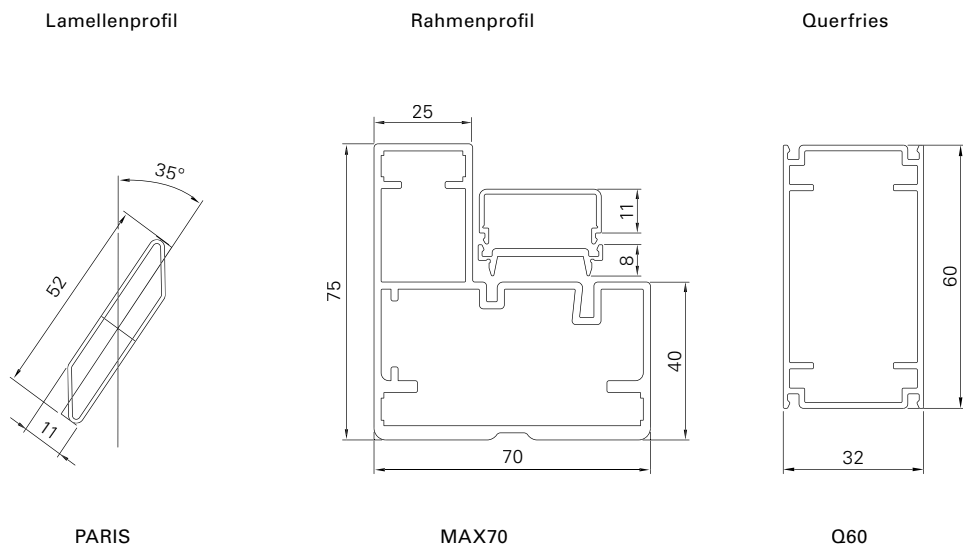



<b>Maße min./max.</b>	Breite: 550 bis 2200 mm Höhe: 800 bis 5500 mm
<b>Vorschub min./max.</b>	40,0–50,5 mm
<b>Neigungswinkel</b>	35°
<b>Gewicht</b>	Ca. 16 kg/m <sup>2</sup>
<b>Rahmenprofil</b>	75 × 70 mm stranggepresstes Aluminiumhohlkammerprofil
<b>Lamellenprofil</b>	52 × 11 mm stranggepresstes Aluminiumhohlkammerprofil
<b>Lamellenträgerprofil</b>	32 × 11 mm stranggepresstes Aluminiumprofil
<b>Zwischenprofil</b>	32 × 8 mm stranggepresstes Aluminiumprofil
<b>Querfriesprofil</b>	60 × 32 mm stranggepresstes Aluminiumhohlkammerprofil
<b>Eckverbindungen</b>	Aluminiumwinkel eingeklebt und zusätzlich verschraubt
<b>Optionen</b>	Längsfries   Querfries   Schiebeladenantriegel   Elektroantrieb