

SL-MAX37

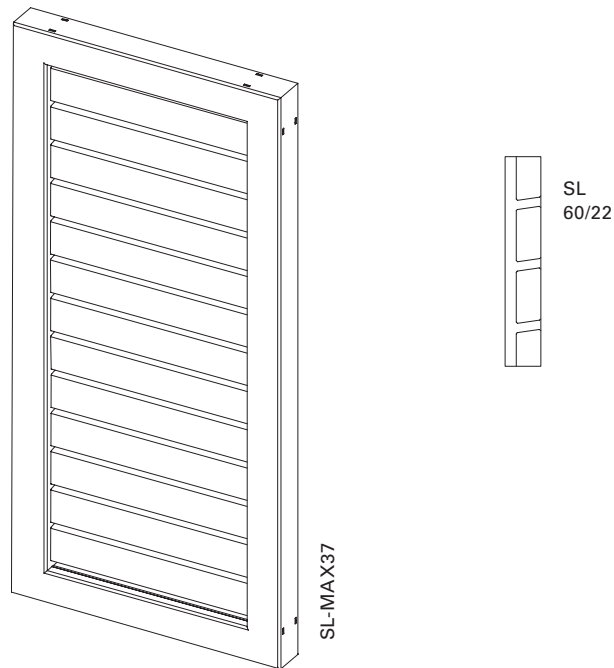

Surface	Fine structure matt (standard), silk gloss, matt Powder-coated 200°C before assembly
Colours	RAL Classic, RAL Design, NCS, VSR
Finishes	Wood, stone, rust
Pretreatment	Ocean Line Plus possible
Notes	Drain holes at bottom of frame Slats are exchangeable

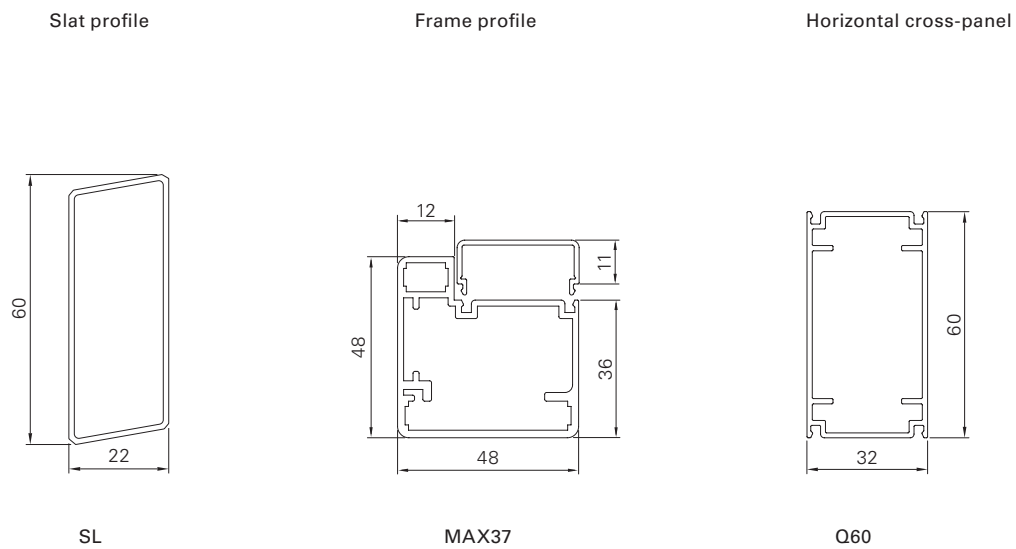



Min./Max. dimensions	Width: 550 to 2200 mm Height: 800 to 3500 mm
Min./max. infeed	Approx. 70,0 – 80,0 mm
Inclination angle	90°
Weight	Approx. 11 kg/m ²
Frame profile	48 × 48 mm extruded aluminium hollow chamber profile
Slat profile	60 × 22 mm extruded aluminium hollow chamber profile
Slat carrier profile	32 × 11 mm extruded aluminium profile
Horizontal cross-panel profile	60 × 32 mm extruded aluminium hollow chamber profile
Corner connections	Glued-in aluminium bracket with visible notch in the outer frame
Options	Vertical cross-panel Horizontal cross-panel Sliding shutter flush bolt Electric drive