

NATURE-SL12-80U

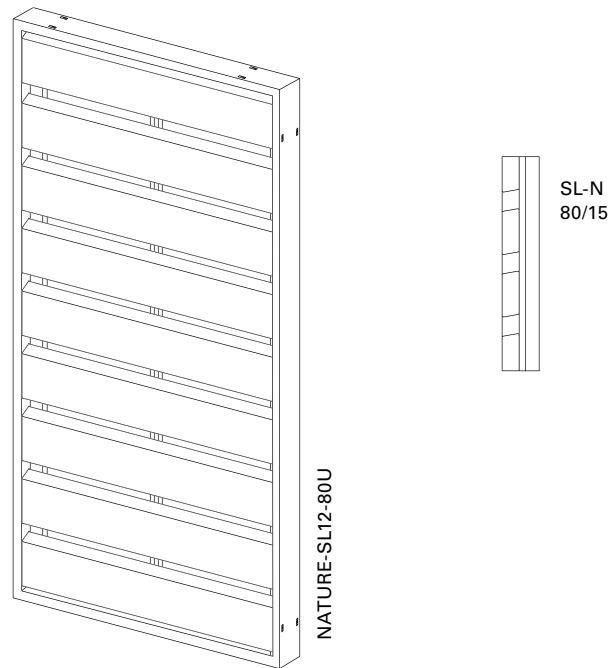

Surface	Solid wood slat, planed Fine structure matt (standard), silk gloss, matt Powder-coated 200 °C before assembly
Type of wood	Siberian larch
Colours	Colours available on request and in accordance with order placement once a sample has been produced and approved
Pretreatment	Untreated; Glazed slats on request
Notes	A support profile is required for widths greater than 801 mm The considerable weight must be taken into consideration when preparing assembly

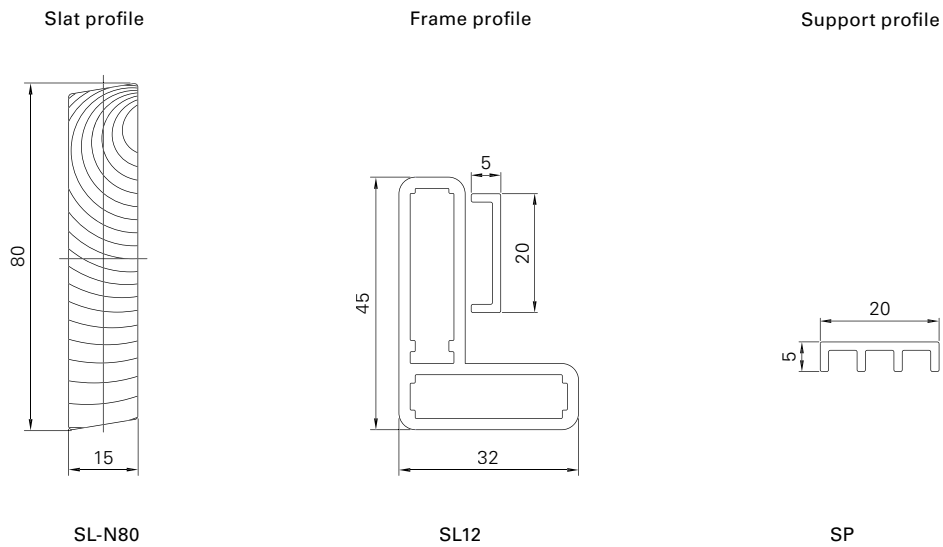

Min./Max. dimensions	Width: 550 to 1600 mm Height: 800 to 3000 mm
Min./Max. infeed	Approx. 90,0–100,0 mm
Weight	Approx. 15 kg/m ²
Frame profile	45 × 32 mm extruded aluminium hollow chamber profile
Slat profile	80 × 15 mm solid wood slat
Slat carrier profile	20 × 5 mm extruded aluminium profile
Support profile	20 × 5 mm extruded aluminium hollow chamber profile
Corner connections	Glued-in aluminium bracket with visible notch in the outer frame
Options	Electric drive