

VOLETRONIC

Motorisation for sliding shutters



Operating instructions

INSTALLATION
SPECIALIST PERSONNEL
Valid from 09.2011

E 917.6

Notes

The present operating instructions describe the commissioning & programming of EHRET sliding shutter drive VOLETRONIC.

It is essential to install the sliding shutter system in accordance with the specifications laid out in the [□ E915 Installation instructions EHRET sliding shutters](#) before commissioning the sliding shutter control.

Carefully read through these instructions prior to commissioning. Observe the specified process steps and take into account the notes and recommendations given. Knowledge of and technically impeccable implementation of the given safety notes and warnings are prerequisites for safe and proper operation of the EHRET sliding shutter control. Insufficient knowledge at the time of commissioning and utilisation lead to the loss of any liability claims against EHRET GmbH. Installation and/or operation in full or partial deviation from our installation and operating instructions will lead to the warranty for defects becoming void.

These operating and maintenance instructions are a component part of the product and are therefore always to be retained until the product is disposed of. These operating and maintenance instructions are to be passed along in the event of the sale of this product.

These instructions are addressed to qualified specialist personnel. Qualified specialist personnel are persons who are familiar with the transport, setup, installation, commissioning and operation of the product and who have appropriate qualifications for their work. Specialist personnel must know and observe the relevant standards and/or guidelines.

This product is in accordance with general rules of technology. Safety-conscious behaviour is necessary for undertaking safe commissioning. Observe for that reason the following notes. Should you not understand something in these Installation & operating instructions unambiguously, do not fail to contact the specialist personnel at EHRET GmbH, 77972 Mahlberg (Germany).

► *Remove the labels stuck to the shutters after installation!*

Bore hole sizes and fastening material are recommendations; these could vary because of the substrate!

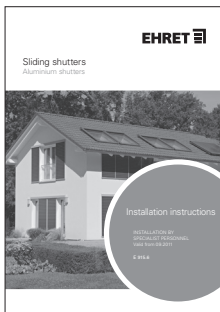

□ E915 Installation instructions | EHRET Sliding shutters

Contents

Notes	2
Explanation of signs and symbols	4
Safety notes	4
Electrical installation	6
Incorrect operation.	7
Behavior at power breakdown	7
Disposal	8
CE EC Declaration of Conformity	9
A VOLETRONIC 230 V serial push-button operation	
Product description	10
Connection.	11
Commissioning	13
Setting the running direction	14
Executing a learning run	15
Setting the speed	16
Setting the force.	17
Impulse/dead man mode	18
B VOLETRONIC 230 V wireless remote control	
Product description	20
Connection.	19
Commissioning	22
Teaching master transmitter.	23
Checking/Changing the running direction	24
Performing a learning run	25
Setting the speed	26
Setting the force.	27
Teaching an additional transmitter.	28
Clearing of an additionally taught transmitter	29
Global clearing of all additionally taught transmitters	30
Group control	31
C VOLETRONIC Solar 12 V wireless remote control	
Product description	34
Connection.	35
Attach solar panel on the cover	36
Attaching the rechargeable battery	37
Commissioning	38
Teaching master transmitter.	40
Monitoring/modification of the direction of travel.	41
Further settings	42
Troubleshooting	43

Explanation of signs and symbols

Warning notes

 **DANGER**

- ▶ Designates an imminent danger that could lead to death or severe injuries if the respective precautionary measures are not implemented.

 **WARNING**

- ▶ Means that death, severe bodily injury or major property damage could occur if the respective precautionary measures are not implemented.

 **CAUTION**

- ▶ Means a possible danger that could lead to minor injuries or property damage if it is not avoided.

- ▶ Directives for action

Safety notes

- ▶ Only qualified specialist personnel may carry out installation and commissioning!

 **WARNING**

Incorrect installation could lead to severe injuries and/or damage to property.

- ▶ Follow all installation instructions.

 **WARNING**

- ▶ Take into account the following notes and warnings in order to avoid dangers and to protect the product.

- ▶ Observe the accident prevention regulations of the Accident Prevention & Insurance Association.
- ▶ Observe the rules of the road during transport.
- ▶ Make sure that the load is well-secured on the means of transport.
- ▶ Take care to ensure that the drives are stored under dry conditions prior to final installation and commissioning.
- ▶ Cordon off a generously large area around the installation site.
- ▶ Observe without limitation the regulations of the manufacturers of dowel and attachment materials.
- ▶ The mounting bases of the installation site are to be checked for load-bearing capacity prior to installation.
- ▶ In the event of uncertainties about the mounting bases, contact your responsible building experts.
- ▶ Electrical work may be carried out only by authorised electricians.

- ▶ The specified connection diagrams are to be observed, as otherwise damage to the motor could occur. EHRET GmbH assumes no liability for damage resulting from incorrect installation.
- ▶ Check the product for damage prior to installation. Products requiring repair may not be used.
- ▶ Do not touch any internal parts of the product that become exposed as the result of damage (e.g. electrical cables/lines).
- ▶ Discontinue operation of your electrical drive at once in the event of smoke or fumes.
- ▶ Do not allow children to play with the operating apparatus of the drives.
- ▶ Electrical/electronic devices are not secure against failure. Make sure that no hazardous situations for personnel or product could arise in the event of a power failure.
- ▶ Devices with electrical controls could go into motion at any time and without warning. Prevent situations hazardous to personnel and product that arise from this fact.
- ▶ No personnel or obstacles are permitted to be within the range of pivoting and/or travelling shutters while they are moving. Keep personnel and objects away until the shutters have reached their final position.
- ▶ Do not reach into moving parts or closing areas while shutters are opening or closing.
- ▶ Make sure that no articles of clothing or body parts are able to be caught by moving parts in the system.
- ▶ Disconnect the drives from the power supply during maintenance work.
- ▶ Ice could form on the product in the event of snowfall, sleet or icy rain. Do not operate equipment until the ice formation is no longer present, and switch automatic controls to manual.
- ▶ Make sure that the shutters are locked before any wind load occurs.
- ▶ The shutters may not be operated at wind speeds from 62 km/h (stormy wind).
- ▶ No additional loads such as persons or objects are permitted to have an effect on the shutters.
- ▶ Shutters are not intended to protect individuals from falls.

 **WARNING**

Danger of injury from the weight of the product!

- ▶ Due to the weight of the products, perform transport and installation by at least two individuals.

- ▶ Transport the product carefully in order to avoid damage.
- ▶ Take care to ensure that the product is not damaged when the packaging material is removed.



 **WARNING**

Danger of suffocation from packaging foil.

- ▶ The packaging foil must be kept out of reach of children.
- ▶ Store the foil carefully until you turn it in for recycling.



- ▶ Turn the packaging materials in for recycling.

Electrical installation

 DANGER	
	Electrical shock (230 V)
<p>▶ The correct installation of the sliding shutter drive may be carried out only by authorised specialist personnel!</p>	

- ▶ At the time of installation, all connections, as shown schematically in the illustration, are to be connected. **The guarantee expires if the Hirschmann plug is removed.**
 - ▶ The connection (Phase L) must be equipped with a line safety switch with a maximum nominal current of 16 A.
 - ▶ The line safety switch must have a switch-off capacity of at least 6 kA.
 - ▶ The prescribed tripping characteristic is B.
 - ▶ The line switch should be equipped with a thermal tripping device for overload protection, furthermore it should have an electromagnetic trigger as a protection against short circuits.
- ▶ Other requirements may apply to the installation of the line safety switch, depending on the location. For example, it could be necessary to use a line safety switch with additional separation of Phase N in order to switch off all poles. It might possibly also be necessary to have a residual current circuit breaker in the system. The standards and the laws of the respective country with respect to permanent electrical installations are to be complied with (e.g. VDE 0100).
 - ▶ It is recommended that no more than 15 drives are secured simultaneously by a single line safety switch.
 - ▶ Pursuant to VDE 0100 and/or the statutory regulations and standards of the respective country, the permanent electrical installation must be carried out by a certified electrician.
 - ▶ According to VDE 0022, the operator and the installer are responsible for compliance with the VDE regulations and/or regulations of the energy supplier.

Incorrect operation

Correct operation can no longer be ensured if the sliding shutter is moved by hand quickly and with great force in its position, and not by means of operation with the  OPEN- or  CLOSE-button.

A force may be applied to the sliding shutter in such cases in such a way that the current mechanical position of the sliding shutter no longer matches the position present in the control.

This leads to incorrect information within the control, as a result of which the control will no longer function correctly.



- ▶ This condition usually is rectified by an ascent and descent run.



Behavior at power breakdown

IMPORTANT

Deletion of reference position due to power failure

Power failure can lead to deletion of the reference position.

- ▶ Move the sliding shutter with push-button  OPEN- or  CLOSE in direction of motor to until the end position. In this position the control system recognize the reference of the normal working.

If the sliding shutter has been in position of reference, at power breakdown, it is necessary to have to move the shutter for and backward with push-button  OPEN- or  CLOSE.

- ▶ After that the function is again guaranteed.

Disposal

 IMPORTANT
<p>Disposal</p> <ul style="list-style-type: none"> • The following information must be strictly adhered to in order to prevent any environmental damage. Even if the machine is disposed of by certified experts, the operator must ensure proper execution!

Some materials of the machine are reusable. By recycling some parts or raw materials from used products, you make an important contribution to protecting the environment.

- ▶ Please contact your local authorities if you require information about collection points near you.

 IMPORTANT
<p>Disposal</p> <ul style="list-style-type: none"> ▶ Dispose of any machine parts in such a way that damage to human health and the environment can be excluded.

Hazardous waste

Reusable material	Components
Electronic waste	<ul style="list-style-type: none"> • Electrical supplies • Control units • Circuit boards with electronic components

Recyclable materials of the machine

Reusable material	Components
Aluminium	<ul style="list-style-type: none"> • Sliding shutters • Suspensions • Guide brackets • Window sill cover • Fittings
Copper	<ul style="list-style-type: none"> • Cables • Motor
Plastic, rubber, PVC	<ul style="list-style-type: none"> • Guides • Accessories • Seals • Cables
Steel	<ul style="list-style-type: none"> • Motor and components • Fittings • Accessories

CE EC Declaration of Conformity

The manufacturer: EHRET GmbH
Aluminium Shutters
Bahnhofstrasse 14 - 18
D - 77972 Mahlberg

erklärt für das Produkt: **VOLETRONIC 230 V sliding shutter drive**
VOLETRONIC Solar 12V sliding shutter drive

to which this guideline refers, is in conformance with the stipulations of

Guideline 1999/05/EC Radio equipment and telecommunications terminal equipment

as well as with the following standards:

EN 301 489-3:2000 Electromagnetic compatibility and Radio spectrum Matters (ERM), Electromagnetic Compatibility (EMC) standard for radio equipment and services – Part 3: Specific conditions for Short-Range Devices (SRD) operating on frequencies between 9 kHz and 40 GHz

EN 300 220-3:2000 Electromagnetic compatibility and Radio spectrum Matters (ERM); Short Range Devices (SRD) radio equipment to be used in the 25 MHz to 1000 MHz frequency range with power levels ranging up to 500 mW – Part 3: Harmonized EN covering essential requirements under Article 3.2 of the R&TTE Directive

98/37/EC Machinery Directive

EN 73/23/EEC Low Voltage Directive

EN 60730 +A1+A2+A11 Safety requirements for automatic electric regulators and
+A12+A13+A14+A15 controllers

—

Name and address of the individual who is authorised to assemble the technical documentation:

Ralf Gielen
Head of Technology

Location: 77972 Mahlberg, Germany
Date: 01/01/2015



EHRET GmbH
Eberhard Schopferer
Management

A VOLETRONIC 230 V | serial push-button operation

Product description

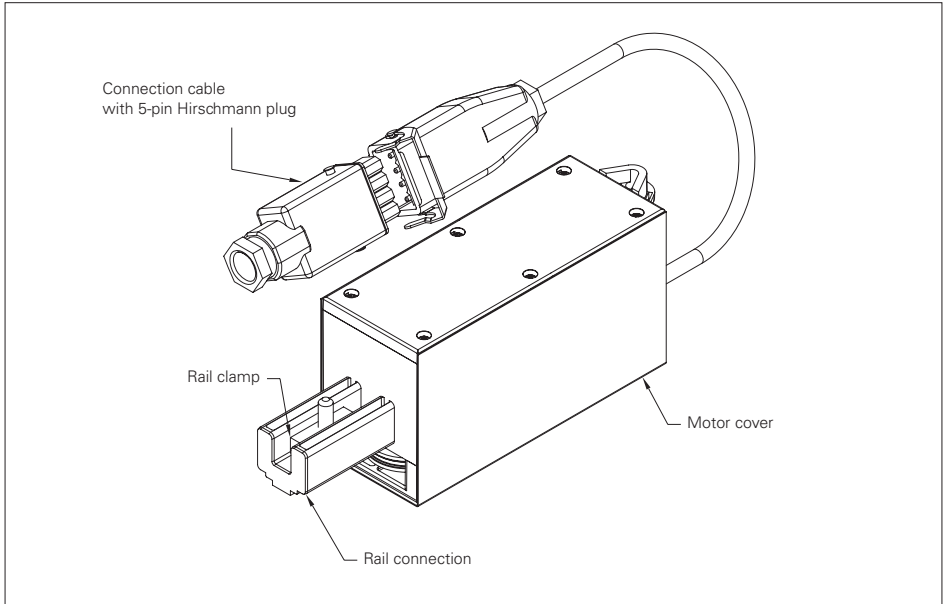

Technical data

<i>Power supply</i>	85 VAC–265 VAC, 50/60 Hz	<i>Torque duration</i>	0.42 Nm 100% ED
<i>Standby</i>	< 0,5W	<i>Short-term permissible torque</i>	0.9 Nm < 1 sec
<i>Max. motor power</i>	approx. 30W	<i>Force detection</i>	Internal speed measuring system (speedometer)
<i>IP type of protection</i>	IP54	<i>Motor gearbox</i>	Transmission ratio 111: 1
<i>Temperature range</i>	–20° C to +60° C	<i>Connection cable</i>	Hirschmann plug, 5-pin
<i>Timeout duration</i>			
Teach-in run	approx. 420 sec		
Normal operation	approx. 240 sec		
<i>Speeds</i>			
Level 1	approx. 2.5 cm/sec		
Level 2	approx. 3.5 cm/sec		
Level 3	approx. 4.5 cm/sec		
Level 4	approx. 5.5 cm/sec		

Connection

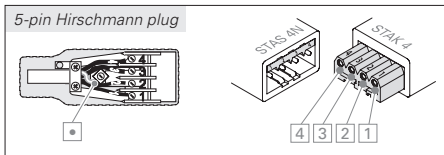
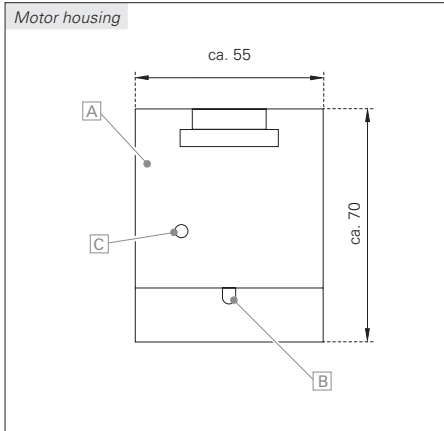

The VOLETRONIC 230 V sliding shutter drive is a drive with integrated control for the actuation of sliding shutters.

- Configurable running speed
- Electronic locking in end position
- Programming of the pick-up position of double bars and acceleration or delay of the running speed at the beginning, the end and in the pick-up range.
- Creep travel upon reaching the start and end position

Motor

- A Motor cover
- B Mains connection 230 V with Hirschmann coupling, 5-pin. The motor is equipped with a 5-pin connection cable with Hirschmann coupling approx. 0.5 m.
- C Monitoring LED on the side of the motor housing (green | yellow | red) used for example for checking the running direction.

5-pin Hirschmann plug

- Earth – protective conductor (green/yellow)
- 1 Mains connection, L-Phase (230 V)
- 2 Mains connection N-neutral conductor (230 V)
- 3 OFF-button signal (230 V)
- 4 ON-button signal (230 V)

Wiring diagram

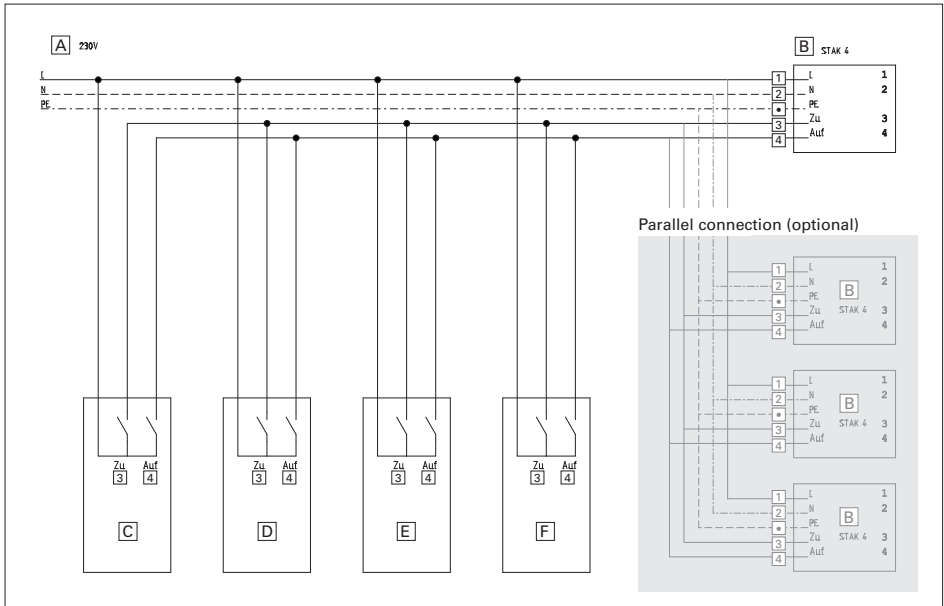

Electrical connection

- A Supply cable 230 V
 - B Hirschmann coupler Stak 4
 - C KNX actor
 - D Push-button or switch
 - E Timer
 - F Sun/wind control
- Earth – protective conductor (green/yellow)
 - 1 Mains connection, L-Phase (230 V)
 - 2 Mains connection N-neutral conductor (230 V)
 - 3 CLOSE-button signal (230 V)
 - 4 OPEN-button signal (230 V)

Parallel connection (optional)

- All VOLETRONIC sliding shutter drives must have been taught in separately before they are connected in parallel!
- A maximum of 15 drives may be connected in parallel
- ▶ First teach in the first drive and check its functionality.
- ▶ Teach in each additional drive separately and check them for functionality
- ▶ Switch the taught-in drives in parallel as shown in the connection diagram.

Commissioning

NOTE

- The correct installation of the sliding shutter drive may be carried out only by authorised specialist personnel; it is only then that the entire functionality can be guaranteed.

Initial commissioning can be carried out once the motor has been correctly installed in the sliding shutter system.

- ▶ Connect the 5-wire Hirschmann coupling to your serial push-button and your electrical circuit!
- ▶ Check the running direction

*If the running direction is correctly set, then the LED display on the motor will light up **green** during $\leftarrow\rightarrow$ ascent and **red** during $\rightarrow\leftarrow$ descent. If this is not the case, then the running direction must be changed (see  chapter "Setting the running direction," page 14).*

SERIAL PUSH-BUTTON

- In order to avoid an unwanted change of parameters, the time (max. 2 sec.) between the individual programming steps must be observed.
- The *signal tones* must have gone out before the next programming step.
- Always check the running direction after a change of parameters. It is displayed accordingly through the LED on the drive housing with **green** for $\leftarrow\rightarrow$ ascent, **red** for $\rightarrow\leftarrow$ descent and **yellow** during the learning run.

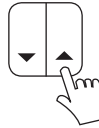

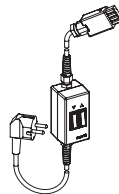

MOTOR SETTING & INSPECTION UNIT

- As an optional alternative to the serial push-button, the motor *can* also be tuned through the "motor setting & inspection unit V3, 5-wire", art. no. 881057.
- If no connector is available at the time of the installation, then the motor setting & inspection unit *must* be used.



Setting the running direction

- 1 Press and hold down the  OPEN button and the  CLOSE button together and simultaneously (approx. 3 sec.), until a brief signal tone is heard and then goes out.
 - 2 Release the buttons only briefly, then, within a maximum of 2 seconds, press and hold them down simultaneously again until the following 2 signal tones go out.
 - 3 Release the buttons briefly again and then repeat the procedure once more.
 - 4 However, after the sounding of the 3 signal tones, do not release the buttons until a longer signal tone is heard and goes out. The running direction is thus changed.
- Check the running direction through LED check.

1

- ▶ Hold OPEN + CLOSE button pressed down for approximately 3 sec.
- ▷ 1 signal tone

2



- ▶ Release OPEN + CLOSE button
- ▶ Press and hold OPEN + CLOSE button down once more within 2 sec. for approx. 3 sec.
- ▷ 2 signal tones

3

- ▶ Release OPEN + CLOSE button
- ▶ Press and hold OPEN + CLOSE button down once more within 2 sec. for approx. 3 sec.
- ▷ 3 signal tones

4

- ▶ Continue to hold OPEN + CLOSE button pressed down until
- ▷ Long signal tone
- ▷ *the running direction is changed*

- ▶ Check the running direction
- If the running direction is correct, the LED will show:
- ▷ **green** at  ASCENT
- ▷ **red** at  DESCENT

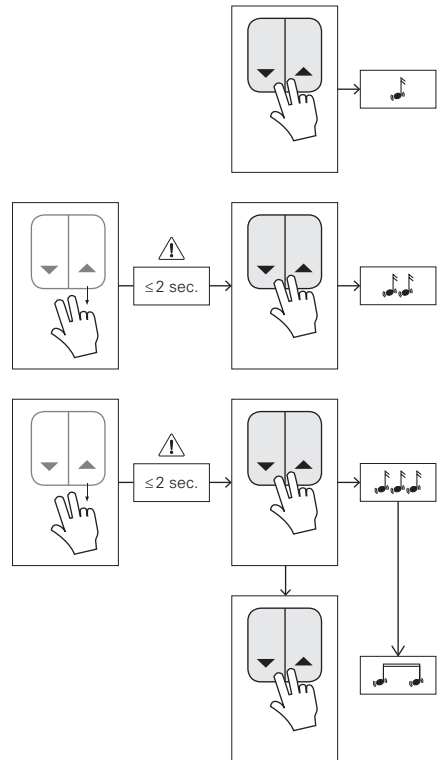





Executing a learning run

NOTES

Systems with double bars (a sash that is not connected with the drive cable)



The double bars must be manually taught during the learning run:

- ▶ Move sashes into the Open end position
- ▶ As soon as the powered sash moves the double bar, the  OPEN and the  CLOSE button must be actuated briefly and simultaneously. A signal tone confirms the programming.
- ▶ This procedure must be repeated in the case of systems with several double bars (max. 4). Each manual actuation of an additional double bar is acknowledged with an additional signal tone.

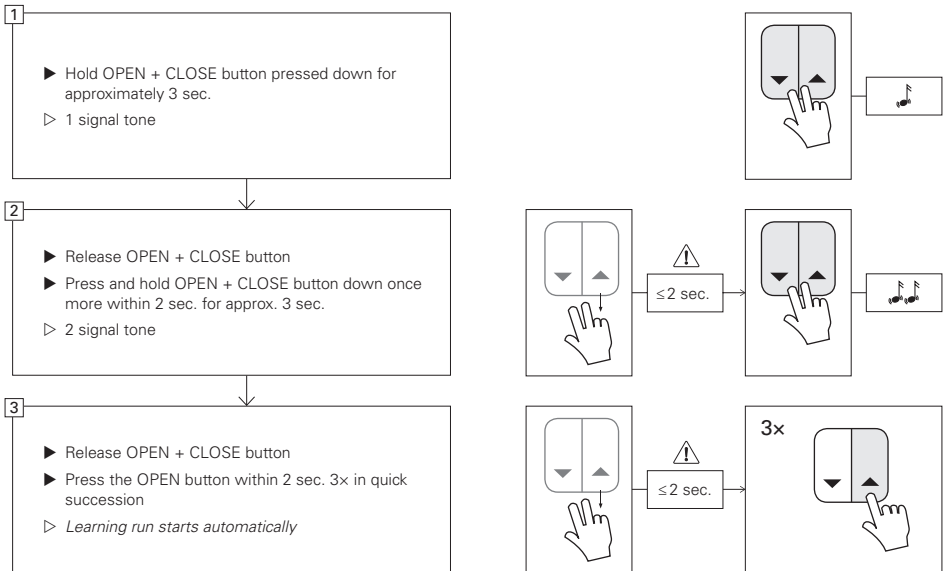
- 1 Press and hold down the  OPEN button and the  CLOSE button together and simultaneously (approx. 3 sec.), until a brief signal tone is heard and then goes out.
 - 2 Release the buttons only briefly, then press and hold them down together again once more until the following 2 signal tones go out.
 - 3 After the second signal tone, immediately press the  OPEN button 3x in quick succession. The learning run starts automatically.
- ☑ LED monitoring: When the learning run is correct, the LED on the drive lights up **yellow** and ends with a twotime signal tone.



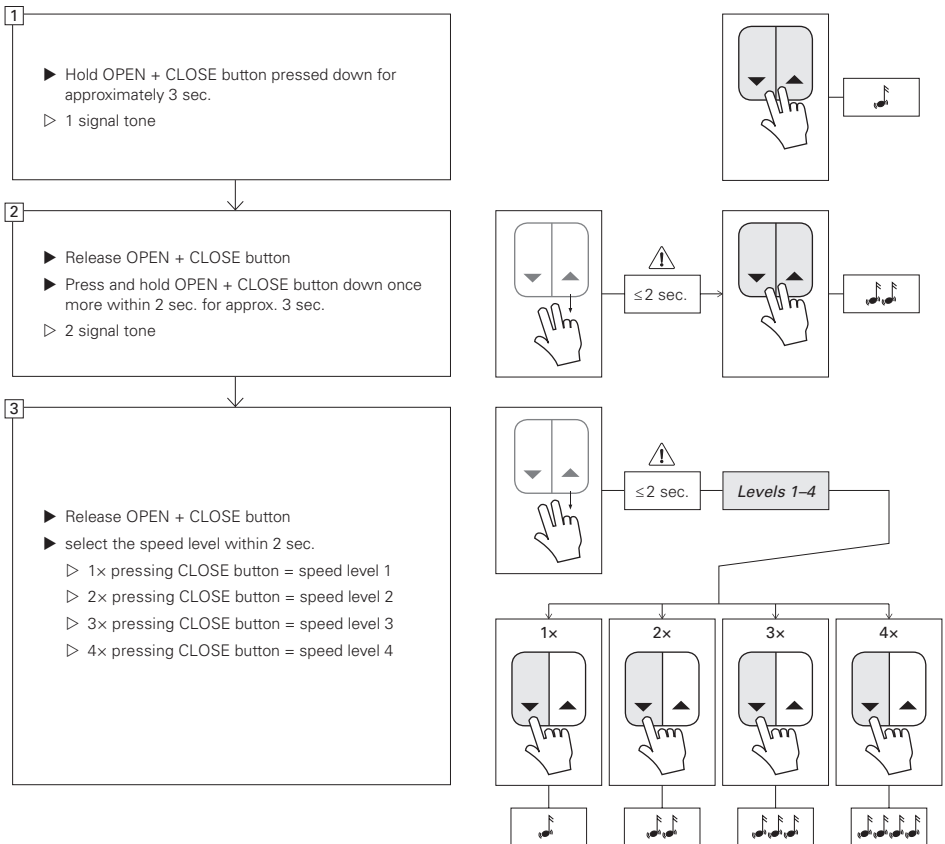

Setting the speed

- 1 Press and hold down the  OPEN button and the  CLOSE button together and simultaneously (approx. 3 sec.), until a brief signal tone is heard and then goes out.
- 2 Release the buttons only briefly, then press and hold them down together again once more until the following 2 signal tones go out.
- 3 Release the buttons and then select the desired speed level (max. 4 levels) by repeatedly and briefly pressing the  CLOSE button. The respective speed level is displayed accordingly by the number of signal tones.





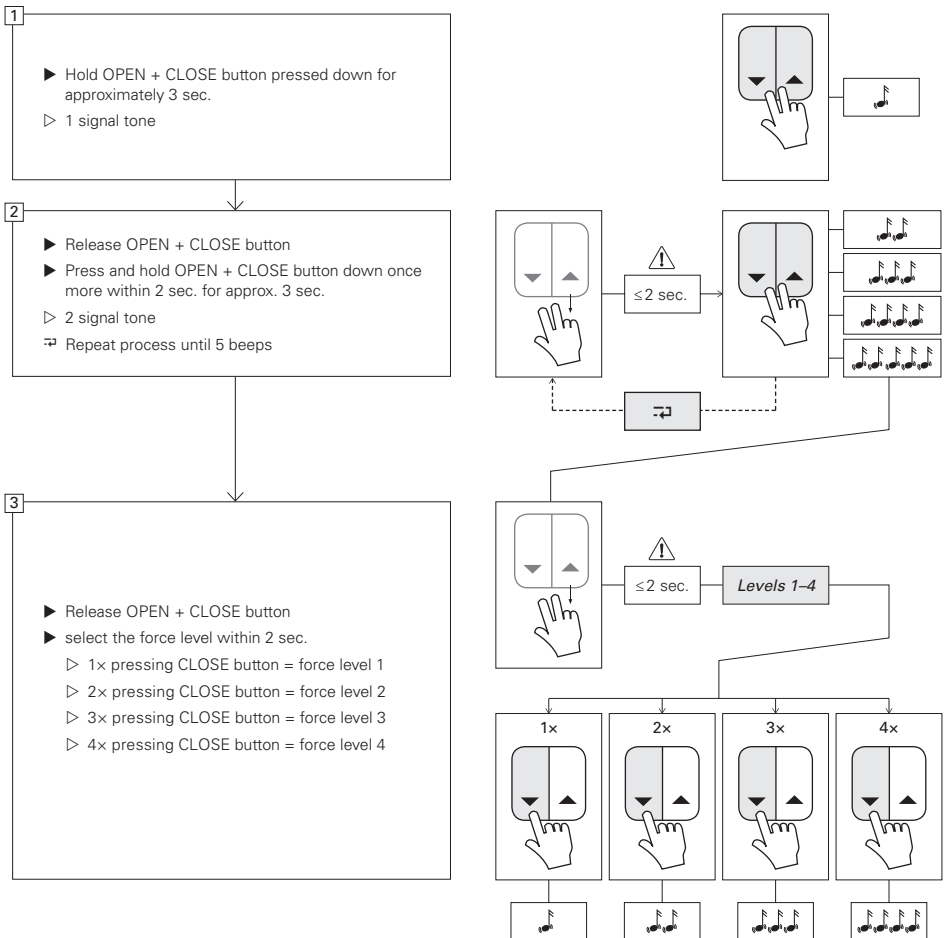

Setting the force

- 1 Press and hold down the  OPEN button and the  CLOSE button together and simultaneously (approx. 3 sec.), until a brief signal tone is heard and then goes out.
- 2 Release the buttons only briefly, then press and hold them down together again once more until the following 2 signal tones go out. Repeat this procedure until you hear 5 signal tones.
- 3 Release the buttons and then select the desired force level (max. 4 levels) by repeatedly and briefly pressing the  CLOSE button. The respective force level is displayed accordingly by the number of signal tones. The factory setting is force level 2.



Impulse/dead man mode

- 1 Press and hold down the  OPEN button and the  CLOSE button together and simultaneously (approx. 3 sec.), until a brief signal tone is heard and then goes out.
- 2 Release the buttons only briefly, then press and hold them down together again once more until the following 2 signal tones go out.
- 3 Repeat this procedure until 3 signal tones are heard and go out.
- ☑ Repeat this procedure until 4 signal tones are heard and go out. However, after the fourth signal tone sounds, continue to hold the  OPEN button and the  CLOSE button pressed down until a brief signal tone confirms *impulse mode*, or a long signal tone confirms *dead man mode*.

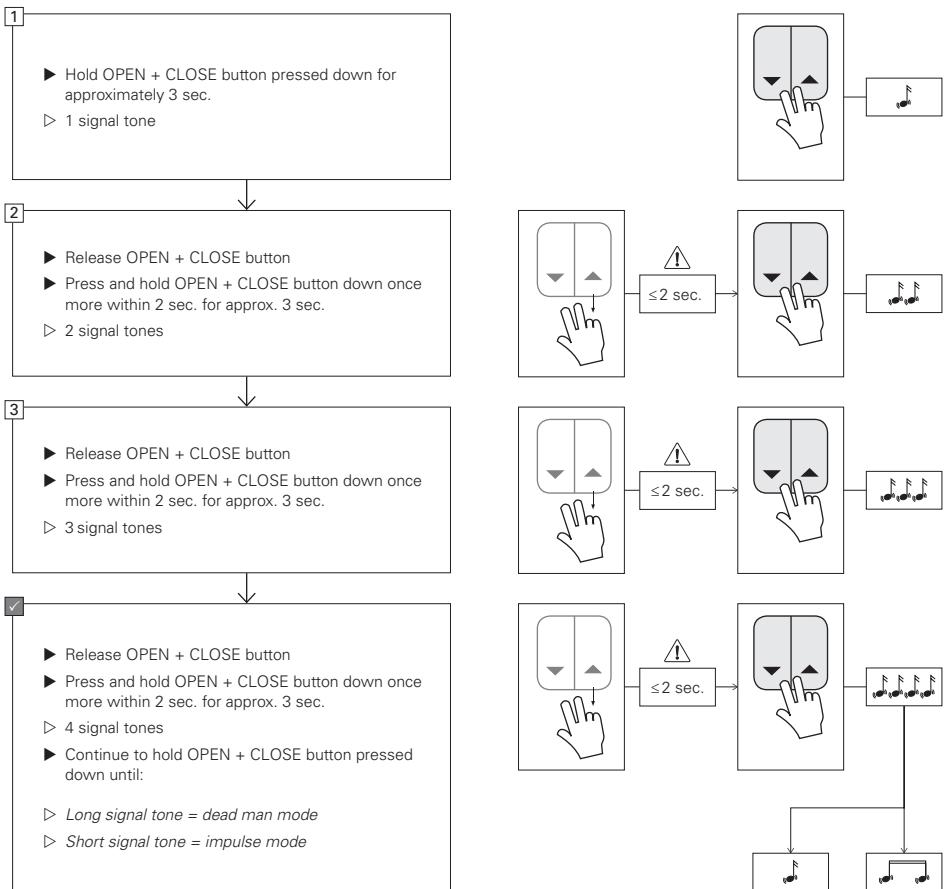

B | VOLETRONIC 230 V | wireless remote control

Product description

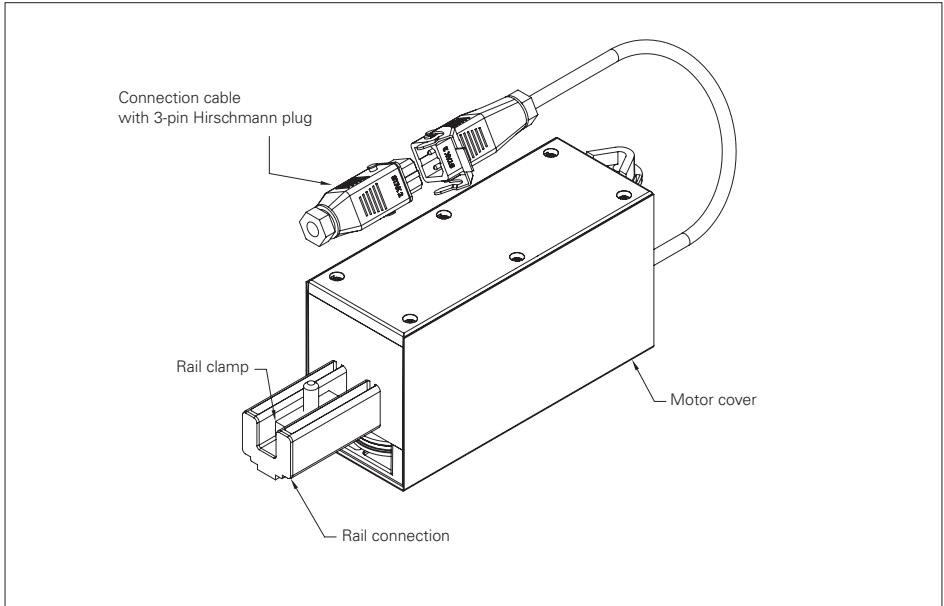

Technical data

<i>Power supply</i>	85 VAC–265 VAC, 50/60 Hz	<i>Torque duration</i>	0.42 Nm 100% ED
<i>Standby</i>	< 0,5W	<i>Short-term permissible torque</i>	0.9 Nm < 1 sec
<i>Max. motor power</i>	approx. 30W	<i>Force detection</i>	Internal speed measuring system (speedometer)
<i>IP type of protection</i>	IP54	<i>Motor gearbox</i>	Transmission ratio 111: 1
<i>Temperature range</i>	–20° C to +60° C	<i>Connection cable</i>	Hirschmann plug, 3-pin
<i>Timeout duration</i>		<i>Radio frequency</i>	868 MHz RC-01
Teach-in run	approx. 420 sec	<i>Radio range approx.</i>	100 m (free field)
Normal operation	approx. 240 sec		
<i>Speeds</i>			
Level 1	approx. 2.5 cm/sec		
Level 2	approx. 3.5 cm/sec		
Level 3	approx. 4.5 cm/sec		
Level 4	approx. 5.5 cm/sec		



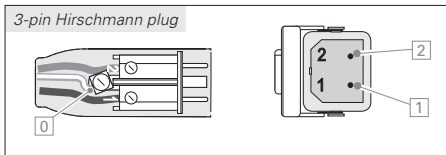
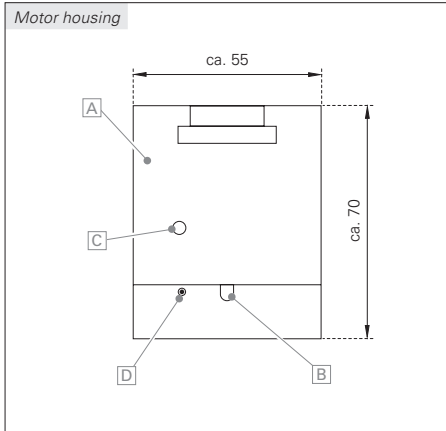

Connection





The VOLETRONIC sliding shutter drive with wireless remote control is a drive with integrated control for the actuation of sliding shutters.

- Configurable running speed
- Electronic locking in end position
- Programming of the pick-up position of double bars and acceleration or delay of the running speed at the beginning, the end and in the pick-up range.
- Creep travel upon reaching the start and end position

Motor

-  Motor cover
-  230 V mains connection with Hirschmann coupling. The motor is equipped with a 3-pin connection cable with Hirschmann coupling approx. 0.5 m.
-  Monitoring LED on the side of the motor housing (green | yellow | red) used for example for checking the running direction
-  Antenne 868 MHz

3-pin Hirschmann-plug

-  Earth – protective conductor (green/yellow)
 -  Mains connection L – Phase (230 V)
 -  Mains connection N – Neutral conductor (230 V)
- Hirschmann plug (must be connected to the electrical circuit by an electrician)

Commissioning

NOTES

- The correct installation of the sliding shutter drive may be carried out only by authorised specialist personnel; it is only then that the entire functionality can be guaranteed.

WIRELESS REMOTE CONTROL

- ▶ In order to avoid an unwanted change of parameters, the time (max. 2 sec.) between the individual programming steps must be observed.
- ▶ The signal tones must have gone out before the next programming step.
- ▶ Always check the running direction after a change of parameters! It is displayed accordingly through the LED on the drive housing with **green** for \leftarrow ascent, **red** for \rightarrow descent and **yellow** during the learning run.

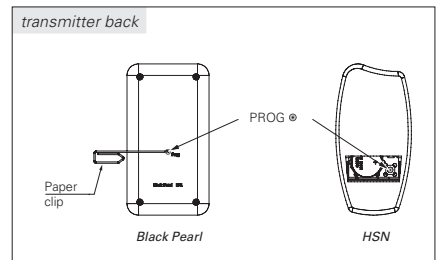
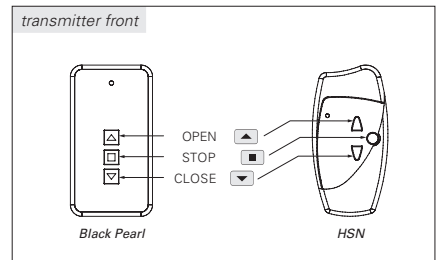



Teaching master transmitter

NOTES

- The teaching of the master transmitter in the motor must take place at a short distance. All further settings can be undertaken from a greater distance.
- Parameter modifications can be carried out only with the master transmitter. The parameter modifications are transferred to the additionally taught transmitters as required.
- Every new, non-programmed or cleared transmitter can be used as a master transmitter. The transmitter taught as a master transmitter emits a signal tone when the Prog-button is actuated.

IMPORTANT: If several motors are supplied with current via a fuse, all motors affected by the interruption to the power supply will switch to PROGRAMMING MODE. Please note this information to ensure that the master transmitter is only taught in on the desired motor(s)!

▶ Disconnect the other motors if necessary!

- 1 Interrupt electricity supply for approx. 10 sec. Hold the transmitter to be taught at a distance of approx. 1 m in front of the drive. Press the PROG button with the paper clip and hold it down. While doing so, move with the transmitter in the direction of the drive until a signal tone sounds and goes out.
 - 2 Now release the PROG button and press the  OPEN button on the transmitter within approx. 2 sec. and hold it down until a signal tone confirms the correctness of the programming. The new transmitter is now programmed as *master transmitter*.
- ☑ Checking the running direction (changing it if necessary), see  chapter "Checking/Changing the running direction," page 24.

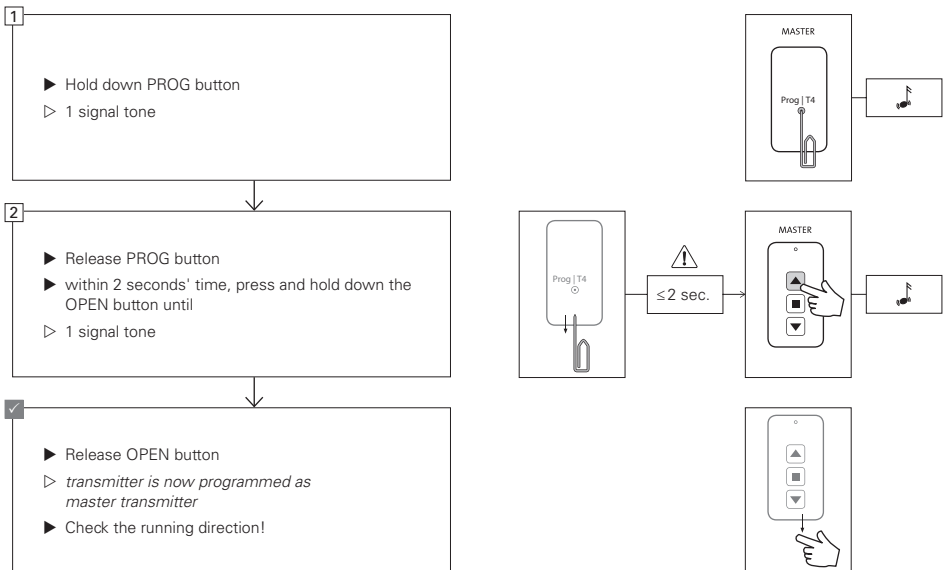

Checking/Changing the running direction

- 1 If the running direction is correctly set, then the LED display on the drive will light up **green** during \leftarrow ascent and **red** during \rightarrow descent. If this is not the case: Continue to hold the PROG button pressed down until the following signal tone has gone out.
- 2 Release the PROG button and, within approx. 2 sec., briefly press the OPEN button once. The uniform signal tones that sound for around 16 sec. confirm the learning mode.
- 3 During the learning mode, press the CLOSE button until the subsequent signal tone goes out.
- ✓ Check the running direction! If the running direction is not set correctly, repeat steps 1+2 and then carry out step 3 during the learning mode.
- ⌚ During the learning mode, press the OPEN button until the subsequent signal tone goes out.

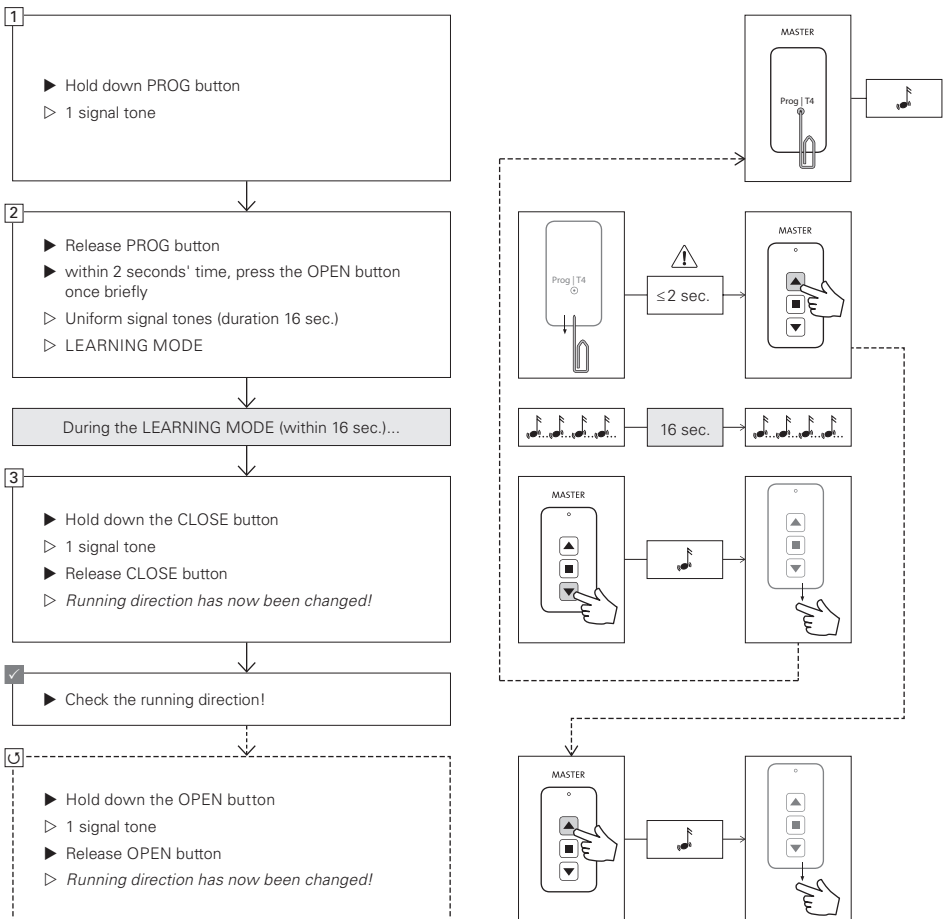







Performing a learning run

NOTES

Systems with double bars (a sash that is not connected with the drive cable)

The double bars must be manually taught during the learning run:

- ▶ Move sashes into the Open end position
- ▶ As soon as the powered sash moves the double bar, the  OPEN and the  CLOSE button must be actuated briefly and simultaneously. A signal tone confirms the programming.
- ▶ This procedure must be repeated in the case of systems with several double bars (max. 4).

- 1 Continue to hold the PROG  button pressed down until the subsequent signal tone has gone out
 - 2 Now release the PROG  button and, within 2 sec., hold down the  OPEN and the  CLOSE button on the master transmitter (approx. 5 sec.), until the subsequent signal tone has gone out.
 - 3 Immediately, within 2 sec., hold the  OPEN button pressed down until the learning run starts.
- LED monitoring: When the learning run is correct, the LED on the drive lights up **yellow** and ends with a twotime signal tone.

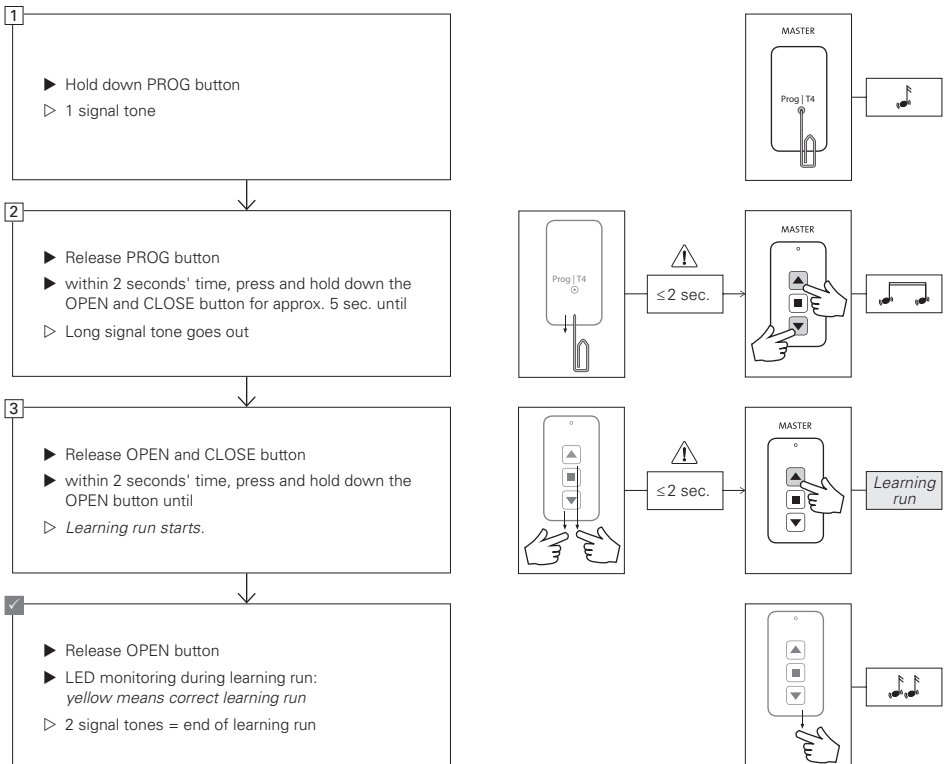

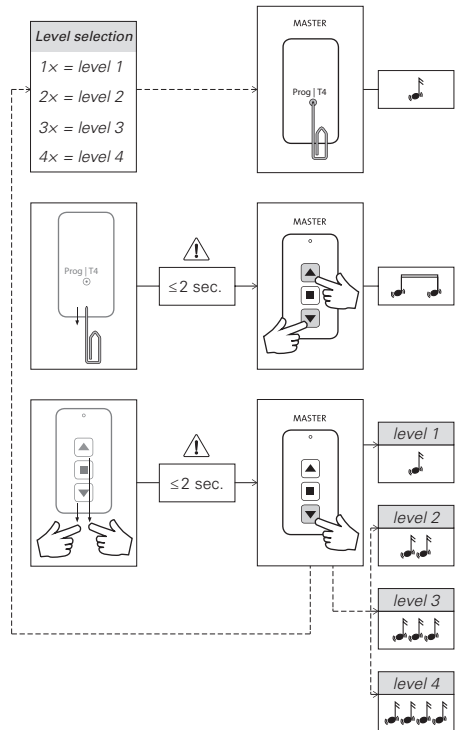
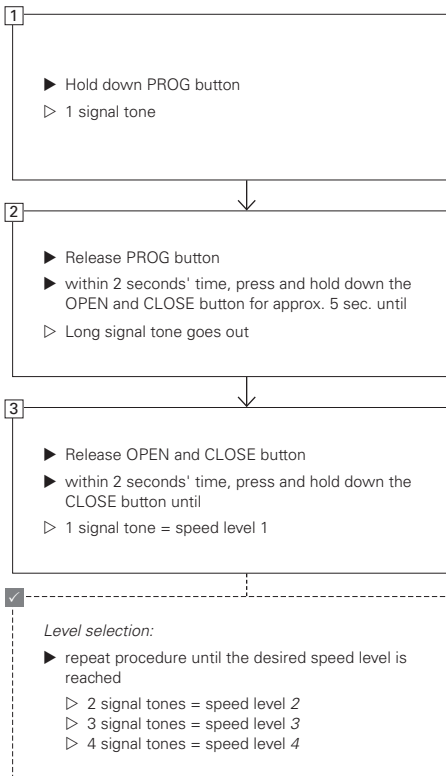

Setting the speed

- 1 Continue to hold the PROG button pressed down until the subsequent signal tone has gone out.
 - 2 Now release the PROG button and, within 2 sec., hold down the OPEN and the CLOSE button on the master transmitter until the continuous signal tone has gone out
 - 3 Immediately, within 2 sec., keep the CLOSE button pressed down until a signal tone acknowledges the speed level (1 signal tone = 1st level up to 4 signal tones = 4th level).
- ✓ The procedure must be repeated respectively often until the desired speed level is reached.



Setting the force

- 1 Continue to hold the PROG button pressed down until the subsequent signal tone has gone out.
 - 2 Now release the PROG button and, within 2 sec., hold down the  OPEN and the  CLOSE button on the master transmitter until the continuous signal tone has gone out
 - 3 Immediately, within 2 sec., keep the  STOP button pressed down until a signal tone acknowledges the force level (1 signal tone = 1st level up to 4 signal tones = 4th level).
- ✓ The procedure must be repeated respectively often until the desired force level is reached.

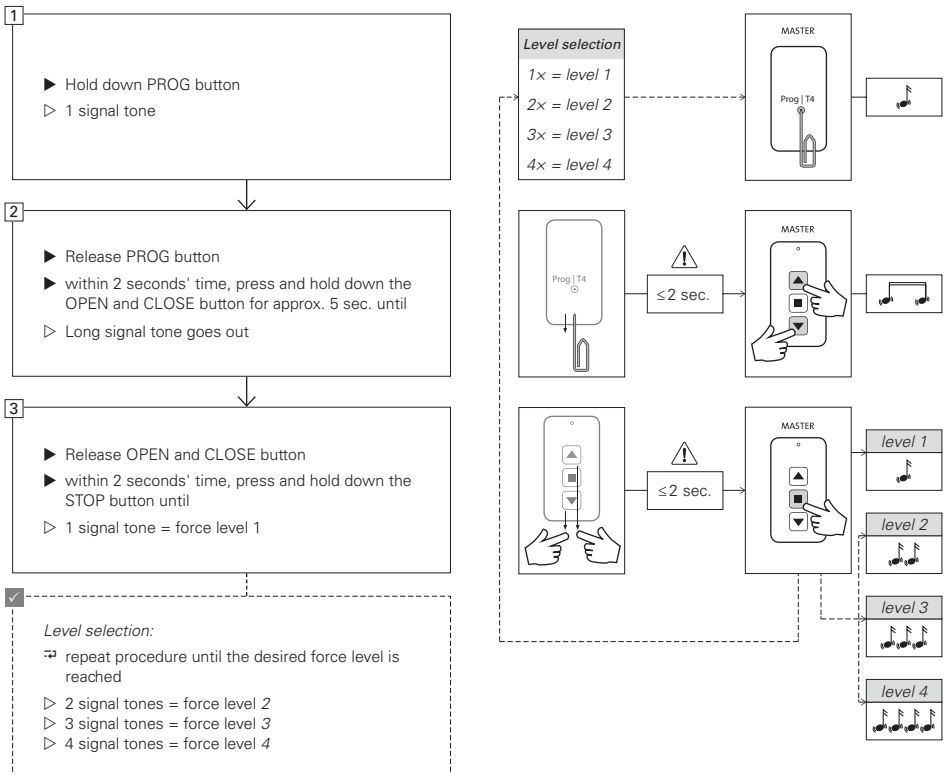

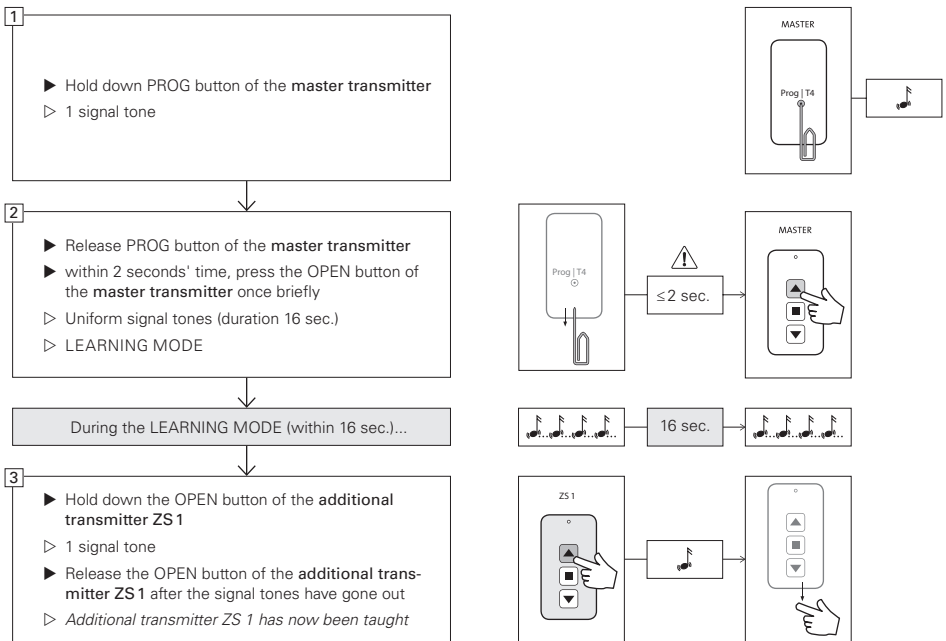

Teaching an additional transmitter

- 1 Continue to hold the PROG button pressed down until the subsequent signal tone has gone out
- 2 Release the PROG button and, within approx. 2 sec., briefly press the OPEN button on the master transmitter once. The uniform signal tones that sound for around 16 sec. confirm the learning mode.
- 3 During this time, press the OPEN button of the additional transmitter until the signal tones have gone out.



Clearing of an additionally taught transmitter

- 1 Continue to hold the PROG button pressed down until the subsequent signal tone has gone out
- 2 Now release the PROG button and, within approx. 2 sec., actuate the  CLOSE button on the master transmitter. The rapid signal tones, that continue for approx. 16 sec., confirm the clearing mode.
- 3 During the clearing mode, press the  CLOSE button of the additional transmitter until the signal tones have gone out.

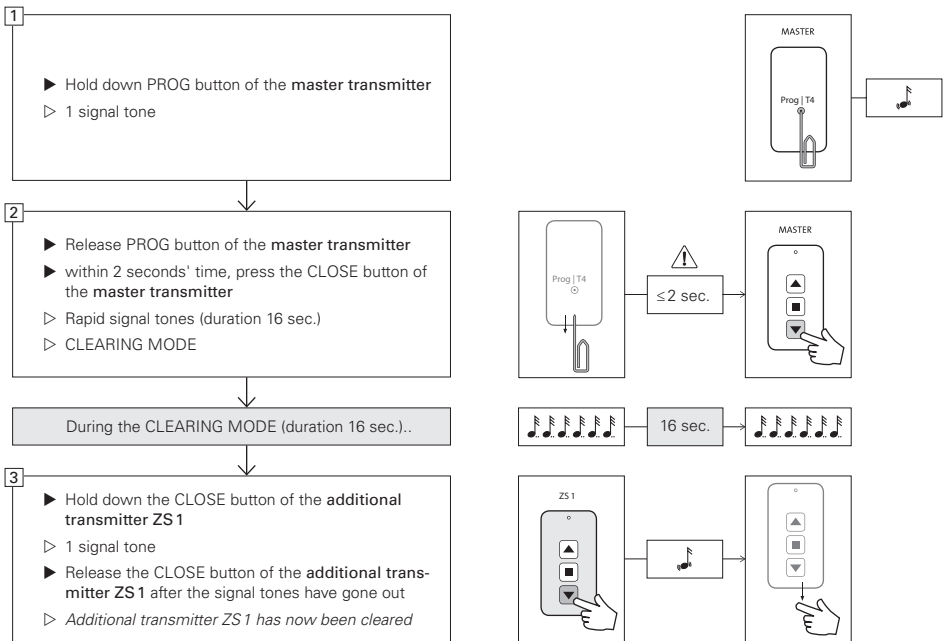

Global clearing of all additionally taught transmitters

- 1 Continue to hold the PROG button pressed down until the subsequent signal tone has gone out
- 2 Now release the PROG button and, within approx. 2 sec., actuate the  CLOSE button on the master transmitter. The rapid signal tones, that continue for approx. 16 sec., confirm the clearing mode.
- 3 During the clearing mode, hold the PROG button of the master transmitter pressed down until the following signal tone has gone out.

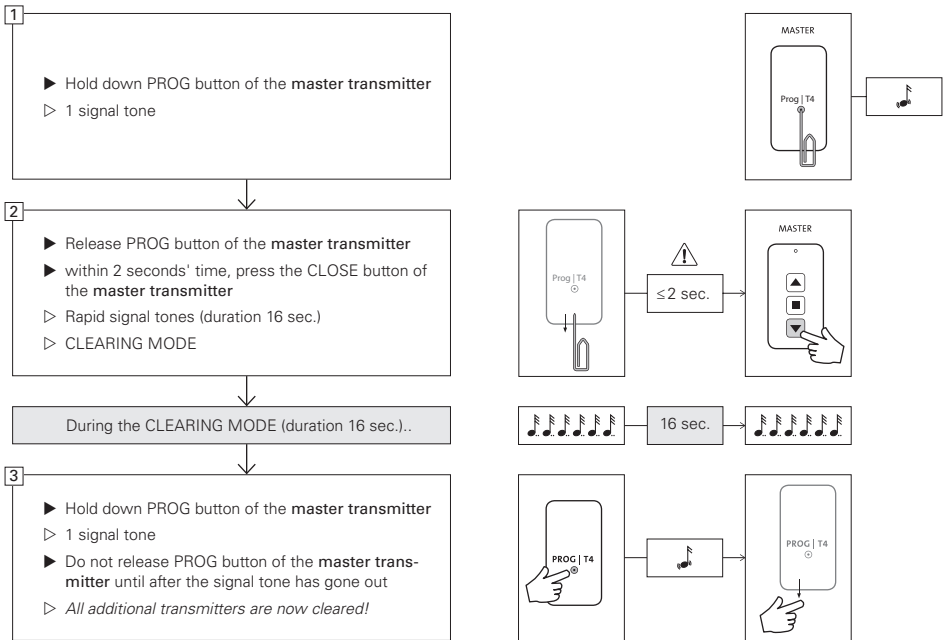

Group control

Application example 1

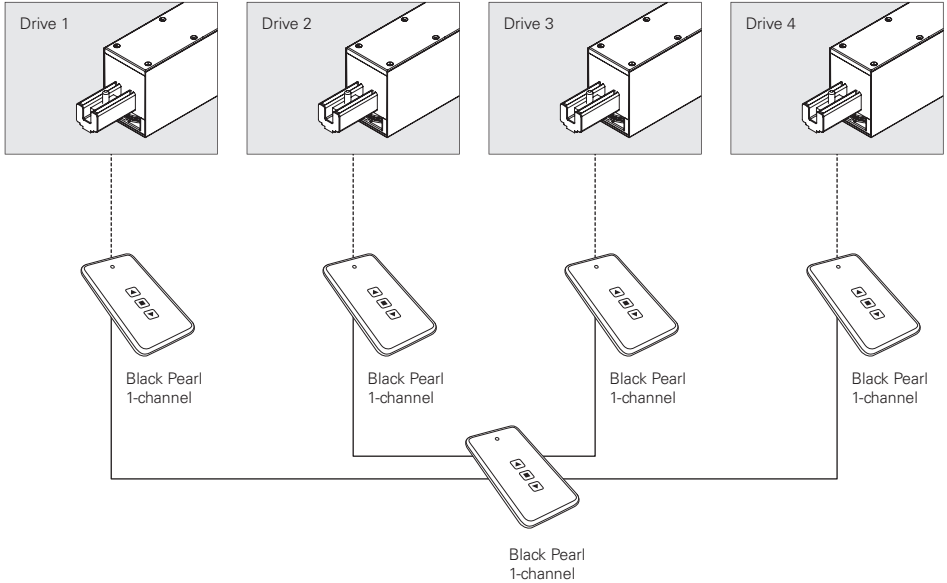



- ▶ Every drive with wireless actuation is assigned its own 1-channel wireless hand-held transmitter as master transmitter.

Important: All settings can be made only with the master transmitter!

- ▶ In addition, another 1-channel wireless hand-held transmitter is taught as an additional transmitter for each drive (see programming instructions  chapter "Teaching an additional transmitter", page 28).
- ▷ All of the drives can thus be actuated simultaneously with the additional wireless hand-held transmitter.

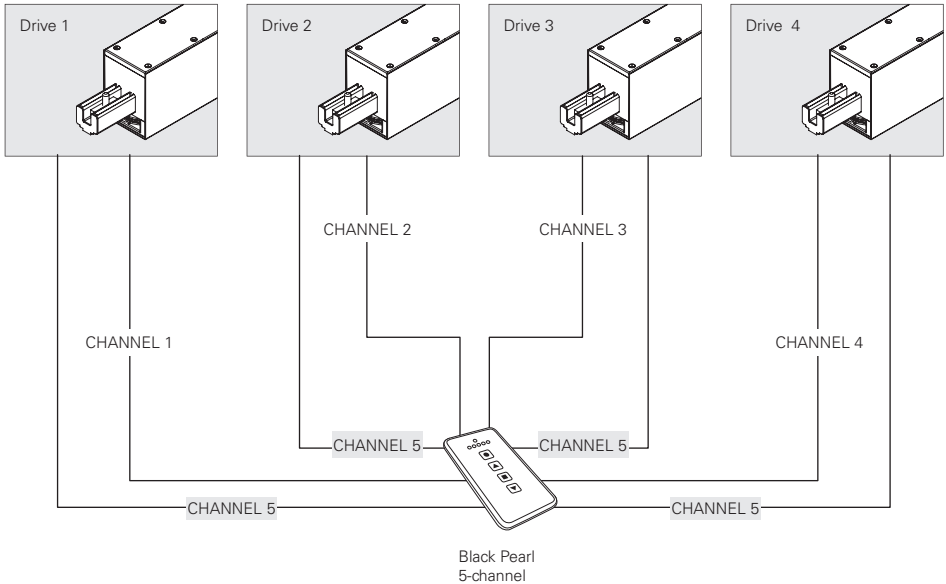
Application example 2



- ▶ Every drive with wireless actuation has a wireless channel reserved for its use on the multi-channel wireless hand-held transmitter. This channel assumes the master function of the drive. The individual channels are displays through different illuminations of the LEDs on the multi-channel hand-held transmitter.
- ▶ In this example, Channel 1 has been selected for Drive 1, Channel 2 for Drive 2, Channel 3 for Drive 3 and Channel 4 for Drive 4. After all of the drives have been taught, Channel 5 can now be taught as *additional transmitter* for all of the drives.
- ▶ To accomplish this, proceed as follows: Select Channel 1 on the multi-channel handheld transmitter and activate the teaching an additional transmitter function (see  chapter "Teaching an additional transmitter", page 28).
- ▶ While the yellow LED on the drive is flashing, select Channel 5 and teach the transmitter by actuating the OPEN button. Drive 1 in Channel 1 and Channel 5 is thus taught. Afterwards, teach Drives 2, 3 and 4 the same way. Thus all drives can be actuated simultaneously through Channel 5.

C VOLETRONIC Solar 12 V | wireless remote control

Product description

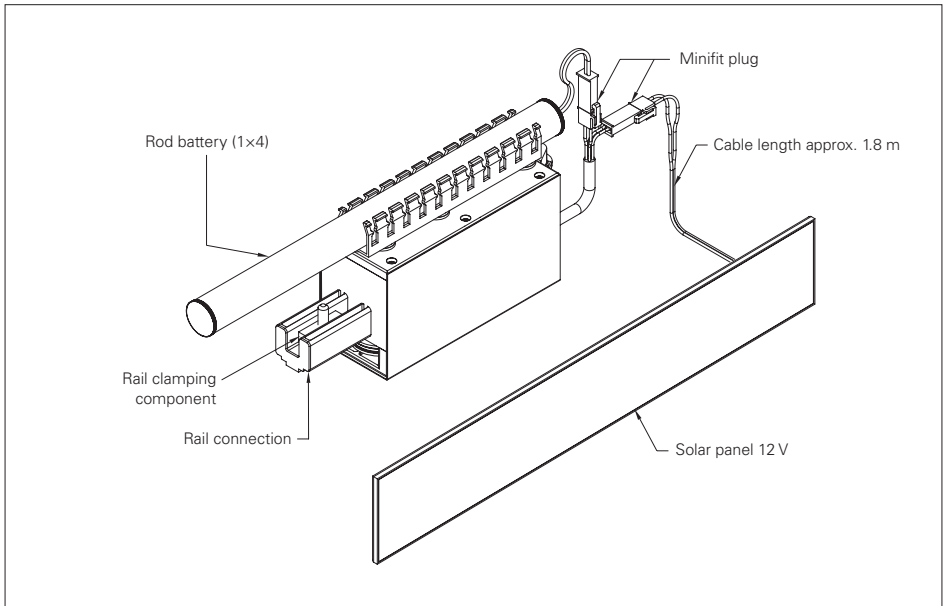

Technical data

<i>Power supply</i>	12 V / DC solar	<i>Torque duration</i>	0.42 Nm 100% ED
<i>Standby</i>	< 0,5W	<i>Short-term permissible torque</i>	0.9 Nm < 1 sec
<i>Max. motor power</i>	approx. 30W	<i>Force detection</i>	Internal speed measuring system (speedometer)
<i>IP type of protection</i>	IP54	<i>Motor gearbox</i>	Transmission ratio 111: 1
<i>Temperature range</i>	-20° C to +60° C	<i>Battery</i>	LiFePO4 battery 12.8 V, 1250 mAh
<i>Timeout duration</i>		<i>Power reserve</i>	approx. 100–150 runs
<i>Teach-in run</i>	approx. 420 sec	<i>Radio frequency</i>	868 MHz RC-01
<i>Normal operation</i>	approx. 240 sec	<i>Radio range approx.</i>	100 m (free field)
<i>Speeds</i>			
Level 1	approx. 2.5 cm/sec		
Level 2	approx. 3.5 cm/sec		
Level 3	approx. 4.5 cm/sec		
Level 4	approx. 5.5 cm/sec		

Connection

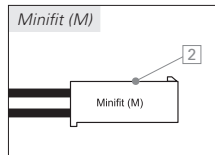
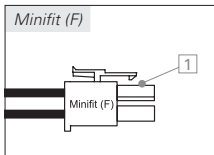
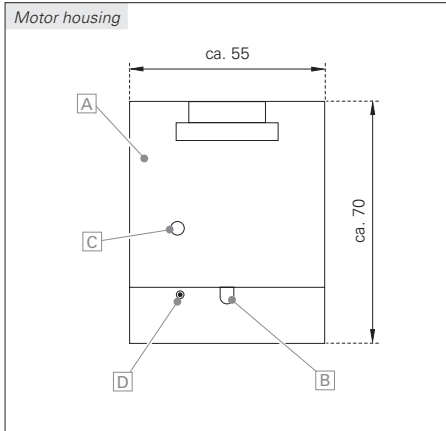

Motor

- A Motor cover
 - B Minifit cable outlet
 - C Monitoring LED on the side of the motor housing (green | yellow | red) used for example for checking the direction of travel
 - D Antenne 868 MHz
- 1 Motor connection cable with minifit connector (F) for connection to the battery pack
 - 2 Motor connection cable with minifit connector (M) for connection to the solar panel, cable length approx. 1.8 m.

The EHRET VOLETRONIC Solar sliding shutter drive is a drive with integrated control for the actuation of sliding shutters.

- Configurable running speed
- Programming of the pick-up position of double bars and acceleration or delay of the running speed at the beginning, the end and in the carriage range.
- Creep travel upon reaching the beginning and end positions
- The motor is equipped with two connection cables with minifit plugs for the connection with a solar panel (12 V) and a rechargeable battery (1×4 in a Plexiglas tube).

Connection sequence

- ▶ Connect the battery **first**
- ▶ **Then** connect the solar panel

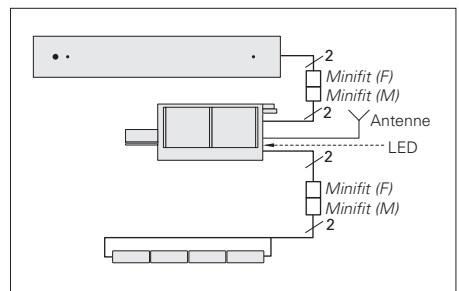

Attach solar panel on the cover

⚠ CAUTION

- Because of the mounting holes in the cover, no later modification is possible!
- When installing the solar panel, take care to ensure that the cables and minifit plugs are not exposed to direct sunlight!

NOTES

Follow all instructions so that the corresponding power is generated, the solar concept energy balance does not fall below zero and the battery does not drain. This could otherwise lead to loss of function, but is nonetheless not a technical defect.

The solar panel is able to generate electricity only when sunlight falls on the visible face of the panel.

- Care must be taken to ensure the line of sight from the solar panel to the sky.
- Take care to ensure that the solar panel is not shaded by trees standing in front of it, overhanging roofs or parked vehicles (lorries).

Depending on the location, environmental and natural factors, it is advisable to check the solar panel regularly at one's own discretion and to initiate appropriate measures as necessary.

- Protect the solar panel against soiling and environmental factors (use only water and a soft cloth to clean!).
- Protect the solar panel against damage, as it is essentially comprised of only a pane of glass. External impacts and mechanical stresses may lead to the formation of cracks (microfissures), which may then lead to partial or total destruction of the panel.

Correct installation:



Incorrect installation:



Electrical data	overcast	sunny
With solar radiation	10 mW/cm ²	100 mW/cm ²
No-load voltage	20 V	24 V
Voltage at nominal load	15 V	18 V
Current at nominal load	23 mA	225 mA
Nominal power	0,35 W	4,0 W

- ▶ The panel is attached as standard near the drive with an edge clearance of 100 mm to the edge of the cover.

The solar panel cannot be fastened as standard with ceiling installation (see Notes).

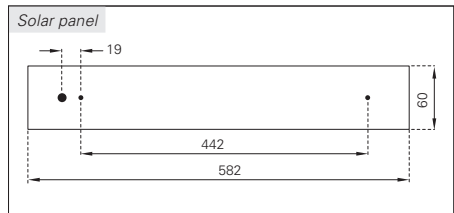

Attaching the rechargeable battery

CAUTION

The rechargeable batteries are a delicate structural component that may not be damaged. Take this fact into account for handling and during installation.

NOTES

Follow all instructions so that the corresponding power is generated, the solar concept energy balance does not fall below zero and the battery does not drain. This could otherwise lead to loss of function, but is nonetheless not a technical defect.

- Do not expose the rechargeable batteries to direct moisture or sunlight.
- Protect the rechargeable batteries against splashing water.

A short circuit between the +/- output lines will lead to immediate destruction. If, despite a warning signal from the drive, a rechargeable battery is operated at low battery voltage, there is a risk of a defect occurring as the result of total discharge.

- Care must be taken to ensure that none of the connection cables are pinched; otherwise there is a risk of short circuit and system failure.
- Rod battery and standard clamp are delivered unmounted.
- The battery must be installed inside the carrier housing.

Correct installation:



Incorrect installation:



- ▶ Standard installation: Clamp the battery in the standard clamp and fasten this to the motor housing with Klett pins

The battery cannot be fastened as standard with ceiling installation (see Caution).

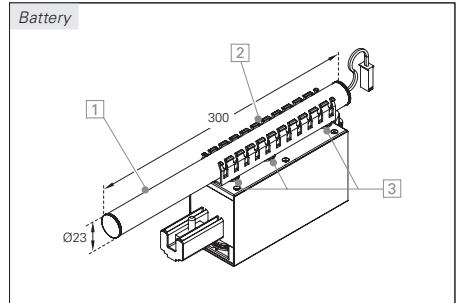

Changing the battery / disassembly

- ▶ Disconnect the battery from the motor
- ▶ Disconnect the solar panel from the motor
- ▶ Connect the new battery to the motor
- ▶ Connect the solar panel to the motor

Connecting the solar components

- ▶ Connect the battery first
- ▶ Then connect the solar panel

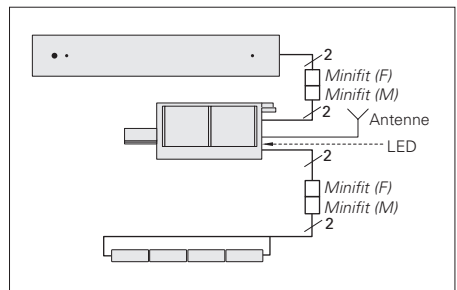

Commissioning

NOTES

- The correct installation of the slide shutter drive may be carried out only by authorised specialist personnel; only then can complete functionality be guaranteed.
- All cables and plug connections must be installed in such a way that they are protected against direct sunlight.

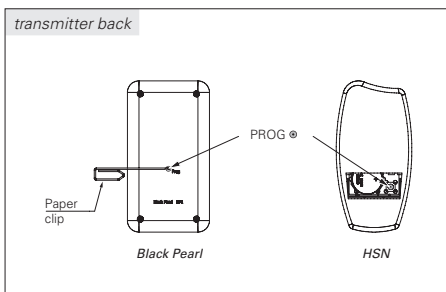
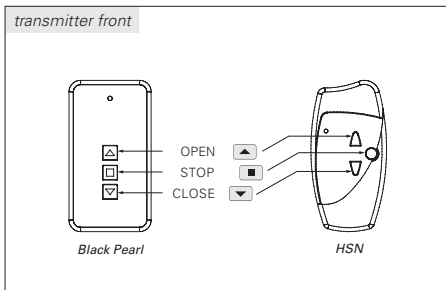

WIRELESS REMOTE CONTROL

- ▶ In order to avoid an unwanted change of parameters, the time (max. 2 sec.) between the individual programming steps must be observed without fail.
- ▶ It is imperative that the *signal tones* have ceased before the next programming step.
- ▶ Always check the direction of travel after a change of parameters! It is displayed accordingly by the LEDs on the drive housing with **green** for \leftarrow upward travel, **red** for \rightarrow downward travel and **yellow** during the learning run.

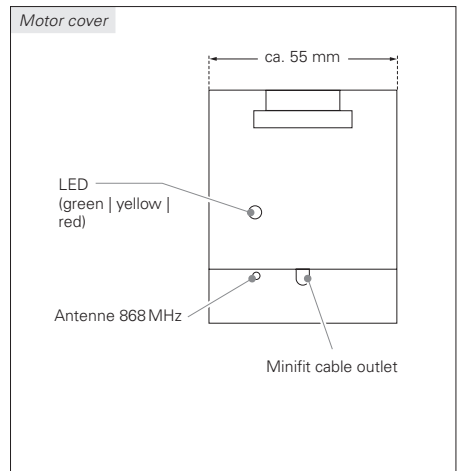

INITIAL COMMISSIONING

- Initial commissioning can be carried out once the motor has been correctly installed in the sliding shutter system. To accomplish this, the following 3 points must be carried out:

1. Teaching master transmitter S. 40



Teaching a master transmitter is a prerequisite for the commissioning of the VOLETRONIC Solar 12 V. Only with the master transmitter all of the settings can be made.

Except for the n-channel wireless hand-held transmitter, all wireless hand-held transmitters can be used as a master transmitter. With multi-channel wireless hand-held transmitters, any channel can be used as a master transmitter for a drive.

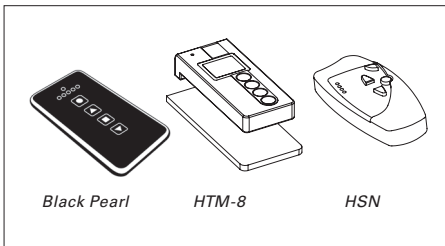
Important: Each drive must be taught on a separate wireless channel! The first transmitter to be taught becomes the master transmitter.



2. Monitoring solar panel and rechargeable battery

- ▶ Place the cover on the carrier profile and connect the solar panel with the motor.
- ▶ Press the  OPEN button and the  CLOSE button precisely simultaneously.

The LED on the drive will then display two illumination signals, one after the other:

*The 1st signal reports the **solar conditions**:*

yellow = Battery being charged, sufficient sun, panel connected

red = No sun, battery not being charged, panel is not connected correctly

*The 2nd signal reports the **battery status**:*

green = Battery fully charged

yellow = Battery almost discharged

red = Battery discharged, no further travel possible





3. Monitoring/modification of the direction of travel S. 41

If the direction of travel is correctly set, the LED on the drive will light up **green** during upward travel and **red** during downward travel.

If this is not the case, the direction of travel has to be changed, see  chapter "Monitoring/modification of the direction of travel", page 41).





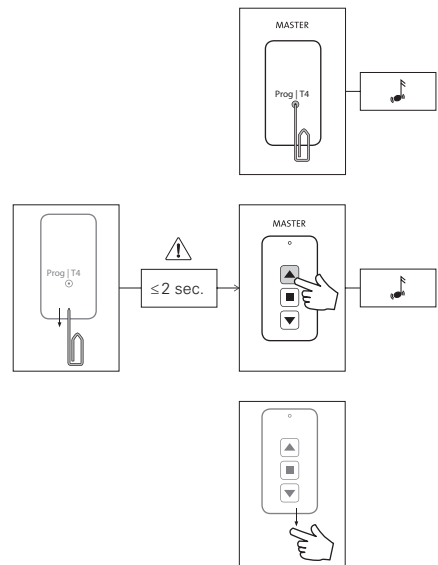
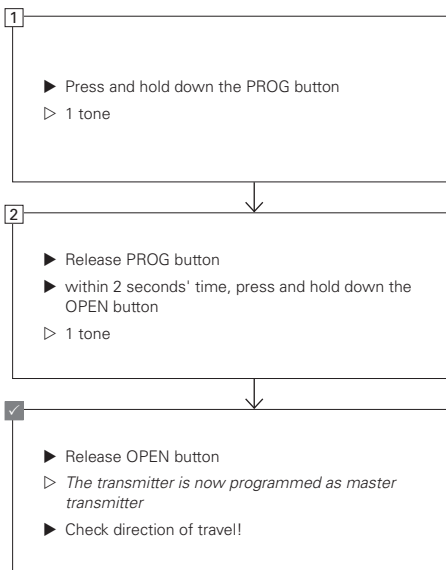

Teaching master transmitter

NOTES

- The teaching of the master transmitter in the motor must take place at a short distance. All further settings can be undertaken from a greater distance.
 - Parameter modifications can be carried out only with the master transmitter. The parameter modifications are transferred to the additionally taught transmitter as required.
 - Any new, non-programmed or cleared transmitter can be used as a master transmitter. The transmitter taught as a master transmitter emits a signal tone when the PROG button is actuated.
-
- ▶ In order to put the control in ready mode, the solar panel must be disconnected from the drive and the battery from the motor.
 - ▶ Wait approx. 10 seconds then re-connect the battery with the motor.
- 1 Hold the transmitter to be taught approx. 1 m away from the front of the drive. Press the  PROG button with the paper clip and hold it down. While doing so, move with the transmitter toward the drive until a signal tone sounds and ceases.
 - 2 Now release the  PROG button and, within 2 seconds' time, press the  OPEN button on the transmitter and hold it down until a signal tone confirms the correctness of the programming. The new transmitter is now programmed as master transmitter.
- ☑ Check direction of travel! (see  chapter "Monitoring/modification of the direction of travel!", page 41).



Monitoring/modification of the direction of travel

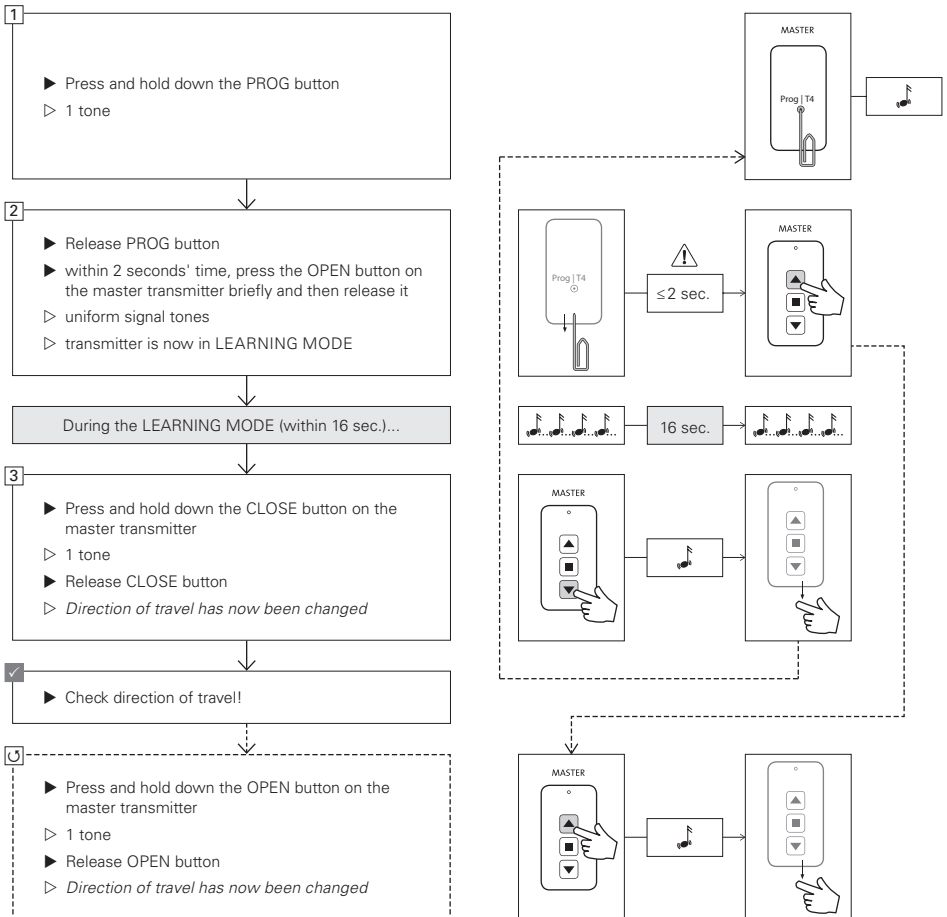

- 1 If the direction of travel is correctly set, the LED on the drive will light up **green** during  upward travel and **red** during  downward travel. If this is not the case: Press and hold the  PROG button down until the subsequent signal tone ceases.
- 2 Now release the  PROG button and, within 2 seconds' time, press  OPEN button on the master transmitter briefly and then release it. The uniform signal tones that sound for around 16 sec. confirm learning mode.
- 3 While the system is in learning mode, press  CLOSE button until the subsequent signal tone ceases.
- ✓ Check the direction of travel! If the direction of travel is still not set correctly, repeat steps 1+2 and then carry out step 3.
- ⌚ While the system is in learning mode, press  OPEN button until the subsequent signal tone ceases.



Further settings

NOTES

The VOLETRONIC Solar 12 V sliding shutter drive with wireless remote control is operated and programmed in the same way as the VOLETRONIC 230 V sliding shutter drive with wireless remote control:

- ▶ Further configuration options for your wireless remote control, e.g. BlackPearl, can be found in chapter  „ VOLETRONIC 230 V | Wireless Remote Control“; pages 25 ff.

Performing a learning run.....	 S. 25
Setting the speed.....	 S. 26
Setting the force	 S. 27
Teaching an additional transmitter.....	 S. 28
Clearing of an additionally taught transmitter.....	 S. 29
Group control	 S. 31

Troubleshooting

Problem	Possible cause(s)	Solution(s)
Sashes not moving, cable slipping	Cable tension too low	▶ Increase cable tension
Spring hitting the motor or the return pulley	Spring is not in the right position	▶ Position the spring on the motor side (see □ 915 installation instructions for sliding shutters, □ p. 37)
Irregular sash movement (sometimes fast, sometimes slow)	Learning run not executed	▶ Execute a learning run (see □ p. 14)
Sash stops during learning run	Sash rubbing against guide	▶ Check that the travel path allows free movement
Sashes do not reduce speed when approaching the end point	Learning run not executed	▶ Execute a learning run (see □ p. 14)
Motor guide sash picks up the double bar with a jerk	Pick-up function has not been taught	▶ Teach pick-up position during learning run (see □ p. 14)
Motor is connected to power supply but is not working	Power supply is interrupted somewhere	▶ Check whether it is possible to move the sash by hand (the sash can only be moved by hand when there is no voltage present)
No teach signal (beep when both switches are actuated, 230 V variant only)	Speaker defective	▶ Execute the learning run using the LED on the motor (visual signal rather than acoustic)
Sashes only move when switch is held down	Dead man mode is still activated	▶ Switch to impulse mode (see □ p. 18)
Motor running in wrong direction	Wiring on counterpart for Hirschmann plug, supply line or building connection is the wrong way round	▶ Check direction of rotation via LED; change direction of rotation or wiring if necessary (see □ p. 41)
Remote control has been pressed several times but motor is not running	Battery in remote control is flat	▶ Replace battery
Solar drive no longer working	Rechargeable battery is defective	▶ Replace rechargeable battery

Detecting radio problems

- Provided that there is no interference from external radio, the system must remain mostly in standby mode. Power consumption: approx. 140–160 μ A.
- The system's receiver is active if it detects radio signals (ideally only when the transmitter is activated). Power consumption: 7–9 mA. When the motor is running, the power can increase up to several hundred mA.
- **Important!** After commissioning, the system is in teach-in mode for 1 minute or until it receives the first radio signals. The receiver is activated. In the first minute, the power consumption is 7–9 mA.

EHRET GmbH

Aluminium Shutters

Bahnhofstrasse 14 - 18

D- 77972 Mahlberg

Tel. + 49(0) 78 22/439-0

Fax + 49(0) 78 22/439- 116

www.ehret.com