

E-motion

Bracket drive for window shutters



Installation and operating instructions

INSTALLATION
SPECIALIST PERSONNEL
Valid from 07.2018

E 636.4

Notes

These installation instructions describe how to commission the EHRET E-motion bracket drive.

Carefully read through these installation and operating instructions prior to commissioning. Observe the specified process steps and take into account the notes and recommendations given. Knowledge of and technically impeccable implementation of the given safety notes and warnings are prerequisites for safe and proper operation of the EHRET E-motion bracket drive. Insufficient knowledge at the time of commissioning and utilisation lead to the loss of any liability claims against EHRET GmbH. Installation and/or operation in full or partial deviation from our installation and operating instructions will lead to the warranty for defects becoming void.

Installation of the shutters in accordance with the EHRET window shutter installation instructions is a prerequisite for the commissioning of the EHRET E-motion bracket drive.

These installation and operating instructions are addressed to qualified specialist personnel. Qualified specialist personnel are persons who are familiar with the transport, set-up, installation, commissioning and operation of the product and who have appropriate qualifications for their work. Specialist personnel must know and observe the relevant standards and/or guidelines.

These installation and operating instructions are a component part of the product and are therefore always to be retained until the product is disposed of.

These installation and operating instructions are to be passed along in the event of the sale of this product. This product complies with the general rules of technology. Safety-conscious behaviour is necessary for commissioning the product safely. For this reason, observe the following notes.

Should you not understand something in these installation and operating instructions unambiguously, do not fail to contact the specialist personnel at EHRET GmbH, 77972 Mahlberg (Germany).

Contents

Notes	2
Explanation of signs and symbols	4
Safety notes	4
Installation FAQs.	6
Electrical installation	6
Disposal	7
1 Product description	
Product properties.	8
Wiring diagram	9
Scope of delivery	10
2 Installation instructions	
Marking the drill holes	13
Drilling the wall	14
Sealing the drive housing	14
Inserting the bracket drive.	15
Fit the chemical dowels	17
Fitting the protective cover	18
Mounting the sash on the drive bracket.	18
Installing the control unit	19
Securing the hinges	19
Installing the coupling rod	20
3 Electrical installation	
Connection	22
Identifying motor 1	26
Connecting motors	27
Connecting the power supply	27
Connecting the pushbutton	28
Connecting the wireless transmitter	28
4 Operation	
Commissioning	30
Programming end positions	30
Teaching in sashes	30
Ventilation position (symmetrical)	31
Radio range	31
Synchronising the wireless transmitter	32
Deleting the wireless transmitter	28
Electromagnetic lock set	33
5 Maintenance	
Troubleshooting	34
CE EC Declaration of Conformity	35

Explanation of signs and symbols

Warning notes

 DANGER
▶ Designates an imminent danger that could lead to death or severe injuries if the respective precautionary measures are not implemented.

 WARNING
▶ Means that death, severe bodily injury or major property damage could occur if the respective precautionary measures are not implemented.

 CAUTION
▶ Means a possible danger that could lead to minor injuries or property damage if it is not avoided.

- ▶ Directives for action

Safety notes

- ▶ Only qualified specialist personnel may carry out installation and commissioning!

 WARNING
Incorrect installation could lead to severe injuries and/or damage to property.
▶ Follow all installation instructions

 WARNING
▶ Take into account the following notes and warnings in order to avoid dangers and to protect the product.

- ▶ Observe the accident prevention regulations of the Accident Prevention & Insurance Association.
- ▶ Observe the rules of the road during transport.
- ▶ Make sure that the load is well-secured on the means of transport.
- ▶ Take care to ensure that the drives are stored under dry conditions prior to final installation and commissioning.
- ▶ Cordon off a generously large area around the installation site.
- ▶ Observe without limitation the regulations of the manufacturers of dowel and fitting materials.
- ▶ The mounting bases of the installation site are to be checked for load-bearing capacity prior to installation.
- ▶ In the event of uncertainties about the mounting bases, contact your responsible building experts.
- ▶ Electrical work may be carried out only by authorised electricians.
- ▶ The specified connection diagrams are to be observed, as otherwise damage to the motor could occur. EHRET GmbH assumes no liability for damage resulting from incorrect installation.

- ▶ Check the product for damage prior to installation. Products requiring repair may not be used.
- ▶ Do not touch any internal parts of the product that become exposed as the result of damage (e.g. electrical cables/lines).
- ▶ Discontinue operation of your electrical drive at once in the event of smoke or fumes.
- ▶ Do not allow children to play with the operating apparatus of the drives.
- ▶ Electrical/electronic devices are not secure against failure. Make sure that no hazardous situations for personnel or product could arise in the event of a power failure.
- ▶ Devices with electrical controls could go into motion at any time and without warning. Prevent situations hazardous to personnel and product that arise from this fact.
- ▶ No personnel or obstacles are permitted to be within the range of pivoting and/or travelling shutters while they are moving. Keep personnel and objects away until the shutters have reached their final position.
- ▶ Do not reach into moving parts or closing areas while shutters are opening or closing.
- ▶ Make sure that no articles of clothing or body parts are able to be caught by moving parts in the system.
- ▶ Disconnect the drives from the power supply during maintenance work.
- ▶ Ice could form on the product in the event of snowfall, sleet or icy rain. Do not operate equipment until the ice formation is no longer present, and switch automatic controls to manual.
- ▶ Make sure that the shutters are locked before any wind load occurs.
- ▶ The shutters may not be operated at wind speeds from 62 km/h (stormy wind).
- ▶ No additional loads such as persons or objects are permitted to have an effect on the shutters.
- ▶ Shutters are not intended to protect individuals from falls.

 **WARNING**

Danger of injury from the weight of the product!

- ▶ Due to the weight of the products, transport and installation must be carried out by at least two individuals.

- ▶ Transport the product carefully in order to avoid damage.
- ▶ Take care to ensure that the product is not damaged when the packaging material is removed.

 **WARNING**

Danger of suffocation from packaging foil.

- ▶ The packaging foil must be kept out of reach of children.
- ▶ Store the foil carefully until you turn it in for recycling.

- ▶ Turn the packaging materials in for recycling.

Installation FAQs

Which parts have been delivered?

- Bracket drive (230 V - 24 V DC +/- 10%)
- Wireless remote control or pushbutton
- Control unit
- Drilling template for façades, retaining rings, fastening screws, stop angles, stop buffers

Which means of attachment are being used?

- The fitting materials are not included in the scope of delivery!
- The selection of the fitting materials is based on the mounting bases on hand, the load-bearing capacities of which are to be checked before the installation. Observe without limitation the regulations of the manufacturers of dowel and fitting materials.



WARNING

Danger of injury/property damage caused by unsuitable fitting materials

- ▶ The fitting materials are to be selected in accordance with the load-bearing capacity of the mounting bases.

Electrical installation



DANGER



Danger of death from electric shock

- ▶ Only trained specialists are permitted to carry out the installation.

NOTES

- The connection (Phase L) must be equipped with a line safety switch with a maximum nominal current of 6 A.
- The line safety switch must have a switch-off capacity of at least 6 kA.
- The prescribed tripping characteristic is B.
- The line switch should be equipped with a thermal tripping device for overload protection; furthermore, it should have an electromagnetic trigger as a protection against short circuits.
- Other requirements may apply to the installation of the line safety switch, depending on the location. For example, it could be necessary to use a line safety switch with additional separation of Phase N in order to switch off all poles. It might possibly also be necessary to have a residual current circuit breaker in the system. The standards and the laws of the respective country with respect to permanent electrical installations are to be complied with (e.g. VDE 0100).
- It is recommended that no more than five drives are protected simultaneously by a single line safety switch.
- Pursuant to VDE 0100 and/or the statutory regulations and standards of the respective country, the permanent electrical installation must be carried out by a certified electrician.
- According to VDE 0022, the operator and the installer are responsible for compliance with the VDE regulations and/or regulations of the energy supplier.

Disposal



IMPORTANT

Disposal

- The following information must be strictly adhered to in order to prevent any environmental damage. Even if the machine is disposed of by certified experts, the operator must ensure proper execution!

Some materials are reusable. By recycling some parts or raw materials from used products, you make an important contribution to protecting the environment.

- ▶ Please contact your local authorities if you require information about collection points near you.



IMPORTANT

Disposal

- ▶ Dispose of any machine parts in such a way that damage to human health and the environment can be excluded.

Hazardous waste

Reusable material	Components
Electronic waste	<ul style="list-style-type: none"> • Electrical supplies • Controls • Circuit boards with electronic components

Recyclable materials

Reusable material	Components
Aluminium	<ul style="list-style-type: none"> • Window shutters • Drive housing • Fittings
Copper	<ul style="list-style-type: none"> • Cables • Motor
Plastic, rubber, PVC	<ul style="list-style-type: none"> • Accessories • Seals • Cables
Steel	<ul style="list-style-type: none"> • Motor and components • Coupling • Brackets • Fittings • Accessories

1 Product description

Product properties

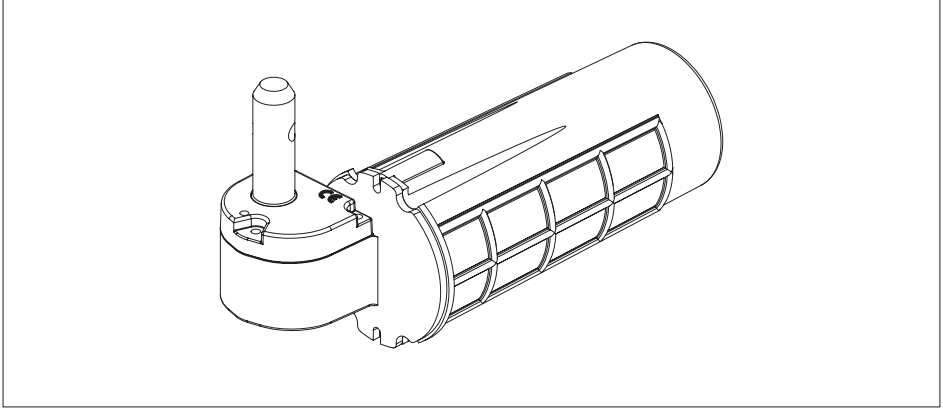

- The E-motion is an invisible bracket drive system for max. 2 sashes per side for the electrical actuation of window shutters.
- The drive is equipped with radio technology and is suitable for all types of window shutters.
- It is operated using remote control via a hand-held transmitter (2-channel), radio frequency 433.92 MHz or pushbutton control
- Drive control using bus systems under the responsibility of the customer!

Technical data

<i>Voltage supply</i>	230 V – 24 V DC +/- 10%
<i>Opening or closing time</i>	18 sec.
<i>Clear width length according to specifications</i>	
<i>with 1 motor</i>	280 – 1600 mm
<i>with 2 motors</i>	560 – 3200 mm
<i>Area on each side</i>	1 sash: 1.6 m ² 2 sashes: 3.2 m ²
<i>Weight per drive</i>	max. 50 kg
<i>Operating temperature</i>	-30°C to +70°C

<i>Operation</i>	Wireless hand-held transmitter 433.92 MHz or pushbutton control
<i>Torque nom.</i>	25 Nm per motor
<i>Speed</i>	1.9 rpm
<i>Connection Cable for:</i>	
<i>Power supply</i>	3-wire, 1,5 mm ²
<i>Control unit</i>	2-wire, 1,5 mm ²
<i>Motor</i>	2-wire, 0,75 mm ²
<i>Power consumption</i>	100 W
<i>Disconnection</i>	Load switch-off (stops at obstacles)

Wiring diagram

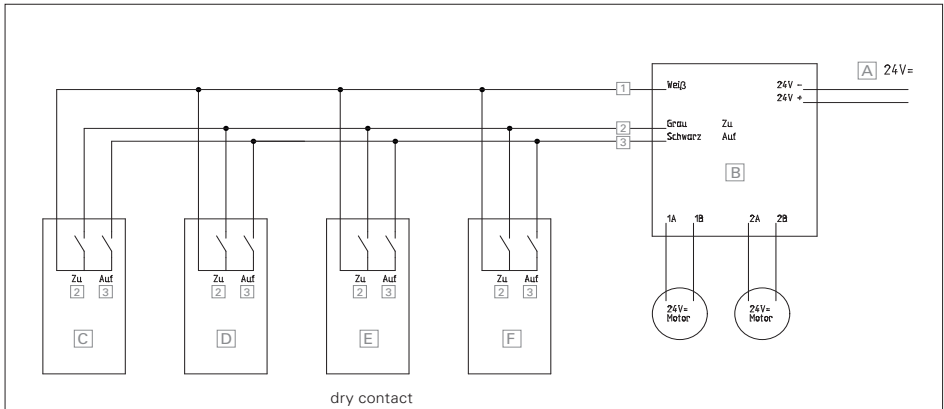

A Supply cable 24 V=

B Control unit push-button

C KNX actor push-button

D Venetian blind push-button

E Timer

F Sun/wind control

1 white cable

2 grey cable (close)

3 black cable (open)

Smart Home System

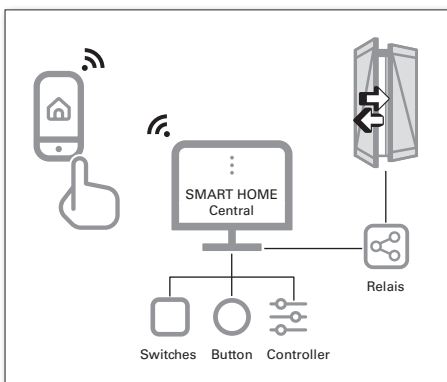

- The E-motion bracket drives are suitable for SmartHome connection.
- Because not all systems and products are compatible with each other, all areas of application should be considered and an enquiry made to EHRET GmbH before purchase.

Scope of delivery

E-motion

EHRET bracket drive

Diagram 1L, 2L
with 1 motor

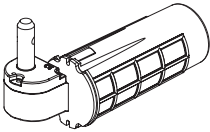

Diagram 1R, 2R
with 1 motor

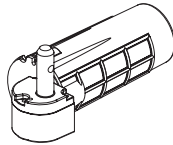
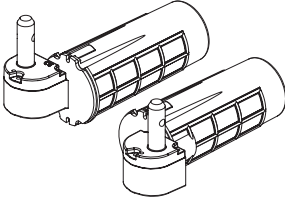

Diagram 2, 3L/3R, 4
with 2 motors



Accessories of the drive housing



Sealing grommet

INFO The sealing grommet supplied is used to seal the cable outlet area on the back of the drive housing to prevent water from penetrating.

The sealing grommet is used on site by client (see □ Chap. „Sealing the drive housing,” p.14) and is absolutely necessary for the warranty!

Contained in the scope of delivery

Pushbutton

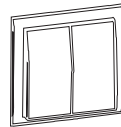

Wireless hand-held transmitter

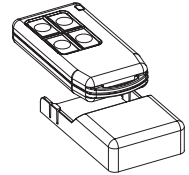

or

Control unit

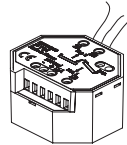

for pushbutton

or

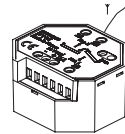

for wireless

Accessories for each side



Perforated sleeve for fastening



Drilling template for façades



Motor cover



Sealing rings



Protective ring for pin



Locking bush

2x blade receptacle

2x M4  S1

2x M3  S2

1x N1 

INFO The locking bush is considered a predetermined breaking point to protect the drive under heavy load.

It can be reordered in case of breakage.

Accessories*

*not included in the scope of delivery

Sealing for each drive

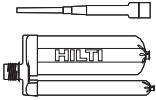

4450 HILTI injectable mortar, HIT-HY 50, 330 ml, incl. cartridge nozzle

Switching power supply

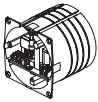

6560 Concealed
max. 4 drives,
drilling dimensions:
Ø68 × 80 mm

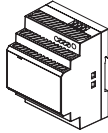

6561 Surface-mounted
max. 4 drives



6562 Switch cabinet
max. 16 drives

Options



6566 Wireless push-button (white)

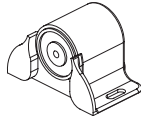

6575 Electromagnetic lock set

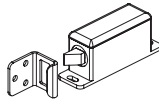

Lock bolt
6576 left
6577 right



Spacer ring
6572 8 mm
6578 12 mm
6573 17 mm



6045 Stop button, plastic, black, 30/40/50/60 mm



6047 Coupling for multiple-section sashes, 600 / 1000 mm



Bolt stop
5303 50 mm
5304 100 mm



10020 Stop buffer, self-adhesive,

Tools required*

*not included in the scope of delivery

Concrete drill bit Ø 16 mm



Drill Ø 4,2 mm

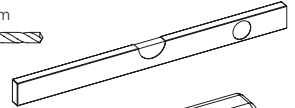

WAF 5

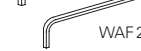

WAF 2.5

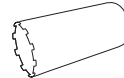
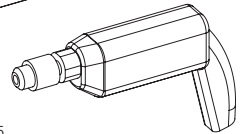

Diamond drill bit
Ø 67 mm / Ø 68 mm



Connection Cable for:
Power supply (3×1.5 mm²),
Control unit (3×1.5 mm²),
Motor (2×0.75 mm²)

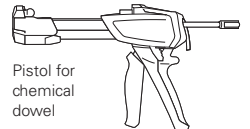

Pistol for chemical dowel

2 Installation instructions

Preparation

NOTE

When installing the bracket drive, a minimum distance of 40 mm from the bracket pin centre to the outer edge of the sash is required.

WITH EXISTING BRACKETS

Checking the bracket spacing

The distance from the bracket pin centre to the outer edge of the window shutter must be 40 mm.

- ▶ Adjust all hinges accordingly
- ▶ Remove the existing brackets and fill the resulting holes in the façade

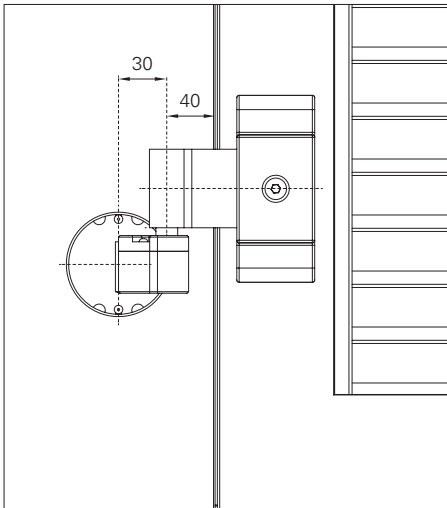

Positioning the bracket drive

In the case of shutters with 2 hinges per sash, either the upper or lower brackets can be motorised. In the case of 3 hinges, we recommend motorising the middle bracket.

- ▶ Remove the selected existing bracket pair
- ▶ Fit the stop button at the height of the bracket drive being installed

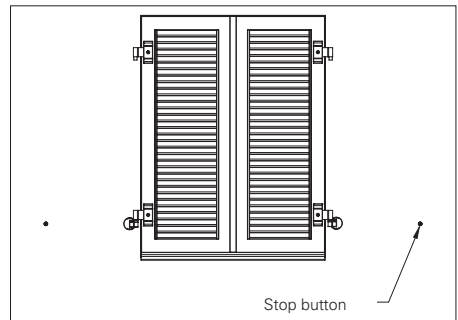

Checking the stop angles

The stop angles are required for fault-free operation of the bracket drive.

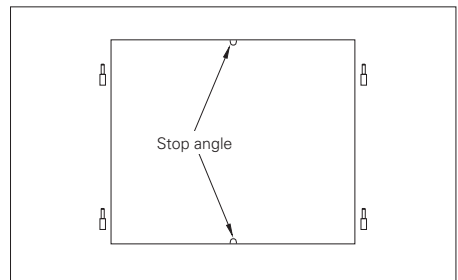

Marking the drill holes

NOTES

Make sure that the axes of the hinges are vertical!

- ▶ Close and secure the sashes
- ▶ Place the drilling template for façades on the hinge
- ▶ Mark the drill hole with a pencil

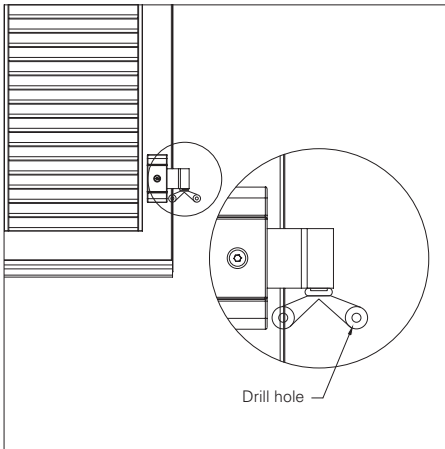

Drilling the wall

⚠ CAUTION

Risk of injury due to incorrect operation of the drill

- ▶ Follow the safety instructions from the hammer drill manufacturer!
- ▶ Never use the hammer function!

NOTES

Make sure you maintain a right angle to the wall both vertically and horizontally at all times during drilling!

Carefully clean the drill holes with a vacuum cleaner and wire brush. The dowels will not hold if there is dust in the hole.

- ▶ Remove the window shutters
- ▶ Place the hammer drill in the drilling position
- ▶ Fasten the diamond drill bit in place and attach the drill bush (drill diameter \varnothing 67/68 mm).
- ▶ Remove the drill bush and keep drilling until the hole is 150 mm deep

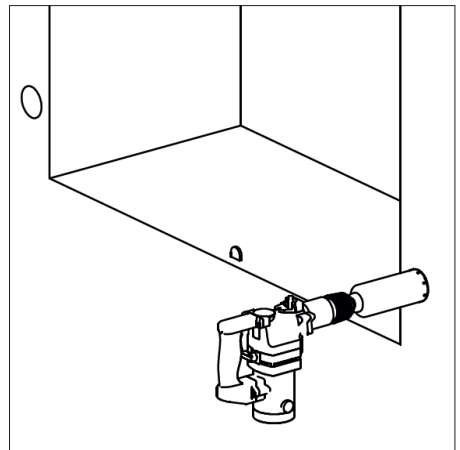

- ▶ Drill the holes for feeding through the cable hose with a 16 mm drill bit

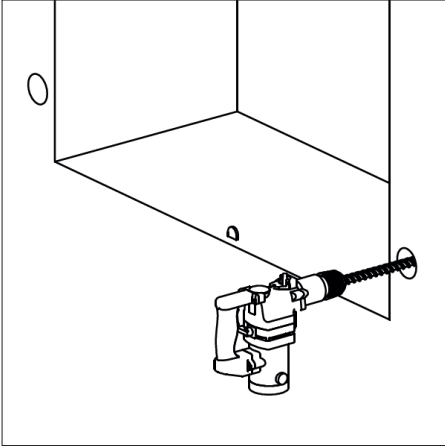

Sealing the drive housing

⚠ CAUTION

Damage to the motor due to water ingress

- The functionality of the bracket drive can only be guaranteed as long as no moisture gets inside the drive housing.
- For sealing, EHRET supplies a sealing grommet for the rear area of the cable outlet and a sealing ring for the front area of the drive housing.
- Nevertheless, depending on the construction situation (e.g. uneven facade, porous wall,...), moisture penetration cannot be ruled out, so that the critical points must be additionally sealed with silicone on site!

- ▶ Insert the supplied sealing grommet
- ▶ Seal all sensitive areas of the drive housing with additional silicone.

Insert sealing grommet

- ▶ Remove the 2 locking screws from the bracket drive

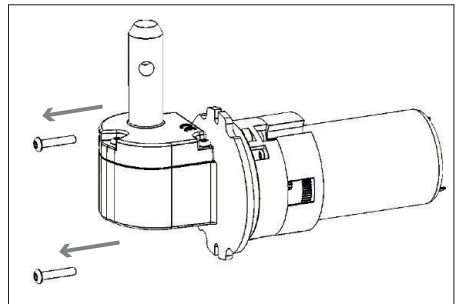

Inserting the bracket drive

- ▶ Remove the motor from the drive housing

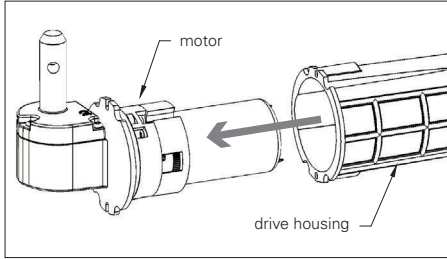

- ▶ Insert the supplied grommet into the recess for the cable outlet on the back of the drive housing

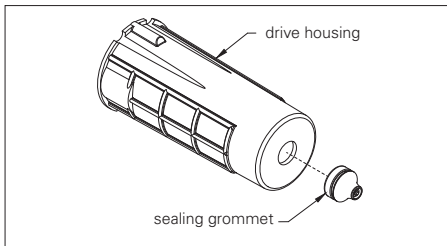

Additionally seal with silicone

- ▶ Also seal the rear in the area of the cable outlet and the front area of the drive housing with silicone!

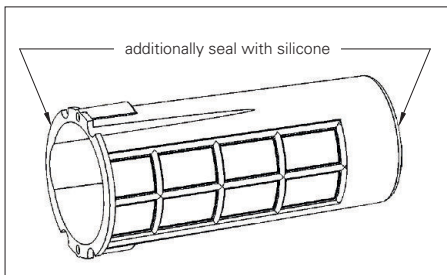

NOTES

- Make sure there is a wire length of 200 mm beyond the wall!
- The use of the spacer ring is absolutely necessary for installation types 2, 3, 4!

- ▶ Bring the cable hose for the electrical connection up to the drive housing

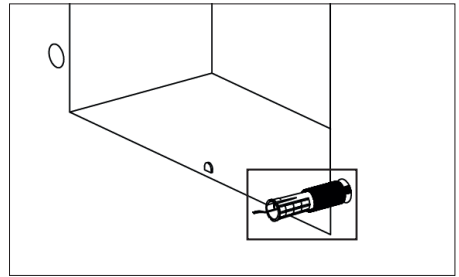

- ▶ Insert the perforated sleeve supplied with the dowel kit and if necessary spacer ring into the hole along with the drive housing.

- ▶ Guide the cable hose through the drive housing

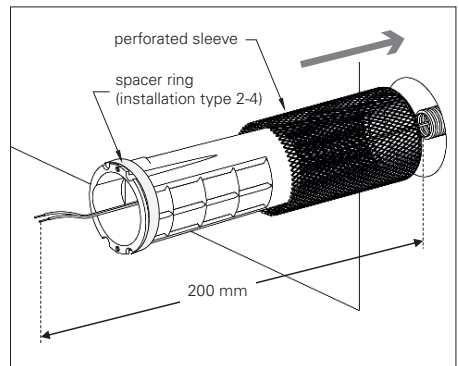

- ▶ Guide the wires through the sealing ring
- ▶ Connect the wires and refit the housing

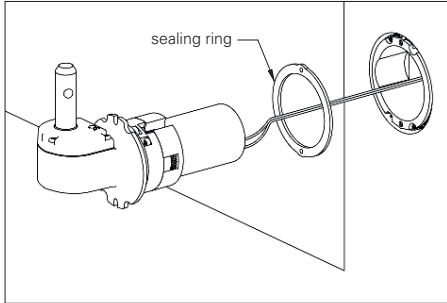

Twisting the wires

NOTES

Crushing the cables can cause the cables to break.

- ▶ Turn the motor several times to twist the wires
- ▶ Reassemble the housing

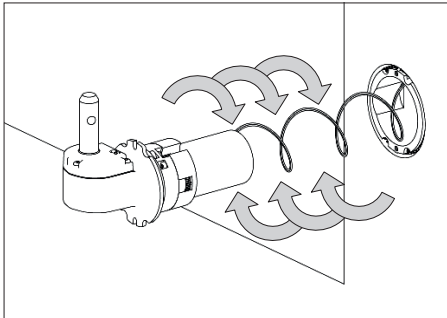

NOTES

Make sure that the brackets are precisely vertical!

- ▶ Place protective rings on the two motorised brackets on the left and right
- ▶ Mount the shutters on top
- ▶ Fasten the brackets to the hinges

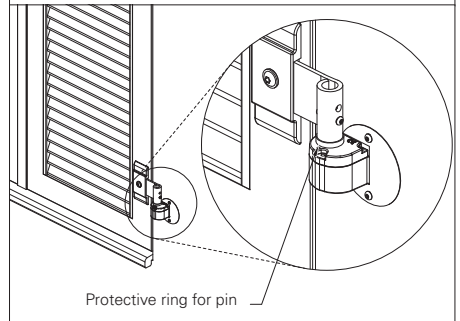
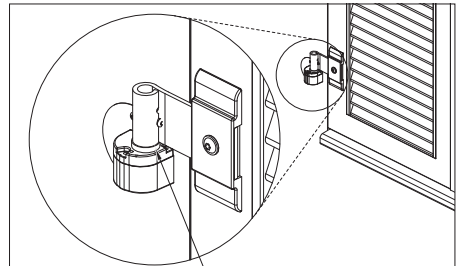

IMPORTANT

- ▶ With installation type 4, mount the hinge with the cranking towards the inside!

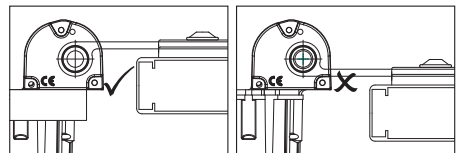

Fit the chemical dowels

NOTES

Make sure that the brackets are precisely vertical. Follow the instructions from the manufacturer of the injectable mortar!

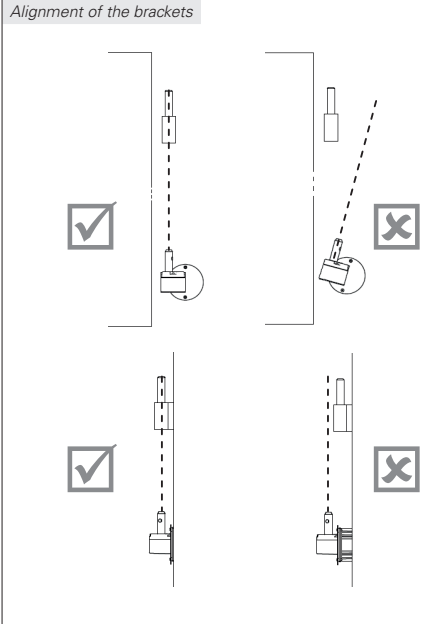

- ▶ Prepare the supplied 330 ml cartridge and cartridge nozzle

Inject the injectable mortar into the motor channels as follows:

- ▶ Two squirts at the base of the perforated sleeve
- ▶ Three squirts along the wall
- ▶ Four squirts in the designated holes (A, B, C, D)
- ▶ Fill the cavity around the motor housing evenly (E)

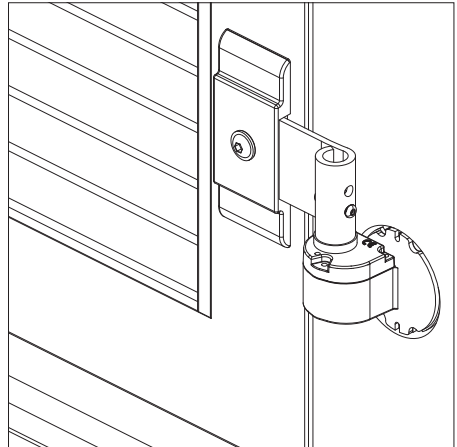

- ▶ Wipe away any mortar that emerges with a damp sponge
- ▶ Leave the mortar to harden (see manufacturer instructions)

Fitting the protective cover

NOTES

EHRET recommends a silicone seal around the motor cover to prevent moisture from getting into the product.

- ▶ Fasten the motor cover in place with S2 SCREWS (M3)

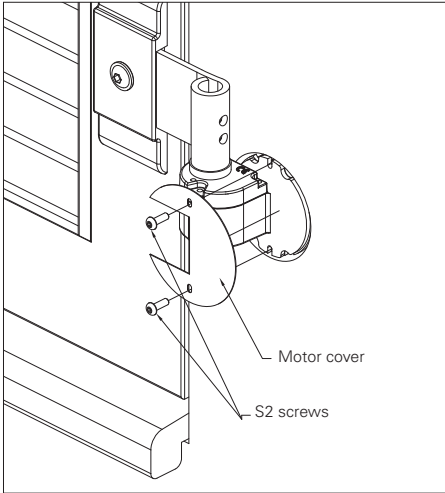

- ▶ Use silicone to seal around the motor cover

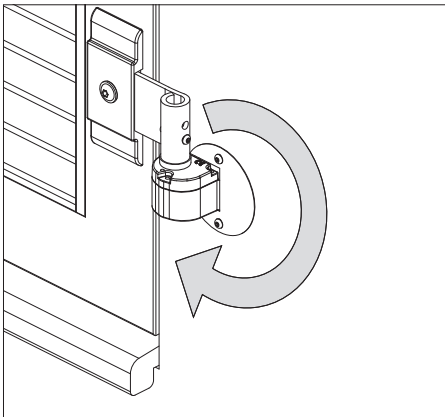

Mounting the sash on the drive bracket

- ▶ Remove the shutters
- ▶ Remove the protective rings

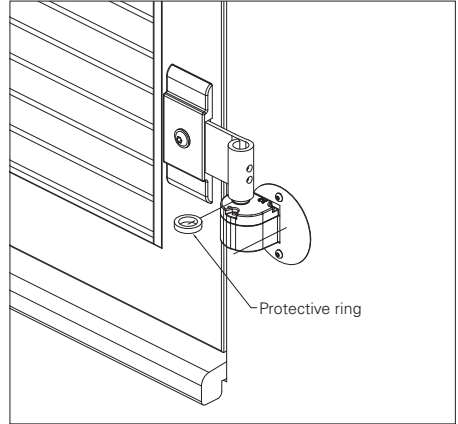

- ▶ Refit the shutters
- ▶ Apply locking varnish to the 2 M4 screws
- ▶ Fit the locking bush and screw in place with the 2 S1 SCREWS (M4)

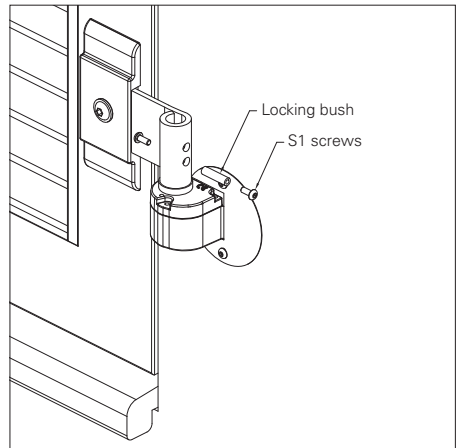

Installing the control unit

WIRED PUSHBUTTON CONTROL

- ▶ For wire kits, embed a 60-mm-deep wall box into the wall in the house
- ▶ Connect the wires according to the circuit diagram

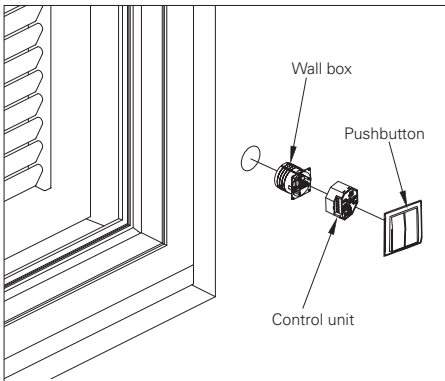

REMOTE CONTROL

- ▶ The housing can be installed in a false ceiling, in the wall cladding, in a wall box, etc. as required.

Securing the hinges

NOTES

Steel hinges used must be secured against shifting when installing the E-motion bracket drive as follows:

- ▶ Close and align the shutters and stabilise them with wooden wedges in the reveal.
- ▶ Loosen screw S3 and remove the hinge holder.
- ▶ Drill through pre-drilled upper rivet hole L1 in the frame with drill \varnothing 4.2 mm and rivet flush with rivet N1.
- ▶ Reinstall hinge holders.

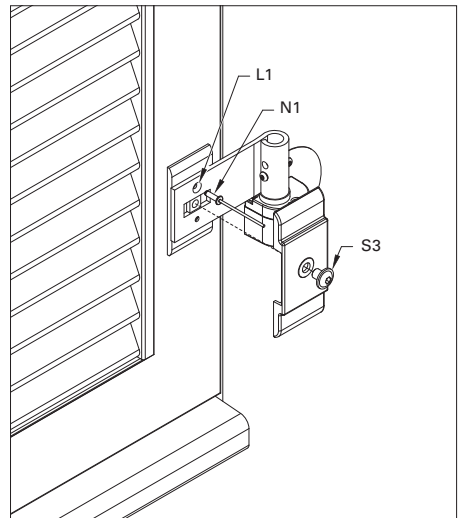

Installing the coupling rod

FOR MULTIPLE-SECTION SASHES
Diagram 2L/2R, 3L/3R, 4

- ▶ Position the coupling lug through the drill holes and on the window shutter

IMPORTANT: The horizontal distance between the drill holes and frame edge is 46 or 74 mm; the installation height of the coupling lug (dimension Y) is to be specified by the customer. Depending on the structural situation, please be aware that there may be a rabbet or projection of the window shutter.

- ▶ Mount the coupling lug on the window shutter

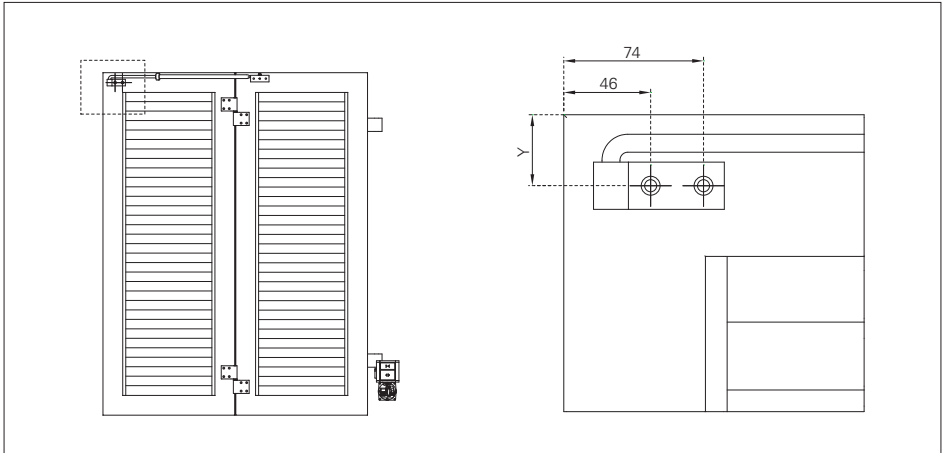

- ▶ Close the double shutter
- ▶ Mark the centre of rotation **A** of the coupling lug in the lintel

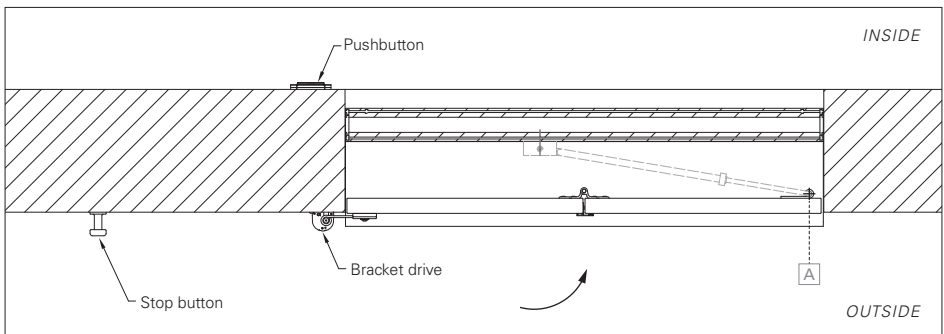

- ▶ Open the double shutter
- ▶ Measure the distance [AB] from the centre of rotation of the coupling lug when it is closed [A] to its centre of rotation when open [B]

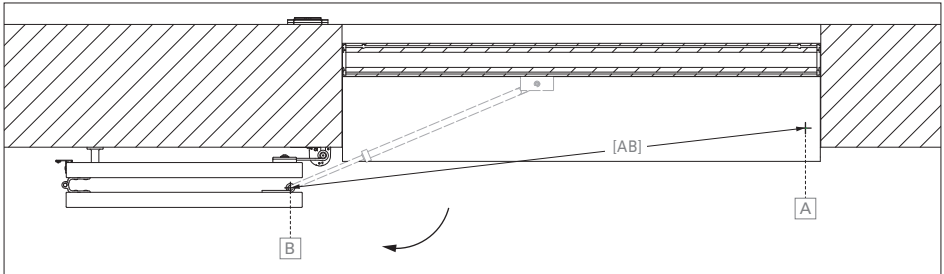

- ▶ Close the double shutter and divide the distance determined [AB] in half
- ▶ Starting from centre of rotation [A] mark the halfway point $\frac{1}{2}$ [AB] in the lintel above the window frame. This is marking point [C]

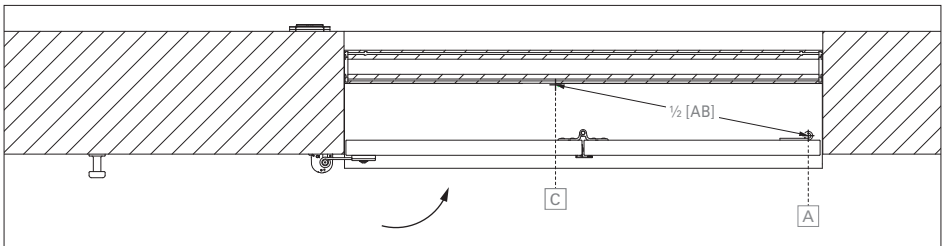

- ▶ Open the double shutter
- ▶ Starting from centre of rotation [B] mark the halfway point $\frac{1}{2}$ [AB] in the lintel above the window frame. This is marking point [D]
- ▶ The centre of marking points [C] and [D] produces centre of rotation [E] of the coupling rod

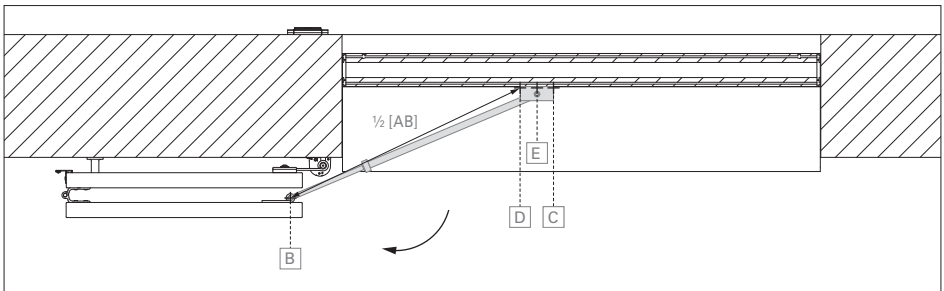

- ▶ Fasten the coupling rod bracket at the centre of rotation [E] of the coupling rod

3 Electrical installation

Connection

⚠ WARNING

Electrical shock (230 V)

- ▶ Electrical installation must be carried out in accordance with the applicable national standards as well as all relevant statutory and/or binding provisions.
- ▶ When establishing the electrical connection, the voltage must be switched off: do not switch the power on until all installation work is complete.
- ▶ Do not use any pushbuttons other than the one provided with the kit
- ▶ The 220 V-24 V power supply must fulfil the applicable standards

REMOTE CONTROL

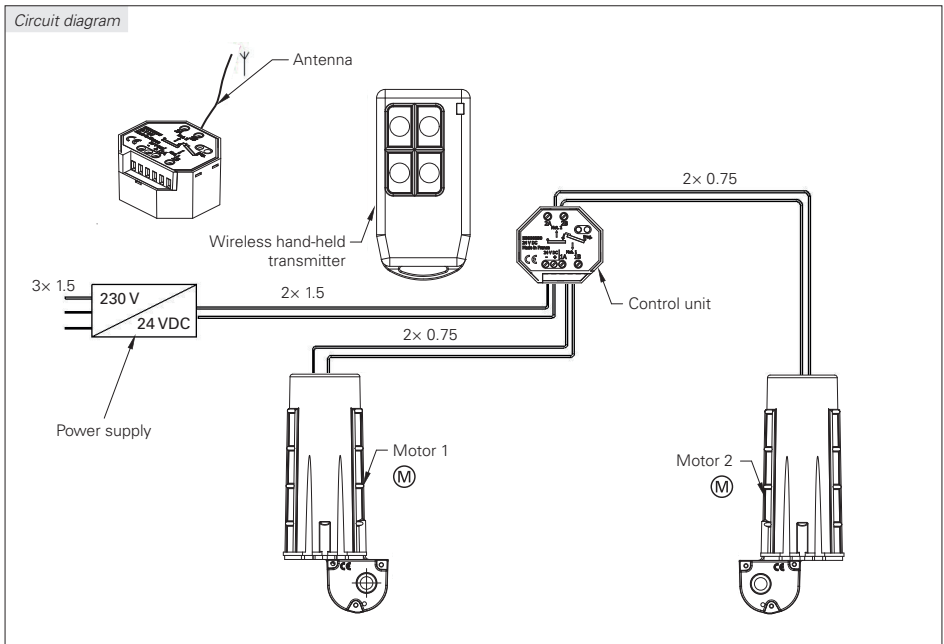

- The length of the cable between the control and the switching power supply or the control and the motor must not exceed 100 m.

WIRED PUSHBUTTON CONTROL

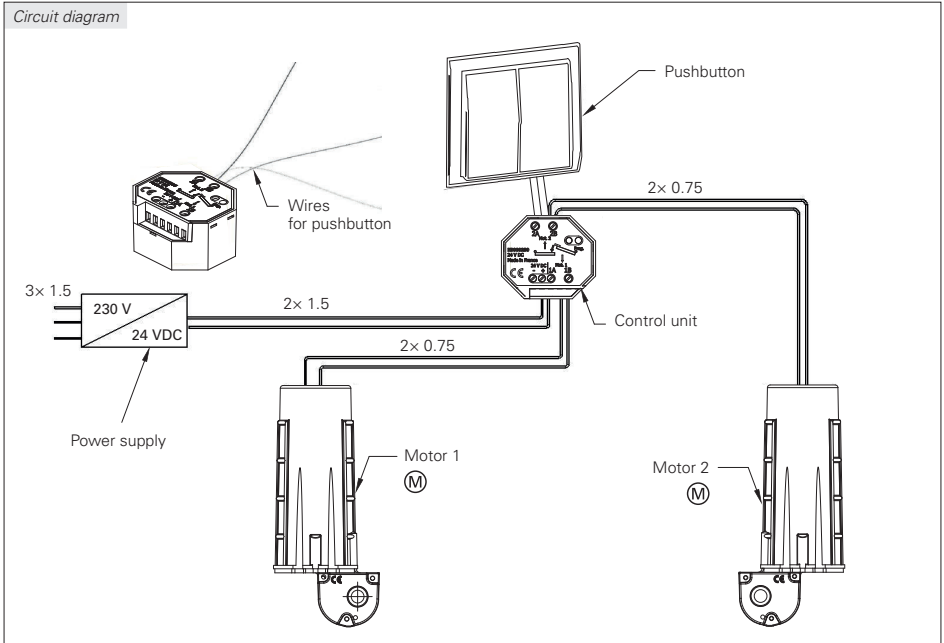

- The length of the cable between the control and the switching power supply or the control and the motor must not exceed 100 m.

INSTALLATION EXAMPLE

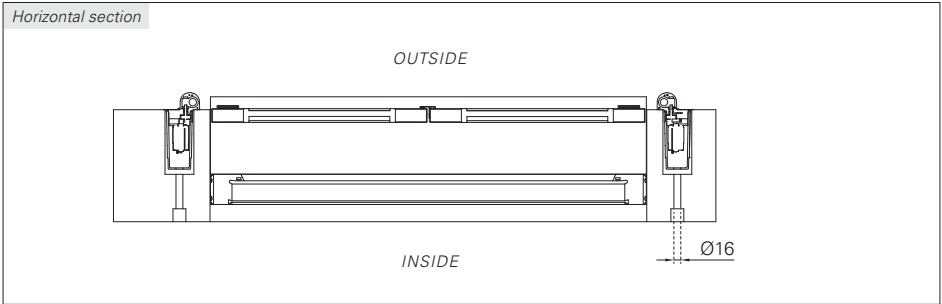
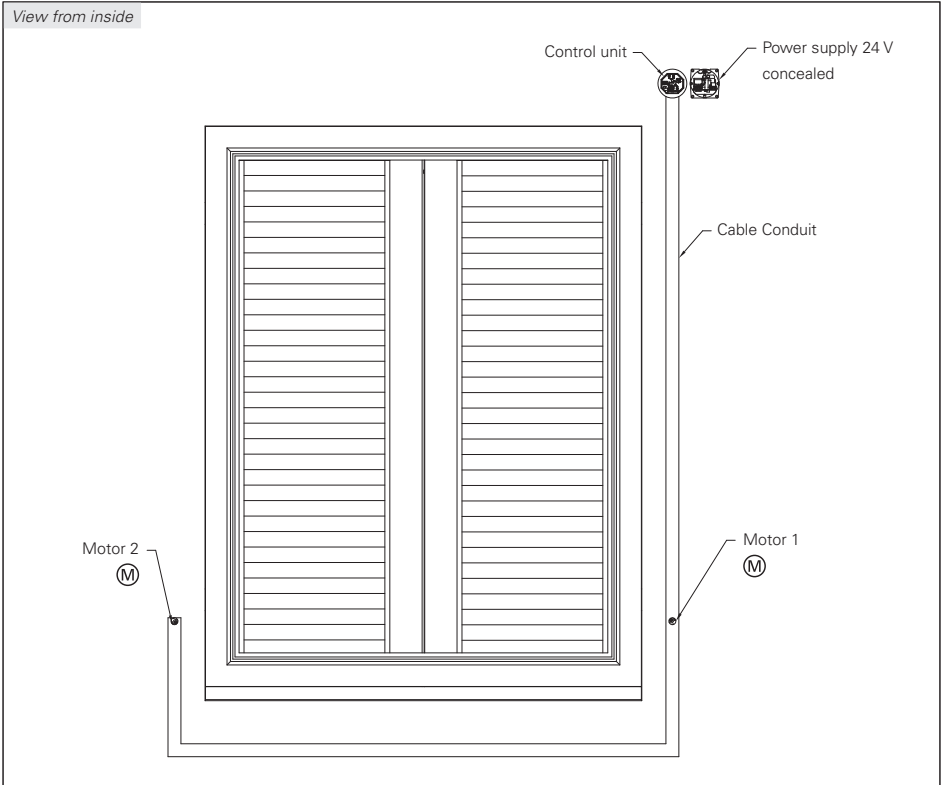

*CONCEALED SWITCHING
POWER SUPPLY 24 V*

NOTES

- Connection diagram included in the scope of delivery of the switching power supply
- Switching power supply 24 V incl. housing, no additional concealed socket needed
- Drilling dimensions: $\varnothing 68 \text{ mm} \times 80 \text{ mm}$
- Cable entry from top rear

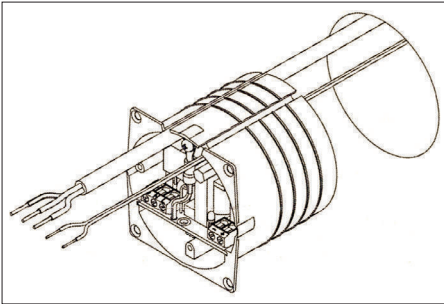

Cable entry

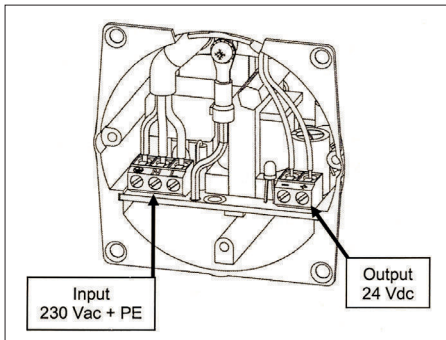

Electrical connection

Identifying motor 1

- ▶ Motor 1 moves the outside sash which features the T-bead

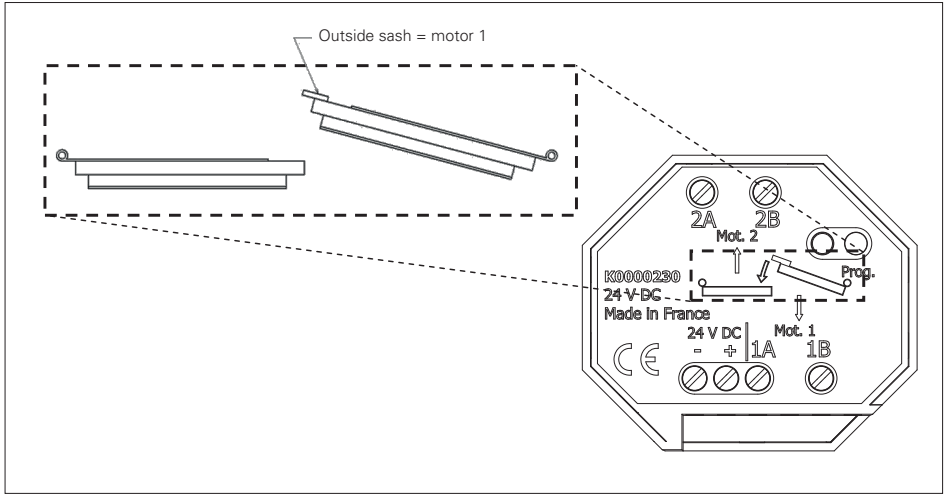

Connecting the pushbutton

- ▶ Remove the OPEN and CLOSE buttons from the pushbutton cover

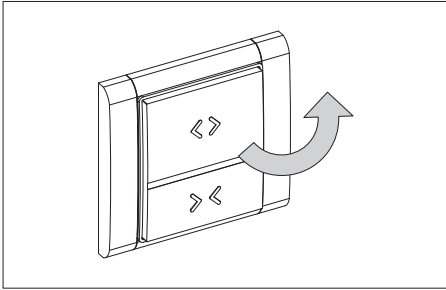

- ▶ Press one of the buttons and, at the same time, guide the wire into one of the two cavities below the controls.

Releasing the button will clamp the wire in the cavity.

- ▶ Check this by pulling gently on the wire
- ▶ Repeat this process for the other two wires

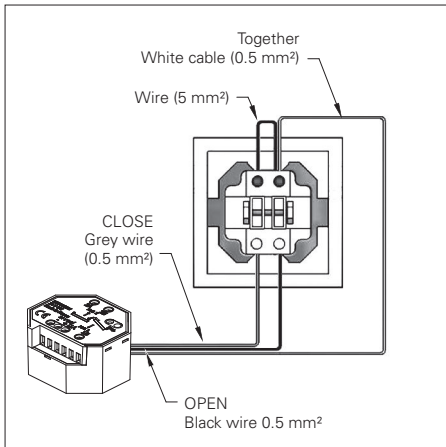

Connecting the wireless transmitter

- ▶ Screw or glue the wireless transmitter into place in a location of your choice at least 20 m from the control unit

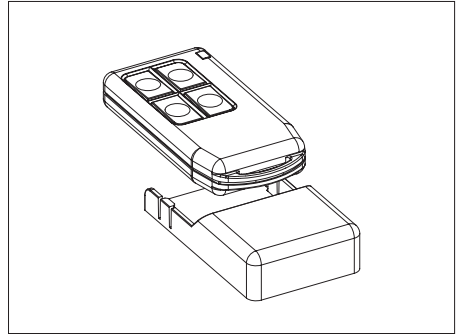

4 Operation

Commissioning

NOTES

The EHRET bracket drive features an obstacle detection function.

If the opening or closing movement encounters an obstacle, the direction of movement reverses and the sash returns to its original position.

The motors run slowly until the teach-in process is complete.

- ▶ Switching on the system

Wireless products only:

- ▶ Synchronise your wireless transmitter, following the instructions for wireless synchronisation.

Controls

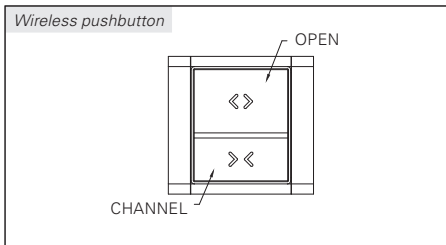
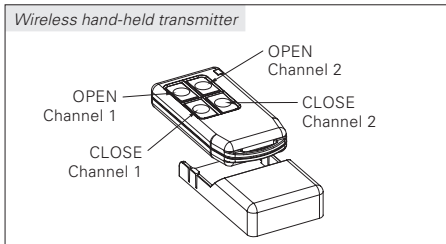

Programming end positions

⚠ CAUTION

Damage to the belts due to non-programmed end positions

- The end positions of the sashes must be programmed prior to operating the bracket drive!
- Operating the E-motion bracket drive without programmed end positions can damage the hinges!

NOTES

The teach-in cycle of the end positions must not be interrupted!

Do not operate any buttons or hand-held transmitters and do not manually reach into the wings until the teach-in cycle is complete.

- ▶ Press the PROG button with a small screwdriver

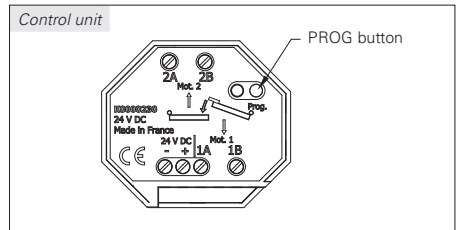

The learning cycle starts:

- The shutters open and close completely to define the end positions.
- The LED flashes throughout the entire cycle.
- The closing process for the second sash starts with a delay of 6 seconds after the first sash.

After the window shutter is closed and the LED is no longer flashing, the system is ready for operation.

Operate shutters

Opening and closing

- ▶ Press the OPEN button

The window shutter opens and stops automatically when it reaches the stops.

- ▶ Press the CLOSE button

The window shutter closes completely.

Stopping the sashes

- ▶ Repeat the last command

(*OPEN button during the opening process, CLOSE button during the closing process*)

The window shutter stops immediately in an intermediate position.

Ventilation position (symmetrical)

NOTES

- The ventilation position (symmetrical opening angle of the wings) can only be adjusted in the opening direction.
- In the closing direction, the leaves remain at an asymmetrical angle to each other when a stop command is given.
- The opening angle can be set arbitrarily.

The wings must first be fully closed.

- ▶ Press the OPEN button

The shutters open. As soon as the desired opening angle is reached:

- ▶ Press the OPEN button again

The trailing wing catches up with the leading wing so that both folding shutters stop at the same opening angle.

Radio range

NOTES

The strong propagation of radio waves depends on the type of environment they are travelling through. The range of the radio waves will be longer or shorter depending on the type of construction.

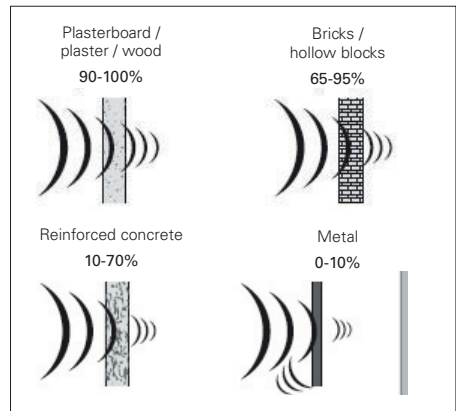

Synchronising the wireless transmitter

NOTES

During programming, the LED will go out if there is no activity for 20 seconds and the system will return to normal mode. The commands must then be entered again from the beginning.

Synchronising the wireless hand-held transmitter

- ▶ Hold the PROG button down for approx. 5 sec.

The LED lights up permanently (system in "Wireless synchronisation" mode).

- ▶ Press the OPEN and CLOSE buttons for the desired channel at the same time

The LED flashes rapidly and goes out: the wireless hand-held transmitter is synchronised.

Synchronising the wireless pushbutton

- ▶ Hold the PROG button down for approx. 5 sec.

The LED lights up permanently (system in "Wireless synchronisation" mode).

- ▶ Press the OPEN and CLOSE buttons on the wireless pushbutton at the same time

The LED flashes rapidly and goes out: the wireless pushbutton is synchronised.

Deleting the wireless transmitter

NOTES

If the system is in "Delete wireless synchronisation" mode, the LED is switched off by pressing the PROG button briefly. The system then returns to the normal function mode.

Deleting the wireless hand-held transmitter

- ▶ Hold the PROG button down for approx. 5 sec.
The LED lights up permanently (system in "Wireless synchronisation" mode).

- ▶ Press the PROG button briefly
The LED flashes slowly (system in "Delete wireless synchronisation" mode)

- ▶ Press the OPEN and CLOSE buttons on the wireless hand-held transmitter at the same time
The LED flashes rapidly and goes out: the wireless hand-held transmitter is deleted.

Deleting the wireless pushbutton

- ▶ Hold the PROG button down for approx. 5 sec.
The LED lights up permanently (system in "Wireless synchronisation" mode).

- ▶ Press the PROG button briefly
The LED flashes slowly (system in "Delete wireless synchronisation" mode)

- ▶ Press the OPEN and CLOSE buttons on the wireless pushbutton at the same time
The LED flashes rapidly and goes out: the wireless pushbutton is deleted.

Deleting all wireless transmitters

- ▶ Hold the PROG button down for approx. 5 sec.
The LED lights up permanently.

- ▶ Hold the PROG button down for approx. 5 sec. again
The LED flashes rapidly and goes out: no switches are synchronised any more and learning is also deleted.

Electromagnetic lock set

option

NOTES

The electromagnetic lock set is an optional locking element and is not included in the scope of delivery!

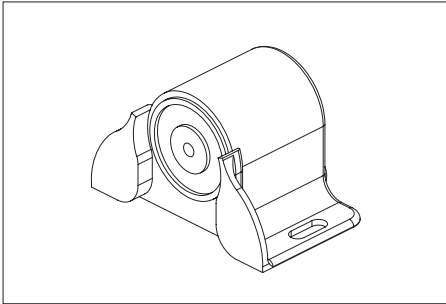

When the end position is reached (opening/closing process), the end switch switches to the output voltage after 300 ms.

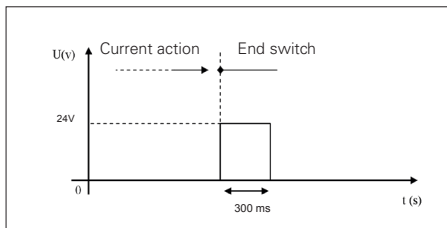

Voltage between output and status –(GND) at the end of the movement

Electrical lock connection

- ▶ Connect the electrical lock to inputs 1A and 1B on motor 1

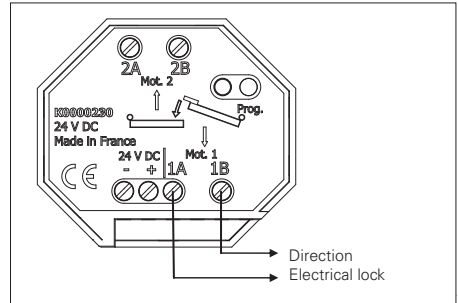

STATUS output connection

Only in combination with a wired home automation system:

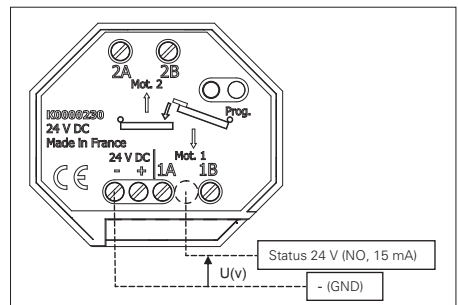

Troubleshooting

Problem	Possible cause(s)	Solution(s)
Motors are not running	The control unit is not receiving any power	Check the control unit connection to the power supply; check the mains connection for the 24 V power supply (see installation instructions)
Motors running slowly	Teach-in process incorrect	Repeat teach-in process (see operating instructions)
Motors do not slow down when the end position is reached	Teach-in process incorrect	Repeat teach-in process (see operating instructions)
Window shutters do not move during teach-in process	Teach-in process started with window shutters open	Close window shutters and repeat teach-in process (see operating instructions)
The overlapping window shutter reaches the closed position first	Connection of motor 1 and motor 2 wrong way round	Swap the motor connections round: connect motor 1 in place of motor 2 and vice versa (see operating instructions)
Window shutters open when close button is pressed	Motors connected incorrectly	Check motor connections (see operating instructions)
	Wired operating button connected incorrectly	In the case of the wired version: check operating button connection (see operating instructions)
When the close button is pressed, one of the window shutters opens and the other closes	One of the motors is connected incorrectly	Check motor connections (see operating instructions)
The window shutters close when the open button is pressed	Motors connected incorrectly	Check motor connections (see operating instructions)
	Wired operating button connected incorrectly	In the case of the wired version: check operating button connection (see operating instructions)
When the open button is pressed, one of the window shutters opens and the other closes	One of the motors is connected incorrectly	Check motor connections (see operating instructions)
The window shutter movement is jerky	Window shutter fitted incorrectly	Check whether the window shutter moves freely and without resistance
The window shutter starts to move and then returns to its original position	Window shutter fitted incorrectly	Check whether the window shutter moves freely and without resistance
	Obstacle in the way	Remove the obstacle
The window shutter does not close/open completely	Window shutter fitted incorrectly	Check whether the window shutter moves freely and without resistance
	Obstacle in the way	Remove the obstacle
The window shutter goes too far when closing	End stops missing	Check whether there is a window shutter end stop present at the top and bottom.
Motor running but window shutter does not open (or close)	Connecting screws for hinges missing or broken	Insert new screws
The window shutter does not move when open/close command is issued	Control system defective	In the case of the wired version: check operating button connection; in the case of the wireless version: check battery state; the LED should light up when a button is pressed.

CE EC Declaration of Conformity

Déclaration de conformité « CE » « CE » Declaration of conformity

WIMOVE SARL, 66 Avenue du General De Gaulle - 21110 GENLIS - France

Déclare que le produit désigné ci-dessous :

Declare that the Product:

Description : Dispositif pour motorisation de volet battant
Modèle : **WIBAT**

Est conforme aux dispositions des directives Européenne suivantes :

Is in conformity with the following European Directive

89/106/EEC	Directive Européenne des Produits de la Construction / <i>Construction Products</i> (N.B. Produit mis en œuvre sur chantier)
2006/95/EEC	Directive Européenne Basse tension / <i>Low Voltage</i>
2006/42/EEC	Directive Européenne Machine / <i>Machinery</i>
2004/108/EEC <i>Compatibility</i>	Directive Européenne Compatibilité Electromagnétique / <i>Electromagnetic</i>
1999/5/EC	Directive Européenne Equipements Hertziens et les Equipements Terminaux de Télécommunications / <i>Radio and Telecommunications Terminal Equipment</i>
2002/95/EC	Directive Européenne Limitation de l'Usage de Certaines Substances Dangereuses dans les Equipements Electriques et Electroniques (RoHS) / <i>Restriction of the use of certain Hazardous Substances in electrical and electronic equipment</i>

et que les normes et/ou spécifications techniques mentionnées ci-après ont été appliquées :
and the standards and/or technical specifications mentioned below were applied :

EN 60335-1: 2002 + A11 :2004 + A1 :2004
EN 60335-2-103 : 2004
EN 301-489-1v1.6.1 : 2005

Sous réserve d'une utilisation conforme à sa destination, aux spécifications et instructions du constructeur, et d'une installation conforme aux normes en vigueur et aux recommandations du constructeur.

A condition is that it is used in the manner for with it is intended and in accordance with the specifications and instructions of the assembler, it is also required to conform to the existing standards.

Année d'apposition du marquage CE :
Year of apposition of the CE marking:

2008

Genlis, le 23/01/2008
M.IANNECE
Directeur Technique



EHRET GmbH

Aluminium shutters

Bahnhofstrasse 14-18

77972 Mahlberg, Germany

Tel. + 49(0) 78 22/439-0

Fax + 49(0) 78 22/439-116

www.ehret.com