



# VOLETRONIC Solar

Motorisation for window shutters



## Installation and operating instructions

INSTALLATION  
SPECIALIST PERSONNEL  
Valid from 01.2020

E 668.4

---

## Notes

These installation and operating instructions describe the commissioning of the VOLETRONIC Solar window shutter drive with wireless remote control.

Carefully read through these installation and operating instructions prior to commissioning. Observe the specified process steps and take into account the notes and recommendations given. Knowledge of and technically impeccable implementation of the given safety notes and warnings are prerequisites for the safe and proper operation of the VOLETRONIC Solar window shutter drive. Insufficient knowledge at the time of commissioning and utilisation lead to the loss of any liability claims against EHRET GmbH. Installation and/or operation in full or partial deviation from our installation and operating instructions will lead to the warranty for defects becoming void.

Installation of the shutters in accordance with the EHRET window shutter installation instructions is a prerequisite for the commissioning of the VOLETRONIC Solar window shutter drive.

These installation and operating instructions are addressed to qualified specialist personnel. Qualified specialist personnel are persons who are familiar with the transport, set-up, installation, commissioning and operation of the product and who have appropriate qualifications for their work. Specialist personnel must know and observe the relevant standards and/or guidelines.

These installation and operating instructions are a component part of the product and are therefore always to be retained until the product is disposed of. These installation and operating instructions are to be passed along in the event of the sale of this product.

This product complies with the general rules of technology. Safety-conscious behaviour is necessary for commissioning the product safely. For this reason, observe the following notes.

---

► *Remove the labels stuck to the shutters after installation!*

---

Should any of the information in these installation and operating instructions not be absolutely clear, it is essential that you contact the specialist personnel at EHRET GmbH, 77972 Mahlberg (Germany).

---

# Contents

Notes	2
Explanation of signs and symbols	4
Safety notes	4
<b>CE</b> EC Declaration of Conformity	6
Installation FAQs	8
Low-voltage instructions	8
Disposal	9
<b>1 Product description</b>	
Product properties	10
Technical data	11
Scope of delivery	12
<b>2 Installation instructions</b>	
Preparation	14
Mounting the installation profile and fastening the drive modules	15
<i>Variant A   Header installation</i>	16
<i>Variant B   Reveal installation</i>	17
<i>Variant C   Installed at the bottom</i>	18
Wiring the drive modules	19
Installation instructions solar panel	20
Fastening the solar module	22
Connecting the side cover	22
Connecting the solar module	23
Attaching the cover	23
Attaching sash arms with guide rails on the drive	24
Attaching guide rails to the sash	24
Cutting the coupling rod to size and mounting it	25
Crimped metal ribbon (only when express hinges are used)	26
<b>3 Commissioning</b>	
Activating the motor	28
Programming the end positions	28
Checking the running direction	29
Changing the running direction	29
Reset end positions	30
<b>4 Operation</b>	
Opening and closing	32
Ventilation position	32
Obstacle recognition and protection against freezing in place	32
Thermal control	33
Emergency mode	33
Additional wireless hand-held transmitters	34
Replace the battery	34
Troubleshooting	35

## Explanation of signs and symbols

### Warning notes

 <b>DANGER</b>
▶ Designates an immediately pending danger that could lead to death or severe injuries if the respective precautionary measures are not implemented.

 <b>WARNING</b>
▶ Means that death, severe bodily injury or major property damage could occur if the respective precautionary measures are not implemented.

 <b>CAUTION</b>
▶ Means a possibly pending danger that could lead to minor injuries or property damage if it is not avoided.

- ▶ Directives for action

## Safety notes

- ▶ Only qualified specialist personnel may carry out installation and commissioning!

 <b>WARNING</b>
<b>Incorrect installation could lead to severe injuries and/or damage to property.</b>
▶ Follow all installation instructions

 <b>WARNING</b>
▶ Take into account the following notes and warnings in order to avoid dangers and to protect the product.

- ▶ Observe the accident prevention regulations of the Accident Prevention & Insurance Association.
- ▶ Observe the rules of the road during transport.
- ▶ Make sure that the load is well-secured on the means of transport.
- ▶ Take care to ensure that the drives are stored under dry conditions prior to final installation and commissioning.
- ▶ Cordon off a generously large area around the installation site.
- ▶ Observe without limitation the regulations of the manufacturers of dowel and fitting materials.
- ▶ The mounting bases of the installation site are to be checked for load-bearing capacity prior to installation.
- ▶ In the event of uncertainties about the mounting bases, contact your responsible building experts.
- ▶ Electrical work may be carried out only by authorised electricians.

- ▶ The specified connection diagrams are to be observed, as otherwise damage to the motor could occur. EHRET GmbH assumes no liability for damage resulting from incorrect installation.
- ▶ Check the product for damage prior to installation. Products requiring repair may not be used.
- ▶ Do not touch any internal parts of the product that become exposed as the result of damage (e.g. electrical cables/lines).
- ▶ Discontinue operation of your electrical drive at once in the event of smoke or fumes.
- ▶ Do not allow children to play with the operating apparatus of the drives.
- ▶ Electrical/electronic devices are not secure against failure. Make sure that no hazardous situations for personnel or product could arise in the event of a power failure.
- ▶ Devices with electrical controls could go into motion at any time and without warning. Prevent situations hazardous to personnel and product that arise from this fact.
- ▶ Do not use the motor if the guide pulley is not fitted into the rail.
- ▶ Do not engage the lock when the motor is operating.
- ▶ No personnel or obstacles are permitted to be within the range of pivoting and/or travelling shutters while they are moving. Keep personnel and objects away until the shutters have reached their final position.
- ▶ Do not reach into moving parts or closing areas while shutters are opening or closing.
- ▶ Make sure that no articles of clothing or body parts are able to be caught by moving parts in the system.
- ▶ Disconnect the drives from the power supply during maintenance work.
- ▶ Ice could form on the product in the event of snowfall, sleet or icy rain. Do not operate equipment until the ice formation is no longer present, and switch automatic controls to manual.
- ▶ Make sure that the shutters are locked before any wind load occurs.
- ▶ The shutters may not be operated at wind speeds from 62 km/h (stormy wind).
- ▶ No additional loads such as persons or objects are permitted to have an effect on the shutters.
- ▶ Shutters are not intended to protect individuals from falls.

**⚠ WARNING**

**Danger of injury from the weight of the product!**

- ▶ Due to the weight of the products, transport and installation must be carried out by at least two individuals.

- ▶ Transport the product carefully in order to avoid damage.
- ▶ Take care to ensure that the product is not damaged when the packaging material is removed.

**⚠ WARNING**

**Danger of suffocation from packaging foil.**

- ▶ The packaging foil must be kept out of reach of children.
- ▶ Store the foil carefully until you turn it in for recycling.

- ▶ Turn the packaging materials in for recycling.

## CE EC Declaration of Conformity

**The manufacturer:** EHRET GmbH  
Aluminium shutters  
Bahnhofstrasse 14-18  
77972 Mahlberg, Germany

declares that the product: **EHRET window shutter drive VOLETRONIC Solar with wireless remote control**

to which this guideline refers is in conformance with the stipulations of

**Directive 2006/42/EC** Machinery Directive  
**Directive 2014/53/EC** Radio Equipment Directive  
**Directive 2014/35/EC** Low Voltage Directive

as well as with the following standards:

- EN 301489-1 V1.9.2: 2011** Radio equipment and services – Common technical requirements
- EN 301489-3 V1.6.1: 2013** Electromagnetic compatibility and Radio spectrum Matters (ERM)
- EN 55014-1: 2006 + A1 + A2** Transient emissions: Household appliances – and measurement of discontinuous interferences (clicking)
- EN 61000-3-2: 2014** Electromagnetic Compatibility (EMC) - Part 3-2: Limits – Limits for harmonic current emissions
- EN 61000-3-3: 2013** Electromagnetic Compatibility (EMC) - Part 3-3: Limits – Limitation of voltage changes, voltage fluctuations and flicker in public low-voltage supply systems, for equipment with rated current  $\leq 16$  A per phase and not subject to conditional connection
- EN 300220-2 V3.1.1: 2017** Electromagnetic compatibility and Radio spectrum Matters (ERM) - Short Range Devices (SRD) - Radio equipment to be used in the 25 MHz to 1000 MHz frequency range with power levels ranging up to 500 mW - Part 2: Harmonized EN covering essential requirements under Article 3.2 of the R&TTE Directive

## CE EC Declaration of Conformity

EN 60335-1: 2012  
+ A11: 2014

Safety of household and similar electrical appliances - Part 1

EN 60335-2-97: 2006  
+ A11: 2008 + A2: 2010  
+ A12: 2015

Safety of household and similar electrical appliances - Part 2-97:  
Particular requirements for drives for rolling shutters, awnings,  
blinds and similar equipment

EN 62233: 2008

Measurement methods for electromagnetic fields of household  
appliances and similar apparatus with regard to human exposure

EN 62479: 2010

Assessment of the compliance of low power electronic and  
electrical equipment with the basic restrictions related to human  
exposure to electromagnetic fields (10 MHz to 300 GHz)

EN 55022: 2010

Information technology equipment - Radio disturbance charac-  
teristics - Limits and methods of measurement

—

Name and address of the individual who is authorised to assemble the technical documentation:

Ralf Gielen  
Head of Technology

Location: 77972 Mahlberg, Germany  
Date: 01.01.2020



EHRET GmbH  
Eberhard Schopferer  
Management

## Installation FAQs

### Which parts have been delivered?

- Window shutter VOLETRONIC Solar
- 1× wireless hand-held transmitter
- Depending on the diagram, 1× or 2× guide rail and carriage arm
- 1× adhesive buffer, 1× stop buffer, 2× support for stop buffer per sash
- 2× shaft seal ring
- Coupling set for multiple-section window shutters

### Which means of attachment are being used?

- The fitting materials are not included in the scope of delivery!
- The selection of the fitting materials is based on the mounting bases on hand, the load-bearing capacities of which are to be checked before the installation. Observe without limitation the regulations of the manufacturers of dowel and fitting materials.



#### WARNING

**Danger of injury/property damage caused by unsuitable fitting materials**

- ▶ The fitting materials are to be selected in accordance with the load-bearing capacity of the mounting bases.

### How is the VOLETRONIC Solar window shutter drive mounted?

- First, the installation profile is aligned and mounted and the drive modules are hooked into place and attached.
- Then the carriage arms, guide rails and the stop buffer are mounted, during which the drive is connected and put into operation and the priority of the sashes is checked at the same time that the carriage arms are installed.
- Afterwards, the coupling rod is cut to size and mounted in the case of multiple-section sashes, and, if express hinges are used, then these are secured.

## Low-voltage instructions



#### CAUTION

##### Product damage due to improper installation

The drive is supplied with the voltage that is generated by the photovoltaic cell and stored in the battery via a connection cable. Damaging the cable can cause the drive to malfunction.

- ▶ Only trained specialists are permitted to carry out the installation.

#### NOTES

- Please note that this product includes Class III motors and therefore must be supplied with extra-low voltage according to the product designation. In addition, the motors must be powered only by the supplied photovoltaic cell.
- The batteries in the motor must only be replaced by qualified persons.

## Disposal



### IMPORTANT

#### Disposal

- The following information must be strictly adhered to in order to prevent any environmental damage. Even if the machine is disposed of by certified experts, the operator must ensure proper execution!



### IMPORTANT

#### Disposal

- ▶ Dispose of all machine parts in accordance with the applicable legal conditions in order to prevent the possibility of any harm to human health or the environment.

Some materials are reusable. By recycling some parts or raw materials from used products, you make an important contribution to protecting the environment.

- ▶ Please contact your local authorities if you require information about collection points near you.

### Hazardous waste

Reusable material	Components
Electronic waste	<ul style="list-style-type: none"> <li>• Electrical supplies</li> <li>• Controls</li> <li>• Circuit boards with electronic components</li> <li>• Photovoltaic cell</li> </ul>

### Recyclable materials

Reusable material	Components
Aluminium	<ul style="list-style-type: none"> <li>• Window shutters</li> <li>• Drive housing</li> <li>• Coupling</li> <li>• Guide rail</li> <li>• Fittings</li> </ul>
Copper	<ul style="list-style-type: none"> <li>• Cables</li> <li>• Motor</li> </ul>
Plastic, rubber, PVC	<ul style="list-style-type: none"> <li>• Guides</li> <li>• Accessories</li> <li>• Seals</li> <li>• Cables</li> </ul>
Steel	<ul style="list-style-type: none"> <li>• Motor and components</li> <li>• Coupling</li> <li>• Carriage arm</li> <li>• Fittings</li> <li>• Accessories</li> </ul>

# 1 Product description

## Product properties

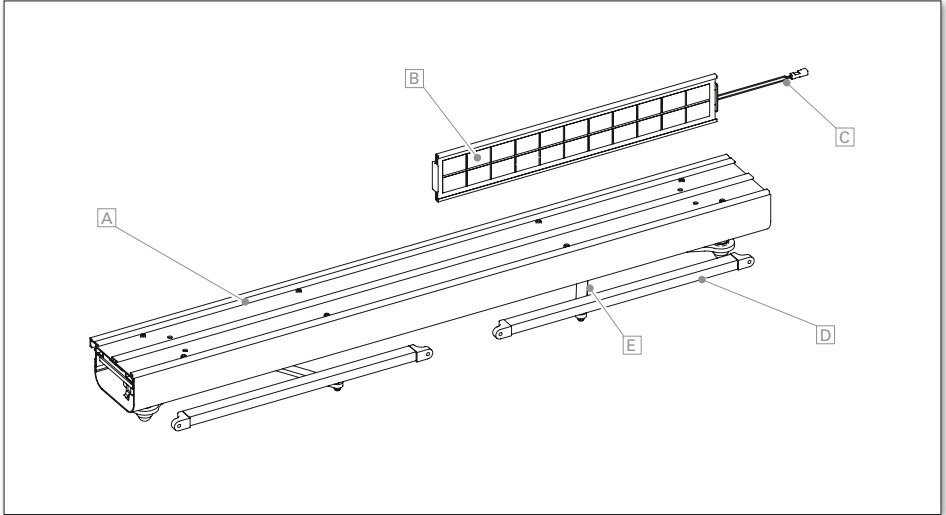

### Product description

VOLETRONIC Solar is a solar drive system for max. 2 sashes per side, for actuation of window shutters, completely pre-assembled in 2-part aluminium housing 121 × 66 mm

### Legend

- A** Drive housing incl. drive module on each stop side
- B** Solar panel consisting of a photovoltaic cell and fastening frame
- C** Solar panel connection cable, 4-point terminal
- D** Window-shutter guide rail
- E** Carriage arm

## Technical data

<b>Specified voltage</b>	5.6 V; Direct current	<b>Nom. torque</b>	30 Nm per motor
<b>Drive housing</b>	121 × 66 mm (W×H);	<b>Speed</b>	2.0 rpm
<b>Length according to specifications:</b>		<b>Connection cable</b>	0.6 m, 2-wire; 3.0 m (optional)
with 1 motor	336 – 1600 mm	<b>Power consumption</b>	3.6 W
with 2 motors	571 – 2500 mm	<b>Disconnection</b>	Load switch-off
<b>Solar panel</b>	460 × 75 × 17 mm (W×H×D)	<b>Protection class</b>	III
<b>Average volume A</b>	LpA ≤ 70 dB(A)	<b>Degree of protection</b>	IP 24
<b>Sash weight per stop side</b>	max. 50 kg		

### Pre-programming

VOLETRONIC Solar shutter drives are pre-programmed and delivered fully charged. The following settings are pre-programmed at the drive prior to delivery:

- The wireless hand-held transmitter is calibrated for the drive and marked with the corresponding position number.
- The direction of rotation of the sashes is configured.
- The sash priority is configured.
- Up to four additional remote controls can be taught-in on one drive (main transmitter, additional transmitter, timer, iDiamant home control).
- A half-open position, the “ventilation position”, is pre-programmed at the factory and is switched on using the comfort button.

### NOTES

- As the motors correspond to Protection class III, they must be supplied with extra-low voltage and powered only by the photovoltaic cell supplied.
- The functionality is maintained on the photovoltaic cell for up to 30 days without direct sunlight.
- Collision protection of the sash sides: in case of double-sided schemes, the opposite drive side does not open/close until the first drive side has completed its opening/closing movement.
- Do not use the motor if the guide pulley is not fitted into the rail.
- Do not engage the lock when the motor is operating.

## Scope of delivery

### Voletronic Solar

Motorisation for window shutters

#### Variant A

Header installation

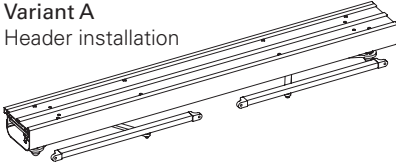

#### Variant B

Reveal installation  
on the side

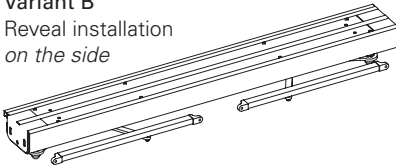

#### Variant C

At the bottom  
above the windowsill

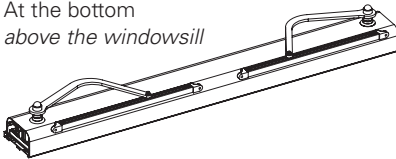

**INFO** Fastening material at the installation site (for all variants)

### Solar module

contained in the scope of delivery

Photovoltaic cell

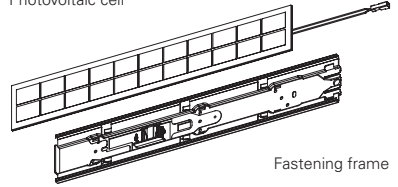

Fastening frame

### Accessories per sash

1x with 1L/1R, 2L/2R; 2x with 2, 3L/3R, 4

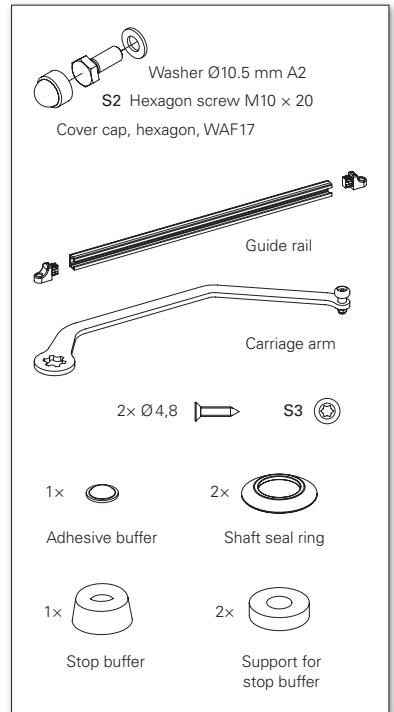

## Coupling with multiple-section sashes

Diagram 2L/2R, 3L/3R, 4

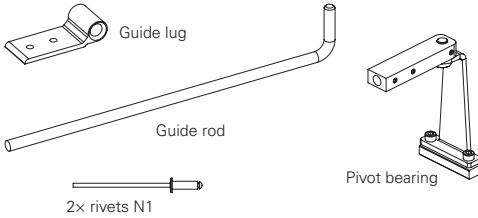

## Operation



6632 Main transmitter, 1 channel (included in the scope of delivery)



6603 additional handheld transmitter, 1 channel (optional)



6634 replacement main transmitter, 1 channel (optional)

## Options

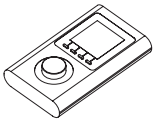

6632 Timer

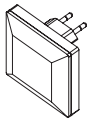

6633 iDiamant, building control system module



6631 Extension cable 3 m



6220 Support for drive end piece, pair  
To be used with window shutter models with protruding slats

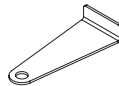

6360 Cover remover  
For simplified subsequent dismantling of the cover

1x (1L/1R, 2L/2R); 2x (2, 3L/3R, 4);

2x Ø 4,8 x 32 mm S4

## Tools required

not included in the scope of delivery

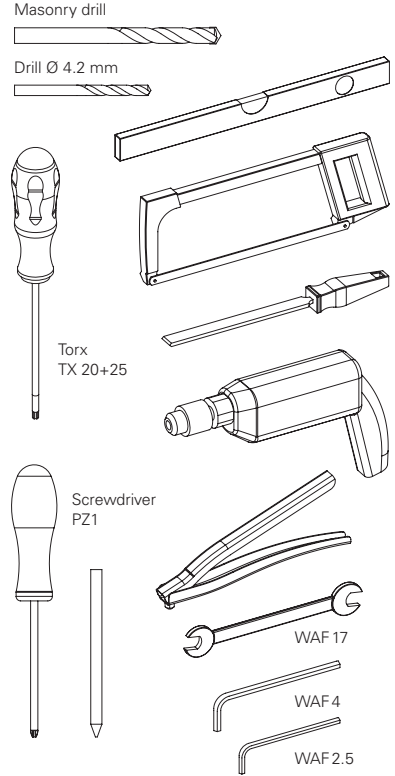

## 2 Installation instructions

### Preparation

#### NOTES

Before installing the VOLETRONIC Solar window shutter drive, the window shutter must be able to open and close without difficulty.

- ▶ Existing manual locking elements (e.g. shutter bolt or espagnolette) can still be used (during holidays, for example), but must be unlocked before electrical operation.

#### Dismantling the cover and drive modules

- ▶ ① Remove the cover **A**.
- ▶ ② Undo the 4 drive screws **B**.
- ▶ ③ Shift the drive modules **C** towards the interior and remove from the installation profile **D**.

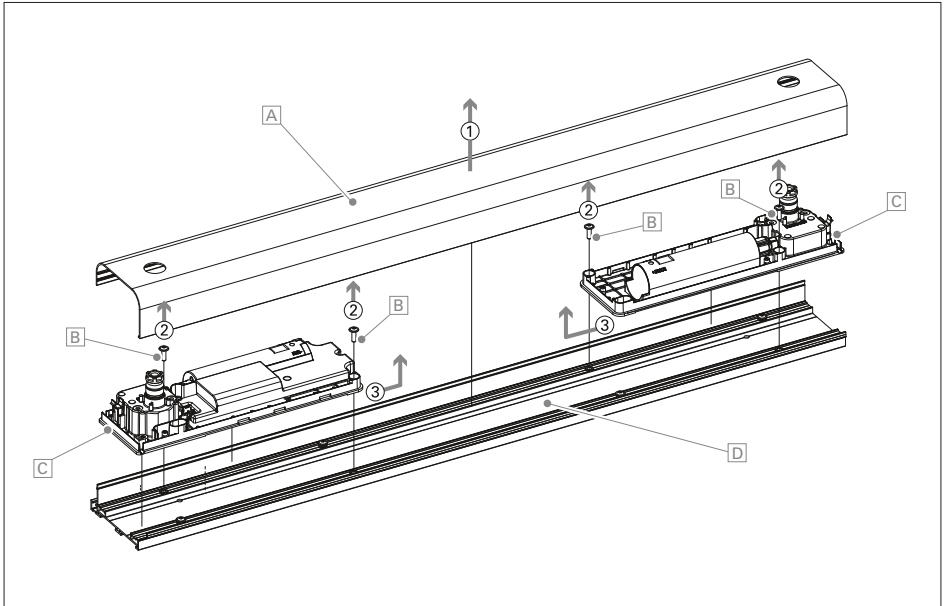

## Mounting the installation profile and fastening the drive modules

---

### **⚠ WARNING**

**Danger of injury/property damage caused by unsuitable fastening materials**

- ▶ Select the fastening material in accordance with the load capacity of the installation substrates!

---

### **NOTES**

- The selection of the fastening method is dependent on the base and is therefore exclusively your own responsibility.
- Note that the lintel must be horizontal in both width and depth.
- The dowels used must be able to withstand a force of at least 40 kg. The brackets must be fastened at at least two points.
- EHRET recommends the use of screws with a diameter of at least 6 mm.
- The drive should be installed within 9 months.

## Variant A

### Header installation

- ▶ Position the installation profile with shutters closed (dimension  $X + 5$  mm) and align it horizontally.

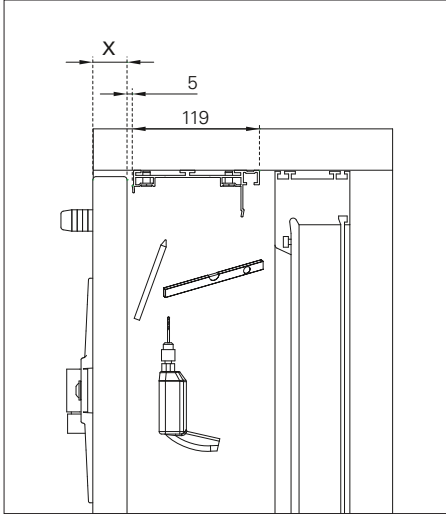

X = sash thickness in the reveal

- ▶ Mark and drill the fastening holes
- ▶ Fasten installation profile at at least four points

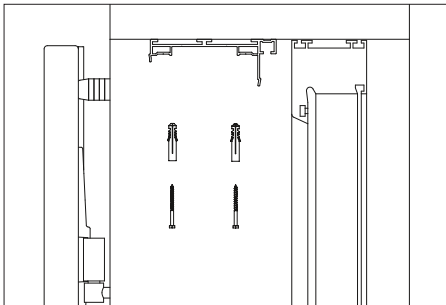

- ▶ Hook the drive modules into the installation profile and fasten with the drive screws.

*Do not screw the drive screws too tightly!*

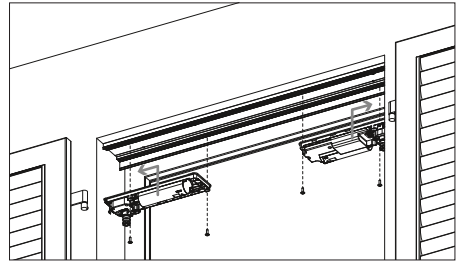

### For multiple-section sashes

*Diagram 2L/2R, 3L/3R, 4*

- ▶ Insert the spacer  into the drive housing when coupling multi-section sashes!

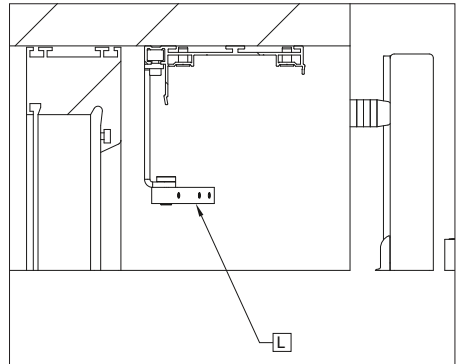

 Pivot bearing

## Variant B

### Reveal installation

- ▶ Position the installation profile with lateral fastening brackets (dimension X + 5 mm).
- ▶ Align it vertically and horizontally with a spirit level.
- ▶ Mark and drill slots in the middle, then fasten the brackets.

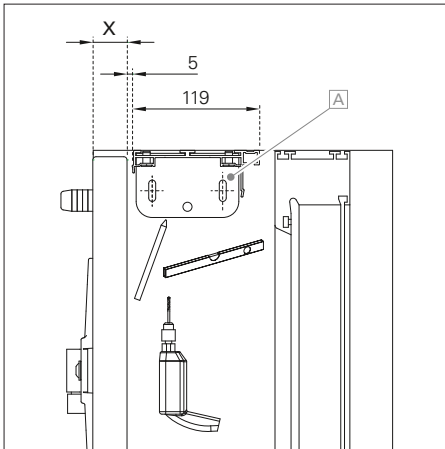

X = sash thickness in the reveal

A Fastening bracket

### ⚠ CAUTION

Property damage caused by sliding of the drive due to insufficient fastening

- ▶ Use security bore hole!

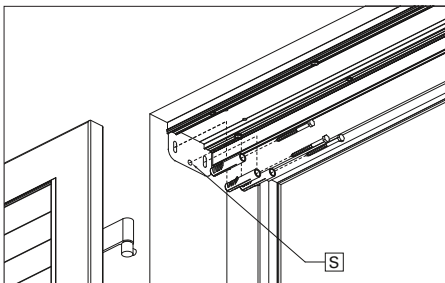

S Security bore hole

- ▶ Hook the drive modules into the installation profile and fasten with the drive screws.

*Do not screw the drive screws too tightly!*

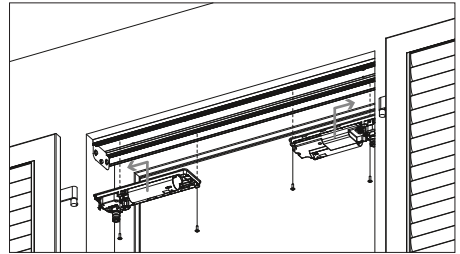

### For multiple-section sashes

*Diagram 2L/2R, 3L/3R, 4*

- ▶ Insert the spacer L into the drive housing when coupling multi-section sashes!

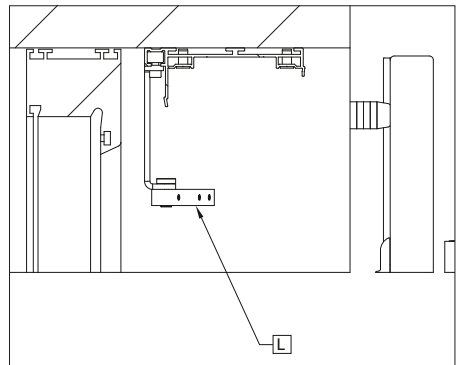

L Pivot bearing

## Variant C

Installed at the bottom above the windowsill

- ▶ Position the installation profile with lateral fastening brackets (dimension X + 5 mm).
- ▶ Align it vertically and horizontally with a spirit level.
- ▶ Mark and drill slots in the middle, then fasten the brackets.

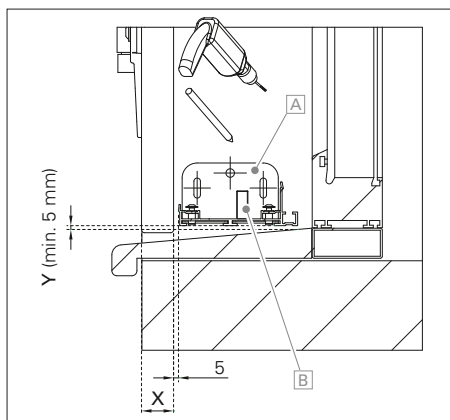

X = sash thickness in the reveal

Y = air min. 5 mm (upper edge of windowsill to lower edge of installation profile)

**A** Fastening bracket

**B** Spirit level

### ⚠ CAUTION

Property damage caused by sliding of the drive due to insufficient fastening

- ▶ Use security bore hole!

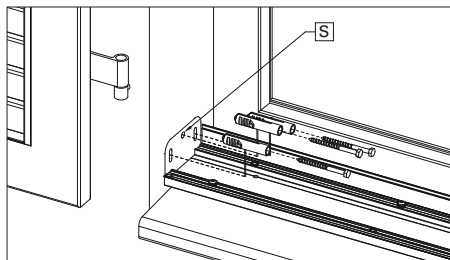

**S** Security bore hole

- ▶ Hook the drive modules into the installation profile and fasten with the drive screws.

### NOTE

Do not screw the drive screws too tightly!

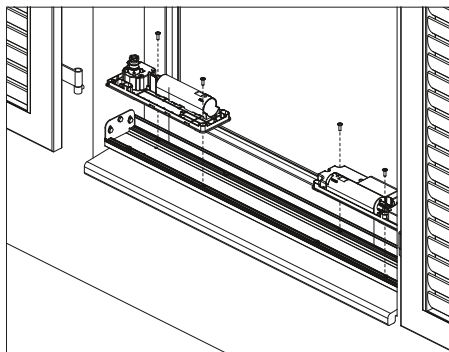

### For multiple-section sashes

Diagram 2L/2R, 3L/3R, 4

- ▶ Insert the spacer **L** into the drive housing when coupling multi-section sashes!

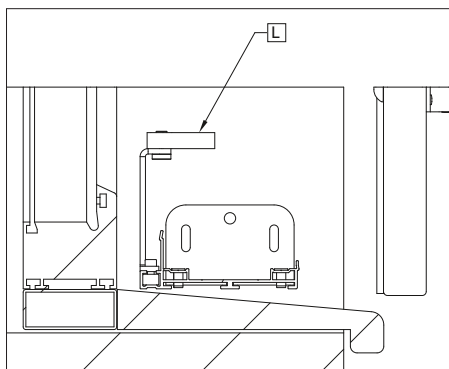

**L** Pivot bearing

## Wiring the drive modules

### ⚠ CAUTION

#### Malfunctioning due to cable damage

▶ Do not cut off or crush the cable in the interior of the product!

- ▶ Connect the connection cable **A** to the photovoltaic cell connection **C** (*4-point terminal*) of the main module **1**.
- ▶ Loosen the cable fastening **E** and lay the connection cable **A** towards the output (see drawing).
- ▶ Tighten the cable fastening **E** with the screwdriver.
- ▶ Connect the connection cable **B** to the secondary module connection **D** (*3-point terminal*).
- ▶ Lay the connection cable **B** towards the secondary module **2** (see drawing).
- ▶ Connect the connection cable **B** to ⊕ (*red*) and ⊖ (*black*) of the secondary module **2**.
- ▶ Stow the excess connection cable length **B** in the secondary module using the fastening clip.

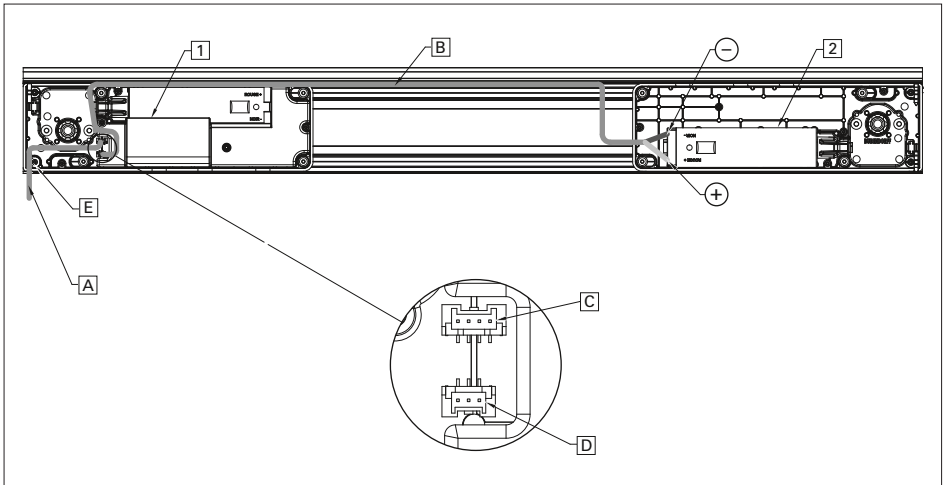

- A** Connection cable (length 0.6 m) between the main module and photovoltaic cell
- B** Connection cable (length 3 m) between the main module and secondary module
- C** Photovoltaic cell connection, 4-point terminal, cable length: 0.6 m
- D** Secondary module connection, 3-point terminal, cable length: 3 m
- E** Cable fastening, can be screwed

- 1** Main module
- 2** Secondary module

## Installation instructions solar panel

### NOTES

Follow all instructions so that the corresponding power is generated, the solar concept energy balance does not fall below zero and the battery does not drain. This could otherwise lead to loss of function, but is nonetheless not a technical defect.

- For optimal operation, the solar panel must be able to receive direct lighting.
- It should neither be fixed inside the house nor covered by objects (glazing, shutters, balconies,...).
- In locations with heavy snow cover, the solar panel must be positioned vertically on the façade.
- It is imperative that all installation regulations are complied with. If they are not complied with, the warranty will be excluded.
- If the conditions cannot be complied with, the solar panel can be ordered on a 3-metre cable.

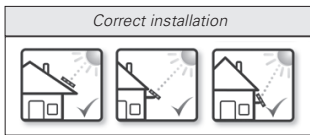

### Detached house

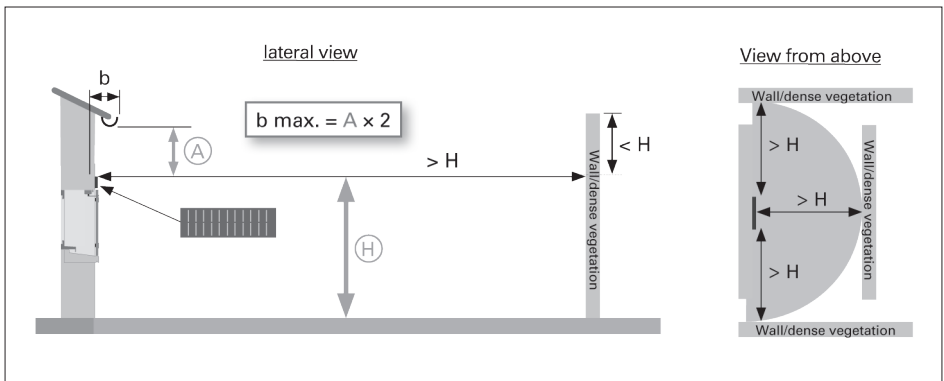

(A) = Height from upper side of photovoltaic cell

(H) = height / distance to be respected in relation to the external ground and not to an constructed terrace.

## Apartment block

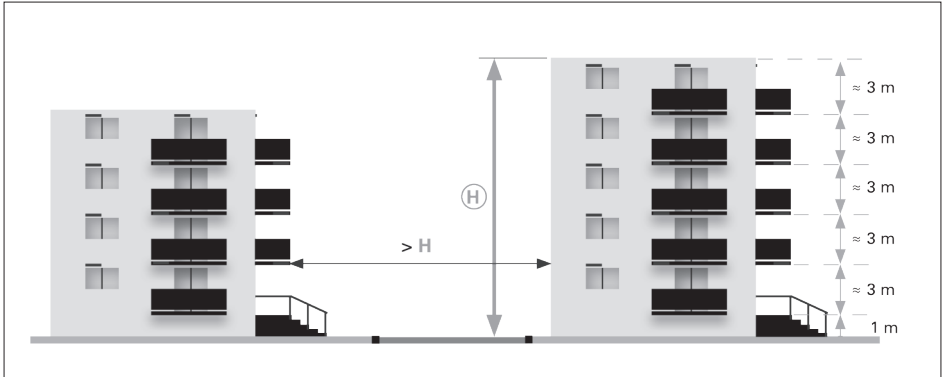

$H$  = height / distance to be respected in relation to the external ground and not to an constructed terrace.

## Installation instructions solar cell on 3m cable

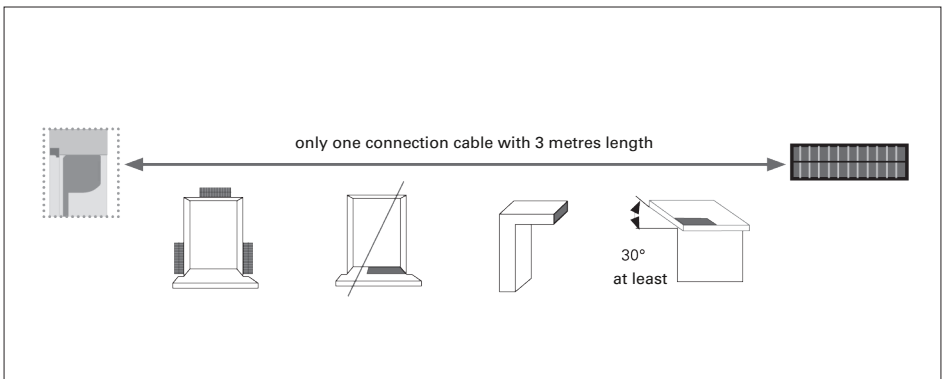

## Fastening the solar module

### **⚠ WARNING**

**Danger of injury and property damage caused by unsuitable fitting materials**

- ▶ Select the fitting material in accordance with the load capacity of the mounting bases!

### NOTES

- The selection of the fastening method is dependent on the base and is therefore exclusively your own responsibility.
- The installation material is not included in the scope of delivery.
- Note that the drive must be installed parallel and at a right angle in the reveal to ensure that the window shutters work perfectly.

- ▶ Position the fastening frame of the solar module with the cable exit on the outside.
- ▶ Mark, drill and fasten the fastening points **B**.

*EHRET recommends maintaining a horizontal distance of 95 or 303 mm between the fastening points **B** and a vertical distance of 50 mm to the edge of the reveal.*

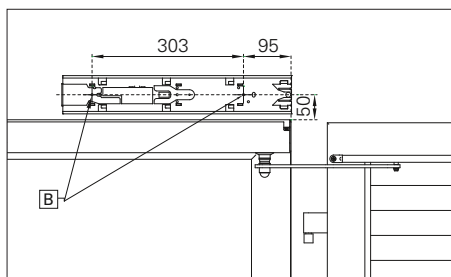

- ▶ Allow the end of the photovoltaic cell plug to protrude.

## Connecting the side cover

- ▶ Detach the side cover **D** of the solar module from the fastening frame at the predetermined breaking **S** point.

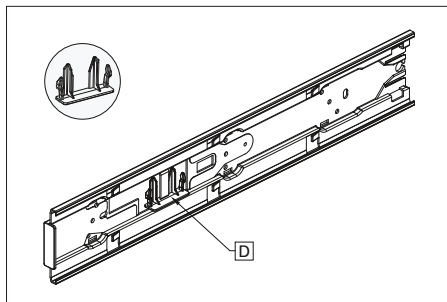

*Side cover detail*

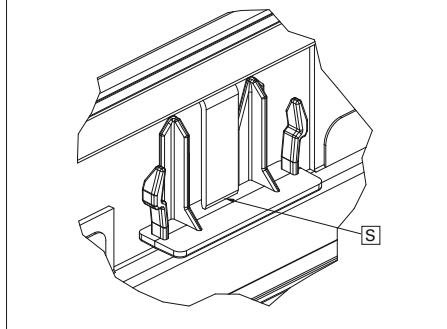

- ▶ Push the side cover **D** sideways into the fastening frame and snap it into place.

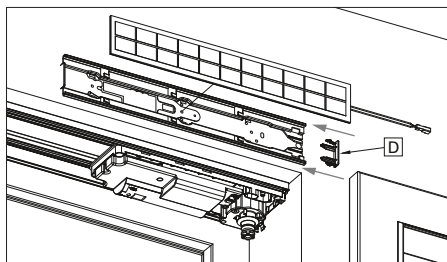

## Connecting the solar module

- ▶ Connect the drive connection cable to the solar module plug.

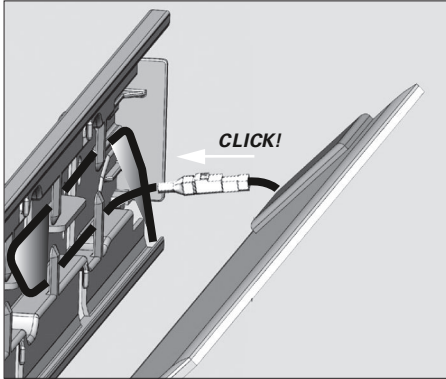

- ▶ Stow the excess cable length behind the frame.

**IMPORTANT:** The connection plug must be fixed inside the solar module and must not hang out of it!

- ▶ Install the solar module.

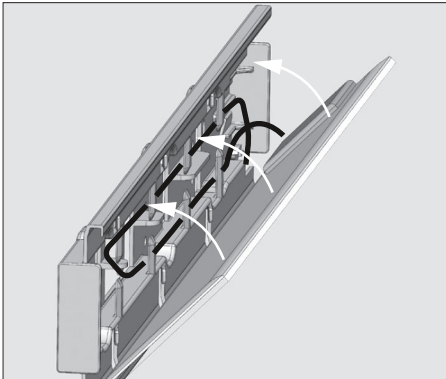

## Attaching the cover

### ⚠ CAUTION

#### Malfunctioning due to cable damage

- ▶ Position the notching of the cover on the side with the PV cable!
- ▶ Protect the PV cable against crushing by the cover of the drive housing!

- ▶ Hold the cover parallel and clip it firmly in place.
- ▶ Push the shaft seal rings **D** over the drive shaft until they engage in the groove **N**.
- ▶ Attach the **K** adhesive buffers.

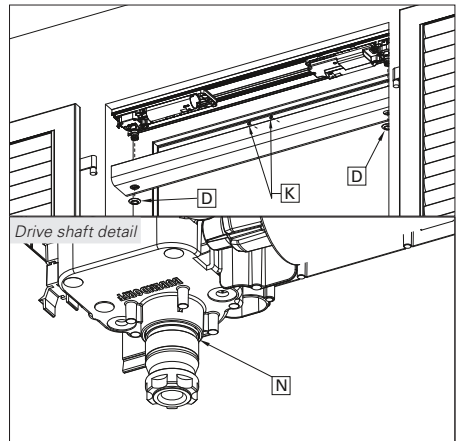

## Attaching sash arms with guide rails on the drive

### NOTES

Note whether a left-hand or right-hand sash arm is required.

The castor of the sash arm must be positioned at the middle of the guide rail at the time of installation.

The joints of the guide rails must face downwards at the time of installation.

- ▶ Thread the sash arm into the guide rail.
- ▶ Fit the end pieces onto the guide rail.

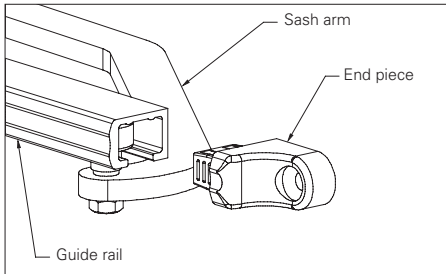

- ▶ Set the sash arm onto the drive shaft.
- ▶ Fasten the sash arm with the self-locking S2 screw and washers supplied.
- ▶ Set the cover cap on the S2 screw.

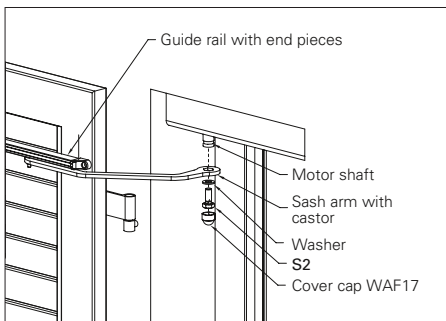

## Attaching guide rails to the sash

### NOTES

Observe the edge clearance of the guide rails with rabbet or surface-mounted installation.

For models with protruding slats, use the 6220 supports for the window shutter drive end pieces with the corresponding S4 screws.

When selecting screws for window shutters made of wood (a decision that is the exclusive responsibility of the installer), care must be taken to ensure that the sliding guides cannot be torn off.

- ▶ Centre the guide rail in the sash width and use a spirit level to align it horizontally.
- ▶ Mark fastening holes, drill them with a  $\varnothing 4.2$  mm drill bit and fasten them with the S3 screws supplied.

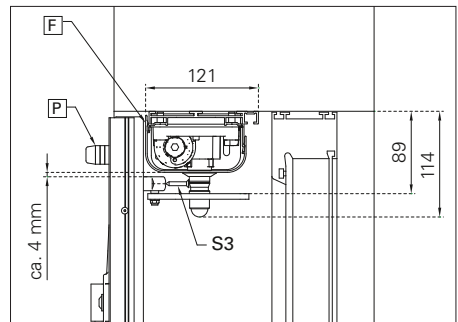

- [F] Adhesive buffer
- [P] Stop buffer with support

- ▶ Install stop buffers [P] as sash stops.

*The stop buffers can be installed as stops either on the exterior side of the sash at the top-outer corner or on the façade.*

## Cutting the coupling rod to size and mounting it

For multiple-section sashes  
Diagram 2L/2R, 3L/3R, 4

### NOTES

Observe the edge clearance of the guide lug with rabbet or surface-mounted installation!

- ▶ Mount the guide lug [2] with N1 rivets.

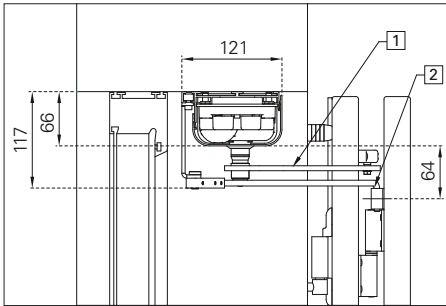

- [1] Sash arm
- [2] Guide lug

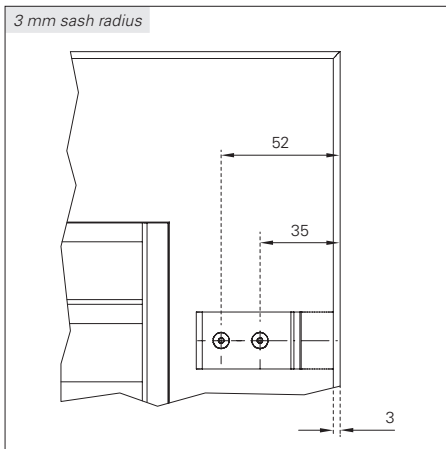

- ▶ Close the double shutter and mark the centre of rotation of guide lug B. Afterwards, open the double shutter and measure the distance from A to B.

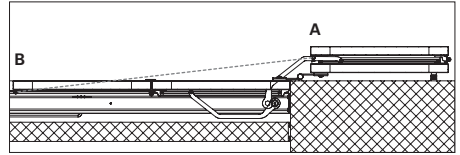

- ▶ Close the double shutter and divide the distance determined (from A to B) in half. Inscribe the half path on the motor housing C as shown in the drawing.

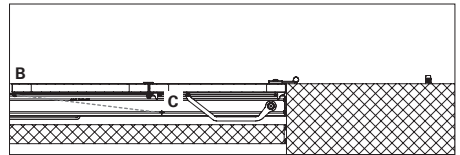

- ▶ Open the double shutter once again and, as shown in the drawing, the half path (from A to B) is marked once again on motor housing D. The centre of rotation E of the coupling rod lies between the two points C and D.

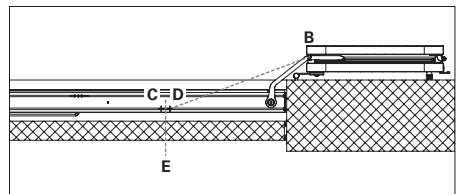

- ▶ Connect the pivot bearing [3] in the spacer using the axis bolts and lock it in place with a locking set screw [4].
- ▶ Cut the coupling rod to size.
- ▶ Hook the guide rod [5] in the guide lug [2], slide the pivot bearing [3] on and lock in place with the u2 locking set screws [4] in the pivot bearing [3].

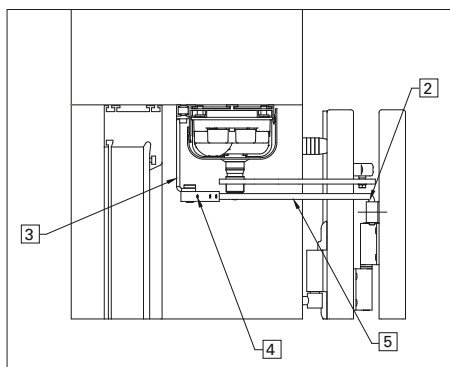

- [2] Guide lug
- [3] Pivot bearing
- [4] Locking set screw
- [5] Guide rod

## Crimped metal ribbon

*only when express hinges are used*

### NOTES

The express hinges used must be secured against shifting in place as follows after the installation of the VOLETRONIC window shutter drive:

- ▶ Close and align the shutters and stabilise them with wooden wedges in the reveal.
- ▶ Remove hinge holders.
- ▶ Mark, drill and countersink rivet holes.
- ▶ Attach rivets so they are flush and reinstall hinge holders.

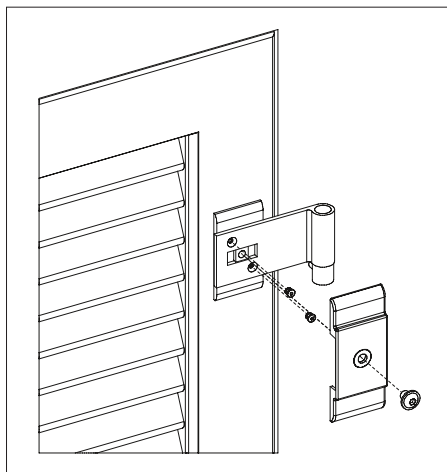



### 3 Commissioning

#### Activating the motor

**NOTES**

No adjustment of the end positions is required for the VOLETRONIC Solar drive.

Make sure that the solar module is connected to the drive module!

If there are any unusual noises, lubricate the castor in the interior of the guide rail.

- ▶ Press and hold the  button for more than 4 sec.

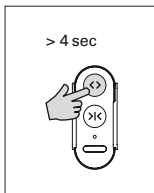

The window shutter automatically opens completely until it reaches the stops and then closes again completely.

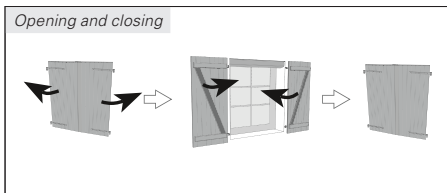

The motor transport mode is finished.

The motor is activated.

#### Programming the end positions

- ▶ Press the  button

The drive confirms with a sudden opening movement during start-up.

*Wait until the window shutter is completely open!*

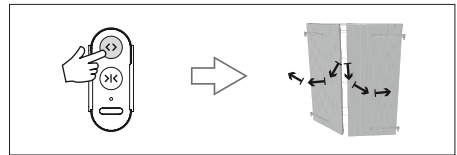

- ▶ Press the  button

The drive confirms with a sudden closing movement during start-up.

*Wait until the window shutter is completely closed!*

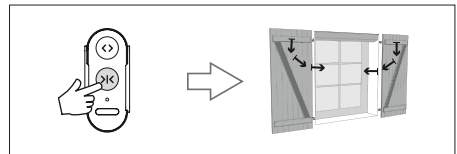

- ▶ Press the  button again

The drive confirms with a smooth run-up without a sudden movement during start-up and brakes gently when reaching the end positions.

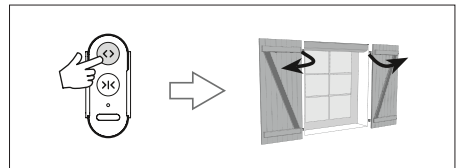

The end positions are programmed

## Checking the running direction

- ▶ Press the  button.

The window shutter opens evenly without a sudden movement and brakes gently when reaching the end positions.

*Wait until the window shutter is completely open!*

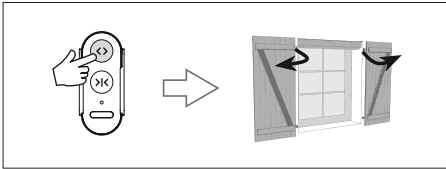

- ▶ Press the  button on the wireless hand-held transmitter

The window shutter closes completely.

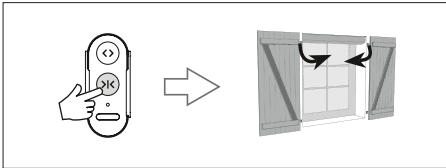

### IMPORTANT!

The *OPEN* and *CLOSE* buttons have been transposed.

- ▶ The running direction must be changed (see  chapter "Changing the running direction", p. 26).

*One sash opens while the other one closes.*

- ▶ Check whether the connection cable between the drive modules is connected correctly (see  chapter "Wiring the drive modules", p. 19).

## Changing the running direction

*if necessary*

### NOTES

This step is necessary when the alignment of the sashes is reversed. The leading sash is the sash with the cover strip.

### Prepare to change the running direction

- ▶ Open the remote control with a screwdriver

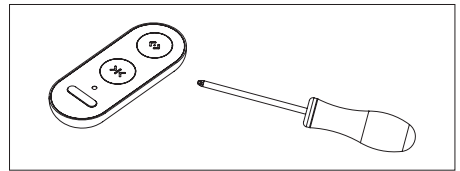

- ▶ Remove the battery and wait 3 seconds
- ▶ Reinsert the battery
- ▶ Press the remote control until the folding shutter reacts (press 2 or 3 times)

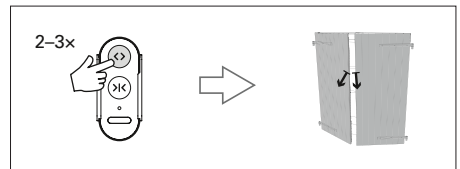

- ▶ Stop the window shutter

### Program the change of running direction

**IMPORTANT!**

The following describes how the direction change is programmed. Read through the entire process to internalize it before executing it.

- Make sure that you perform the following button combinations **without stopping and very quickly!**

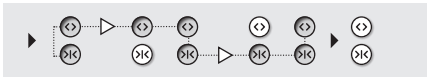

- During the entire process, both buttons must never be released at the same time, otherwise the programming will be aborted.

- ▶ Press and hold **⊖+⊕** at the same time
  - ▷ Release **⊕** briefly (approx. 1 sec.) and press it again immediately
  - ▷ Release **⊖** briefly (approx. 1 sec.) and press it again immediately
- ▶ Release **⊖+⊕**

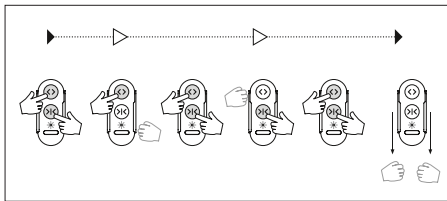

The LED lights up **red**. The drive confirms by OPENING and CLOSING the window shutter.

The running direction is changed.

### Reset end positions

*if necessary*

- ▶ Press the **⊖**, **⊕** and **⇐** button and hold it down for more than 4 seconds.

The drive confirms with a sudden opening/closing movement.

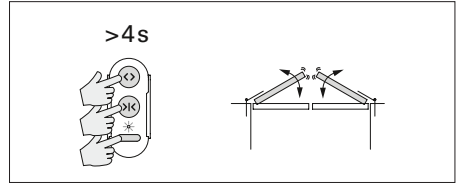

- ▶ Hold down the **⇐** button for more than 4 seconds.

The drive confirms with a sudden OPENING movement.

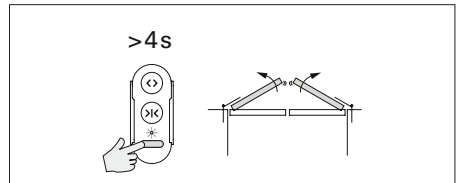

The end positions are reset.

- ▶ Repeat the commissioning procedure from Chapter "Teaching in the end positions" on page 25.



## 4 Operation

### Opening and closing

- ▶ Press the  button *briefly*.

The window shutter opens and stops automatically at normal speed when it reaches the stops.

- ▶ Press the  button *briefly*.

The window shutter is closed completely at normal speed.

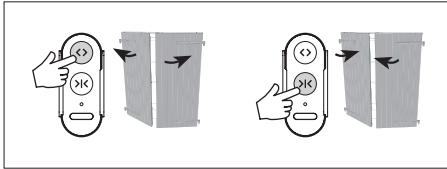

- ▶ Press and hold the  button *for more than 2 sec.*

The window shutter opens and stops automatically at a reduced speed when it reaches the stops.

- ▶ Press and hold the  button *for more than 2 sec.*

The window shutter is closed completely at a reduced speed.

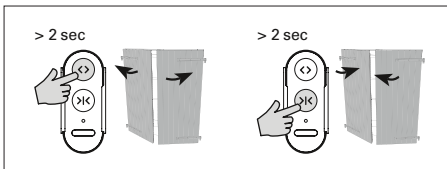

### Ventilation position

- ▶ Press the  button briefly.

The window shutter moves into a predefined *ventilation position*. The LED lights up red.

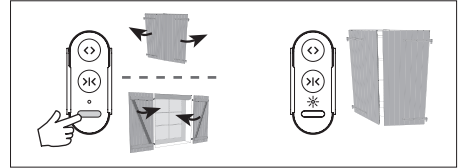

### Changing the ventilation position

- ▶ Stop shutter in the desired position
- ▶ Hold down the  button for more than 6 seconds

*The drive confirms with a sudden opening/closing movement.*

### Obstacle recognition and protection against freezing in place

#### NOTES

The automatic obstacle recognition protects the VOLETRONIC Solar against damage and prevents accidents.

If a sash encounters an obstacle, strong wind or gusts of wind while opening or closing, the shutter will be stopped automatically.

The protection against freezing in place functions just like the recognition of obstacles: The drive is stopped automatically as soon as it detects resistance.

## Thermal control

### NOTES

The automatic control is pre-installed at the factory. Additional equipment is not required.

In automatic mode, each shutter controls its own movements depending on the solar radiation and the temperatures to which it is exposed.

- **Summer mode:** The window shutters close automatically when there is maximum solar radiation and intense heat. They open again when the temperature is cooler.
- **Winter mode:** To maintain the heat in your home, the automatic control unit closes your window shutters as night falls when the average temperature falls below 12° C.

### Activating summer/winter mode

- ▶ Press and hold the  button for more than 2 sec.

The thermal control is activated. The LED switches from red to **green**.

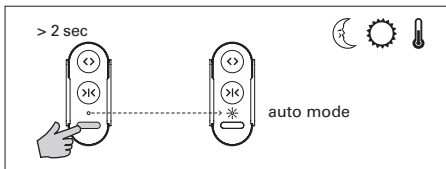

### Deactivating summer/winter mode

- ▶ Press and hold the  button again for more than 2 sec.

The thermal control is deactivated. The LED switches from green to **red**.

## Emergency mode

### NOTES

In normal operation, the operation of the shutters is automatically stopped by the obstacle recognition system in strong winds and gusts of wind.

- By switching to emergency mode, the shutters can be forced to open or close once.
- The user can activate the emergency mode via the main transmitter, but must permanently monitor the shutter.
- When the movement is complete, the shutter returns to normal operation.

### Forced opening

- ▶ Press the  and  button on the main transmitter simultaneously.

*The shutters open despite strong wind.*

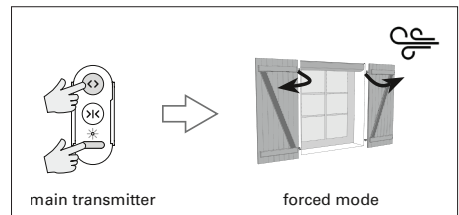

### Forced closing

- ▶ Press the  and  button on the main transmitter simultaneously.

*The shutters close despite strong wind.*

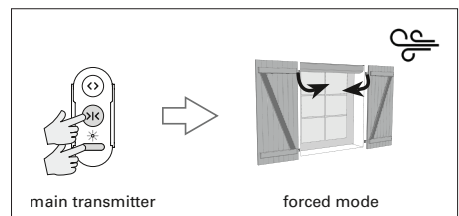

## Additional hand-held transmitters

*optional*

### NOTES

The scope of delivery includes a wireless hand-held transmitter for controlling the EHRET VOLETRONIC Solar window shutter drive.

1-channel wireless handheld transmitter with holder

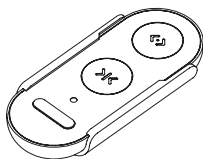

6603 Additional handheld transmitter

6634 Replacement main transmitter

### Additional handheld transmitter

- Using an additional wireless handheld transmitter, it is possible to control a group of several (max. 30) solar window shutter drives.
- The LED of an additional handheld transmitter lights up orange.
- For the programming of the additional handheld transmitter, please refer to the operating instructions supplied with the handheld transmitter.

### Replacement main transmitter

- When reordering the replacement main transmitter (e.g. in case of loss or damage) the serial number of the drive must be indicated. This can be found on the drive modules and on the packaging of the handheld transmitter.
- The LED of the replacement main transmitter lights up red

## Replace the battery

*in the transmitter*

- ▶ Open the housing with a screwdriver

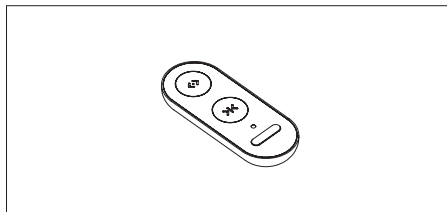

- ▶ Replace battery (ref. CR2032)



- ▶ Close the housing



## Troubleshooting

Problem	Possible cause(s)	Solution(s)
Drive is mounted but does not run	The drive is not receiving current	▶ Check connection to the photovoltaic cell
	Transport mode is still activated	▶ Switch off transport mode
The drive jerks once when opening	The end positions are not taught-in	▶ Teach-in end positions
The drive jerks 3 times when closing, 2 confirmations when opening	Photovoltaic cell is not connected	▶ Check connection to the photovoltaic cell
The drive jerks 3 times when closing, gives 3 confirmations when opening	Photovoltaic cell is not connected and battery is weak	▶ Teach-in end positions
The drive jerks 3 times when closing, gives 4 confirmations when opening and runs slowly	Photovoltaic cell is not connected and battery is weak	▶ Check the position of the photovoltaic cell
	Outdoor temperature is below -15°C	▶ Provide for stronger solar radiation
Shutter opening is activated and stopped again immediately	Opening is blocked by the bolt	▶ Open the bolt
	The direction of rotation has not been set	▶ Direction of rotation must be changed
Shutter opening (e.g. diagram 2) is activated and only one sash is opened or is blocked by the other sash	The wiring to the mechanical module has not been established.	▶ Check connection to the mechanical module
The direction of rotation is set, but the direction of rotation of the sash with T-bar is reversed	The red/black wires are reversed	▶ Connect the wiring to the mechanical module correctly
The drive was in operation for a long time, but it no longer works	The battery has become weak due to low solar radiation	▶ Check the position of the solar panel ▶ Provide for stronger solar radiation
The window shutter does not close/open completely	Window shutter fitted incorrectly	▶ Check whether the window shutter moves freely and without resistance
	Obstacle in the way	▶ Remove the obstacle
	The end positions are not taught-in correctly	▶ Reset settings and teach-in end positions again
Window shutters are opened when close button is pressed	The main module is located on the right side of the drive, direction of rotation is not set	▶ Direction of rotation must be changed
The window shutter goes too far when closing	End stops missing	▶ Check whether there is a window shutter end stop present at the top and bottom
Changing the direction of rotation does not work	The programming steps are performed too slowly	▶ Perform the programming steps reasonably quickly
The wireless transmitter is not working	The battery of the wireless transmitter is dead	▶ Change the battery of the wireless transmitter. ▶ Please be sure to recycle used batteries.

## **EHRET GmbH**

Aluminium shutters

Bahnhofstrasse 14-18

77972 Mahlberg, Germany

Tel. + 49 (0) 78 22/439-0

Fax + 49 (0) 78 22/439-116

[www.ehret.com](http://www.ehret.com)