



MoveOn

Electric folding sliding shutter



Installation and operating instructions

INSTALLATION
SPECIALIST PERSONNEL
Valid from 05.2016

E 671.3

Notes

These installation and operating instructions describe the installation and commissioning of the EHRET MoveOn electric folding sliding shutter.

Carefully read through these installation instructions prior to commissioning. Observe the specified process steps and take into account the notes and recommendations given. Knowledge of and technically impeccable implementation of the given safety notes and warnings are prerequisites for safe and proper operation of the EHRET MoveOn. Insufficient knowledge at the time of commissioning and utilisation lead to the loss of any liability claims against EHRET GmbH.

These installation instructions are a component part of the product and are therefore always to be retained until the product is disposed of. These installation instructions are to be passed along in the event of the sale of this product.

These installation instructions are addressed to qualified specialist personnel. Qualified specialist personnel are persons who are familiar with the transport, set-up, installation, commissioning and operation of the product and who have appropriate qualifications for their work. Specialist personnel must know and observe the relevant standards and/or guidelines.

This product complies with the general rules of technology. Safety-conscious behaviour is necessary for commissioning the product safely. For this reason, observe the following notes.

Should any of the information in these installation instructions not be absolutely clear, it is essential that you contact the specialist personnel at EHRET GmbH, 77972 Mahlberg (Germany).

Contents

Notes	2
Explanation of signs and symbols	4
Safety notes	4
CE EC Declaration of Conformity	6
1 Product description	
Product properties	7
Technical data	7
Scope of delivery	8
Tools required	9
MoveOn with installation frame	10
2 Installation instructions	
Assembling the installation frame	11
Pre-installation guide rail	12
Securing the installation frame in the reveal	13
Fastening the guide rails to the installation frame	13
Mounting the substructure and top guide rail	14
Mounting the wall panels	14
Mounting the bottom guide rail	15
Mounting the cover panel	16
Hanging sash 1	16
Mounting the coupling profile on the outside	17
Mounting the coupling profile on the outside	19
Mounting the top and bottom carriages	20
Mounting the locking plate	20
Mounting the cover panel	21
3 Operating instructions	
MoveOn connections	22
Commissioning	24
Checking the direction of rotation	24
Performing a learning run	25
Master transmitter teaching	25
Teaching an additional transmitter	26
Clearing an additional transmitter	27
Clearing all additional transmitters	27

Explanation of signs and symbols

Warning notes

 **DANGER**

▶ Designates an immediately pending danger that could lead to death or severe injuries if the respective precautionary measures are not implemented.

 **WARNING**

▶ Means that death, severe bodily injury or major property damage could occur if the respective precautionary measures are not implemented.

 **CAUTION**

▶ Means a possibly pending danger that could lead to minor injuries or property damage if it is not avoided.

- ▶ Directives for action

Safety notes

- ▶ Only qualified specialist personnel may carry out installation and commissioning!

 **WARNING**

Incorrect installation could lead to severe injuries and/or damage to property.

- ▶ Follow all installation instructions.

 **WARNING**

- ▶ Take into account the following notes and warnings in order to avoid dangers and to protect the product.

- ▶ Observe the accident prevention regulations of the Accident Prevention & Insurance Association.
- ▶ Observe the rules of the road during transport.
- ▶ Make sure that the load is well-secured on the means of transport.
- ▶ Take care to ensure that the drives are stored under dry conditions prior to final installation and commissioning.
- ▶ Cordon off a generously large area around the installation site.
- ▶ Observe without limitation the regulations of the manufacturers of dowel and fitting materials.
- ▶ The mounting bases of the installation site are to be checked for load-bearing capacity prior to installation.
- ▶ In the event of uncertainties about the mounting bases, contact your responsible building experts.
- ▶ Electrical work may be carried out only by authorised electricians.

- ▶ The specified connection diagrams are to be observed, as otherwise damage to the motor could occur. EHRET GmbH assumes no liability for damage resulting from incorrect installation.
- ▶ Check the product for damage prior to installation. Products requiring repair may not be used.
- ▶ Do not touch any internal parts of the product that become exposed as the result of damage (e.g. electrical cables/lines).
- ▶ Discontinue operation of your electrical drive at once in the event of smoke or fumes.
- ▶ Do not allow children to play with the operating apparatus of the drives.
- ▶ Electrical/electronic devices are not secure against failure. Make sure that no hazardous situations for personnel or product could arise in the event of a power failure.
- ▶ Devices with electrical controls could go into motion at any time and without warning. Prevent situations hazardous to personnel and product that arise from this fact.
- ▶ No personnel or obstacles are permitted to be within the range of pivoting and/or travelling shutters while they are moving. Keep personnel and objects away until the shutters have reached their final position.
- ▶ Do not reach into moving parts or closing areas while shutters are opening or closing.
- ▶ Make sure that no articles of clothing or body parts are able to be caught by moving parts in the system.
- ▶ Disconnect the drives from the power supply during maintenance work.
- ▶ Ice could form on the product in the event of snowfall, sleet or icy rain. Do not operate equipment until the ice formation is no longer present, and switch automatic controls to manual.
- ▶ Make sure that the shutters are locked before any wind load occurs.
- ▶ The shutters may not be operated at wind speeds from 62 km/h (stormy wind).
- ▶ No additional loads such as persons or objects are permitted to have an effect on the shutters.
- ▶ Shutters are not intended to protect individuals from falls.

 **WARNING**

Danger of injury from the weight of the product!

- ▶ Due to the weight of the products, transport and installation must be carried out by at least two individuals.

- ▶ Transport the product carefully in order to avoid damage.
- ▶ Take care to ensure that the product is not damaged when the packaging material is removed.

 **WARNING**

Danger of suffocation from packaging foil.

- ▶ The packaging foil must be kept out of reach of children.
- ▶ Store the foil carefully until you turn it in for recycling.

- ▶ Turn the packaging materials in for recycling.

CE EC Declaration of Conformity

The manufacturer: EHRET GmbH
Aluminium shutters
Bahnhofstrasse 14-18
77972 Mahlberg, Germany

declares that the product: **EHRET MoveOn – Electric folding sliding shutter**

to which this guideline refers is in conformance with the stipulations of

Directive 1999/05/EC Radio equipment and telecommunications terminal equipment,

as well as with the following standards:

EN 301 489-3:2000 Electromagnetic compatibility and radio spectrum matters (ERM); Electromagnetic compatibility (EMC) standard for radio equipment and services – Part 3: Specific conditions for short-range devices (SRD) operating on frequencies between 9 KHz and 40 GHz

EN 300 220-3:2000 Electromagnetic compatibility and radio spectrum matters (ERM); Short-range devices (SRD); Radio equipment to be used in the 25 MHz to 1000 MHz frequency range with power levels ranging up to 500 mW – Part 3: Harmonized EN covering essential requirements under Article 3.2 of the R&TTE Directive

98/37/EC Machinery Directive

EN 73/23/EEC Low Voltage Directive

**EN 60730 + A1 + A2
+A11 +A12 +A13
+A14 +A15** Safety requirements for automatic electric regulators and controllers

Name and address of the individual who is authorised to assemble the technical documentation:

Ralf Gielen
Head of Technology

Location: 77972 Mahlberg, Germany
Date: 01.05.2016



EHRET GmbH
Eberhard Schopferer
Management

1 Product description

Product properties

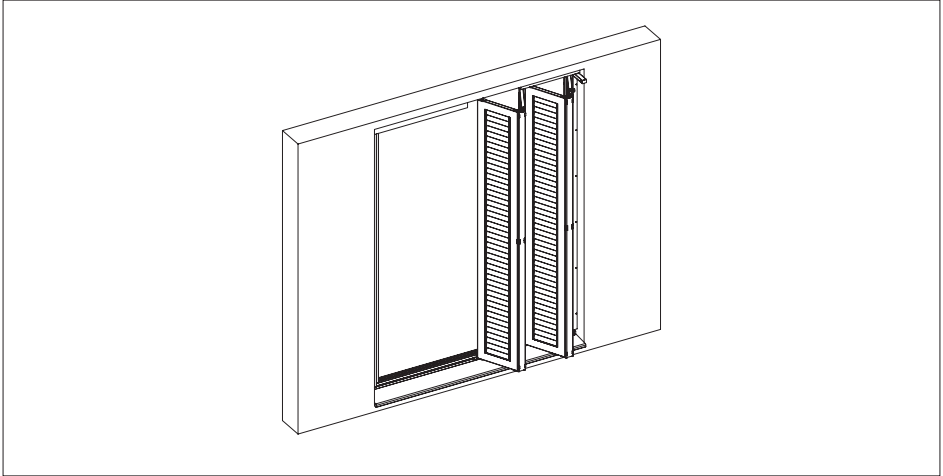

- Drive with integrated controller to activate folding sliding shutters
- Connection cable (approx. 1 m) with ferrules (included)
- Integrated cut-off relays suitable for long control lines
- Also compatible with bus system
- A serial push-button or optionally a wireless hand-held transmitter is required externally
- All motor functions can be set via the button (e.g. learning run)
- Multi-function LED with direction-of-travel indicator as adjustment aid and runtime controller

Technical data

Operating voltage	230 V	Power consumption	max. 30 W (operation) <1 W (standby)
internal	approx. 5 V and 12 V / DC	Degree of protection	IP 54
Drive housing	50 × 50 × 230 mm	Operating temperature	-10°C to +55°C
Connection cable	approx. 1 m		

Scope of delivery

MoveOn

Electric folding sliding shutter

Complete with 230 V folding sliding shutter drive, sashes with fittings and accessories

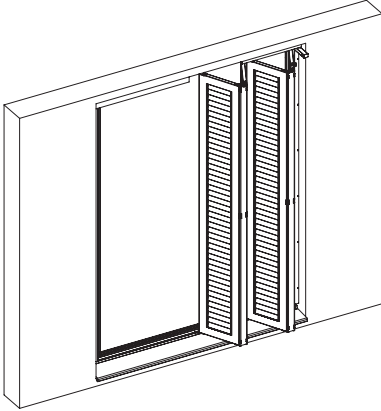

Frame accessories

Depending on 2-/4-/6-sash variant

Top guide rail, fitted

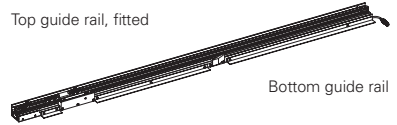

Bottom guide rail

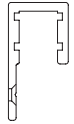

Top stop (right or left)

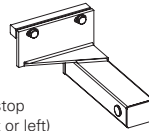

Bottom stop (right or left)

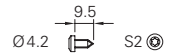
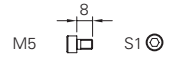

230 V folding sliding shutter drive

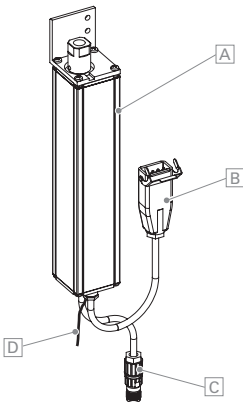

- [A] Housing, [B] Switch supply line,
- [C] Electric lock, [D] Antenna

Wall panel, motor side



Wall panel, opposite side to motor



Cover panel, motor side



Cover panel, opposite side to motor

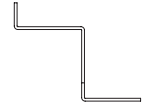

Sash accessories

Depending on 2-/4-/6-sash variant

Coupling profiles

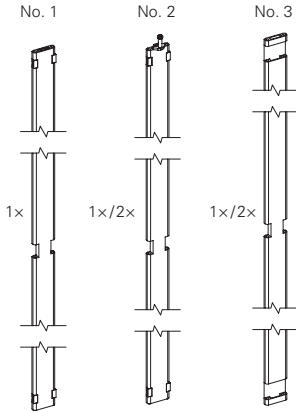

Sash with fitting

2x/4x/6x

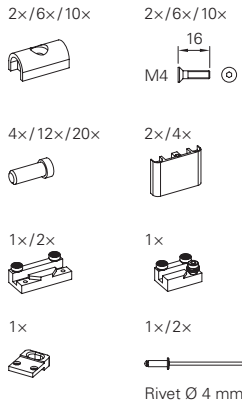
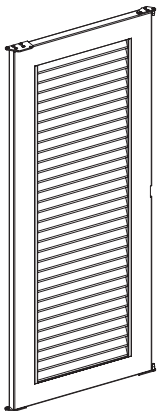

Tools required

*not included in the scope of delivery

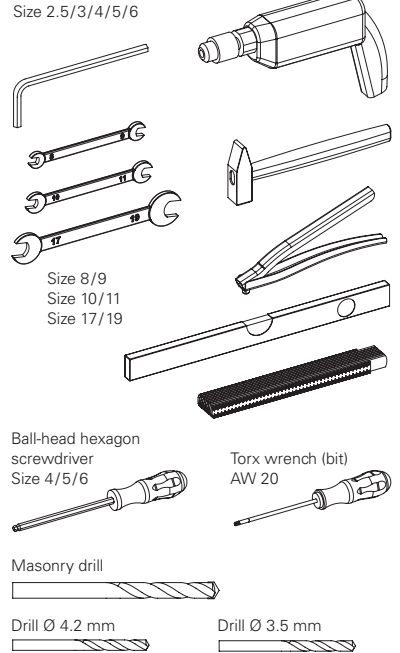

Scope of delivery

MoveOn with installation frame

Electric folding sliding shutter

Complete with installation frame, 230 V folding sliding shutter drive, sashes with fittings and accessories

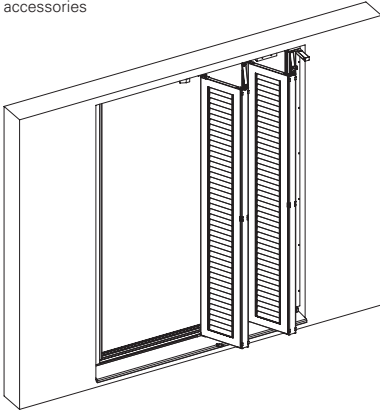

Installation frame accessories

Depending on 2-/4-/6-sash variant

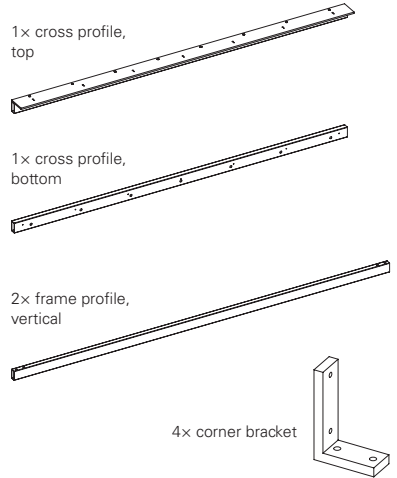

Screws for installation frame

Depending on 2- / 4- / 6-sash variant

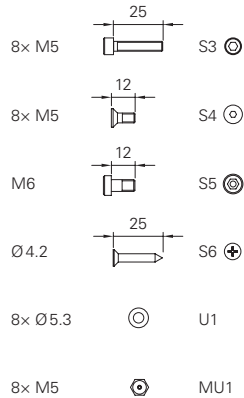

2 Installation instructions

Assembling the installation frame

*This chapter relates to the MoveOn variant **with installation frame**.*

*For information on installing the MoveOn **without an installation frame**, please go to chapter "Pre-installation of guide rail", p. 12.*

- ▶ Screw the corner brackets onto the top and bottom cross profiles using S3 SCREW, U1 WASHER and MU1 NUT

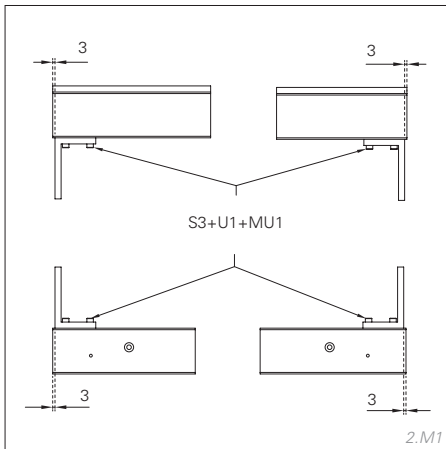

- ▶ Slide the vertical frame profiles over the corner brackets on the top and bottom cross profiles.

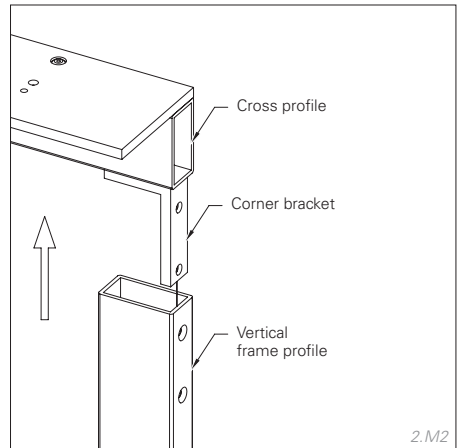

- ▶ Fasten the frame profiles with S4 SCREWS.

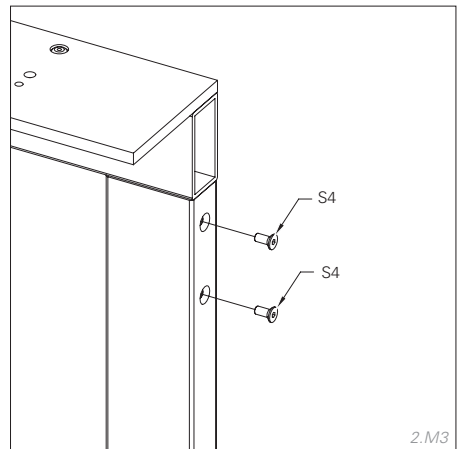

Pre-installation guide rail

Top guide rail

- ▶ Insert the motor with the mount into the return pulley and screw onto the top guide rail using S1 SCREWS.

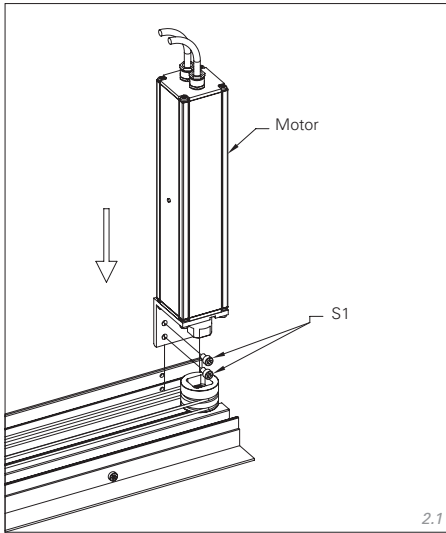

- ▶ Insert the square (14 × 14 mm) into the guide rail and use the enclosed screws and washers to fasten the top fixed stop into place.

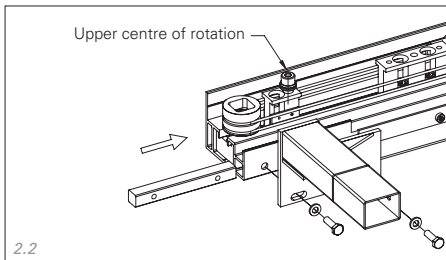

Bottom guide rail

- ▶ Insert the bottom stop into the guide rail and adjust to the dimension of the upper centre of rotation (71 mm from the outer edge of the rail).

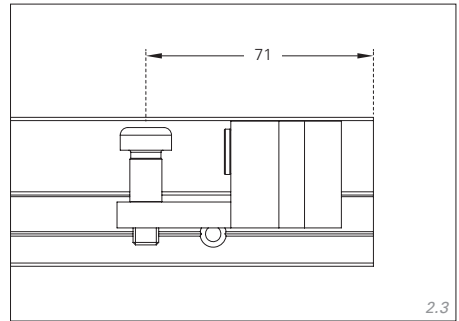

- ▶ Clamp the stop in place with the screws.

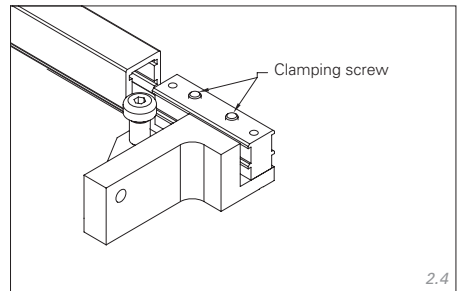

Securing the installation frame in the reveal

This chapter relates to the MoveOn variant with installation frame.

For information on installing the MoveOn **without an installation frame**, please go to  chapter "Mounting the substructure and top guide rail"; p. 14.

NOTE

The substructure must be aligned perpendicularly in both directions!

All fastening elements are to be provided by the customer and must be adapted to the substrate in question.

- ▶ Place the installation frame in the opening.
- ▶ Align the installation frame and fasten at the top.

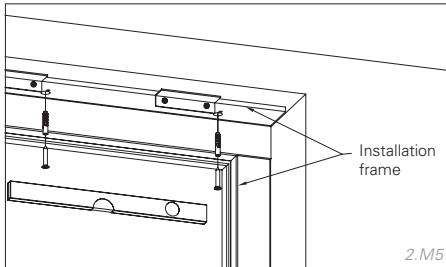

- ▶ Align the installation frame and fasten at the bottom.

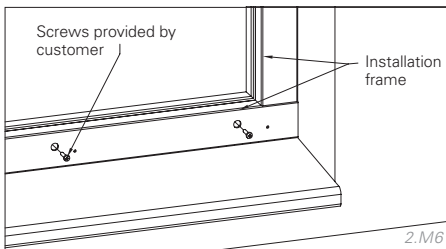

Fastening the guide rails to the installation frame

This chapter relates to the MoveOn variant with installation frame.

For information on installing the MoveOn **without an installation frame**, please go to  chapter "Mounting the substructure and top guide rail"; p. 14.

NOTE

Only Allen screws in size M6 may be used (head height)!

- ▶ Screw the top guide rail onto the installation frame.

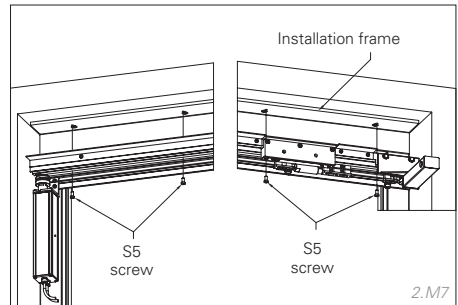

- ▶ Fasten the bottom guide rail to the installation frame in the position specified by the fastening holes.

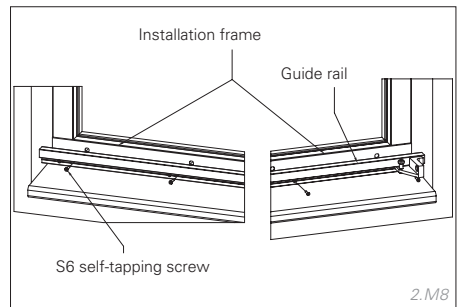

Mounting the substructure and top guide rail

NOTES

The substructure must be aligned perpendicularly in both directions!

Only Allen screws in size M6 may be used (head height)!

- ▶ Mount and align the substructure for the top guide rail.

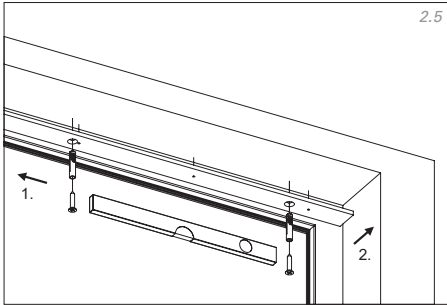

- ▶ Screw the top guide rail onto the substructure.

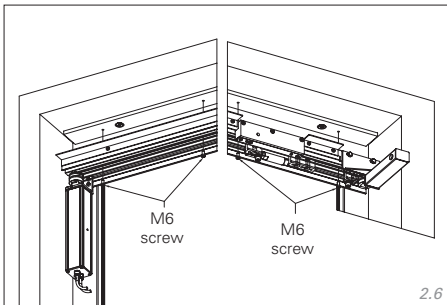

Mounting the wall panels

Opposite side to motor

- ▶ Position the wall panel so that it is laterally flush with the guide rail and in direct contact horizontally with the lower edge of the guide rail.

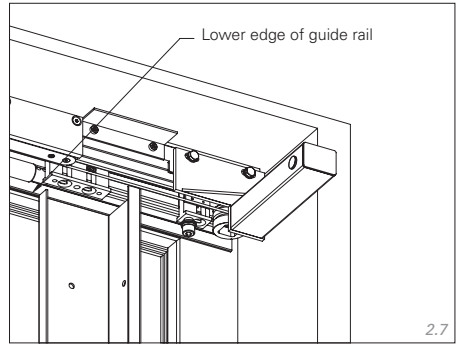

- ▶ Align the wall panel with the spirit level and fasten at the side or rear depending on the structural situation.

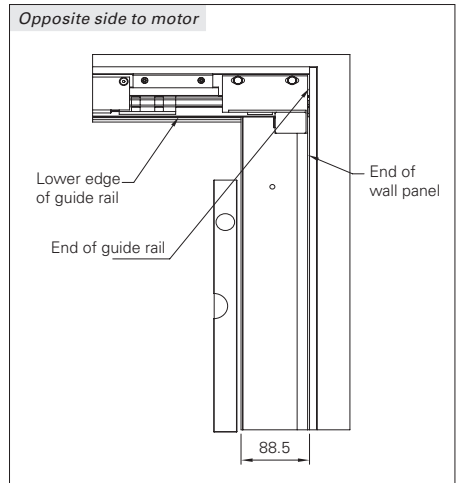

Mounting the bottom guide rail

Motor side

- ▶ Position the wall panel so that it is laterally flush with the guide rail and in direct contact horizontally with the lower edge of the guide rail.

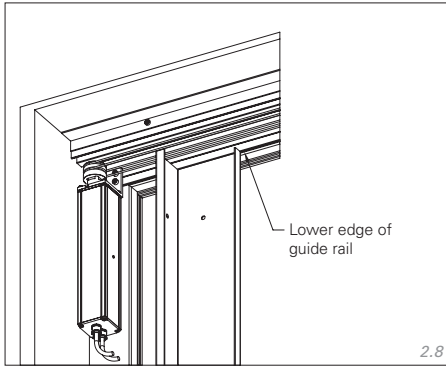

- ▶ Align the wall panel with the spirit level and fasten at the side or rear depending on the structural situation.

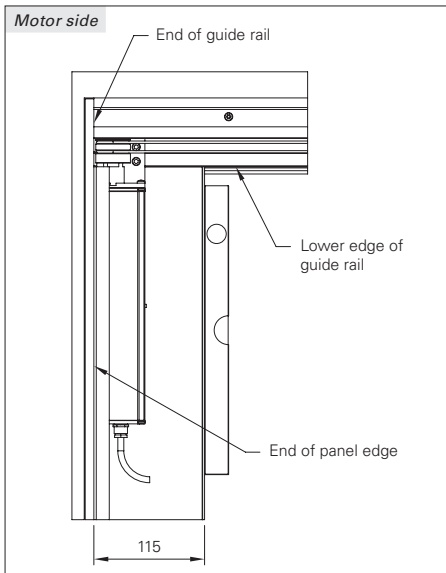

CAUTION

The head of the fastening screws must not protrude from the guide rail by more than 2 mm!

- ▶ Position the guide rail directly below the two vertical cover panels.
- ▶ Align the panel so that it is laterally flush with the cover panels and fasten on the outside on both sides.

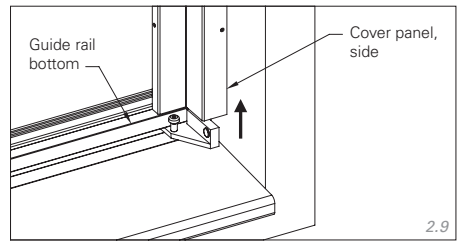

- ▶ Use a rod level to check the guide rail for sagging and finish fastening it in place.

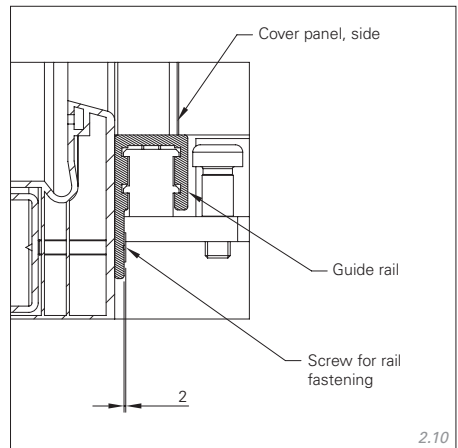

Mounting the cover panel

Opposite side to motor

- ▶ Remove the top fitting screw.

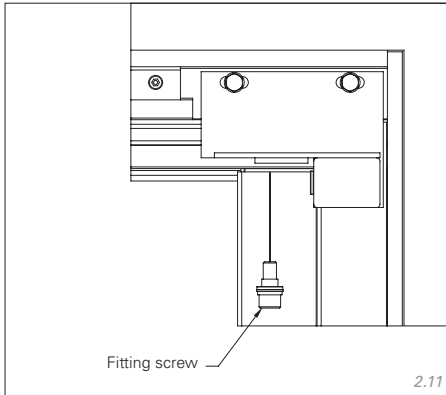

- ▶ Position the cover panel on the opposite side to the motor and fasten it with S2 SCREWS.

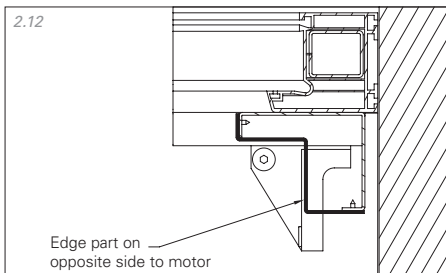

Edge part on opposite side to motor

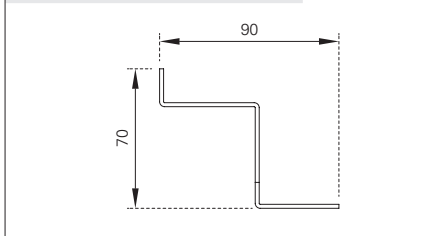

Hanging sash 1

Sash 1

- ▶ Remove the top and bottom fitting screws.
- ▶ Position the sash.
- ▶ Screw the sash into the pivot bearing with the top fitting screw.
- ▶ Screw the bottom fitting screw into the pivot bearing.

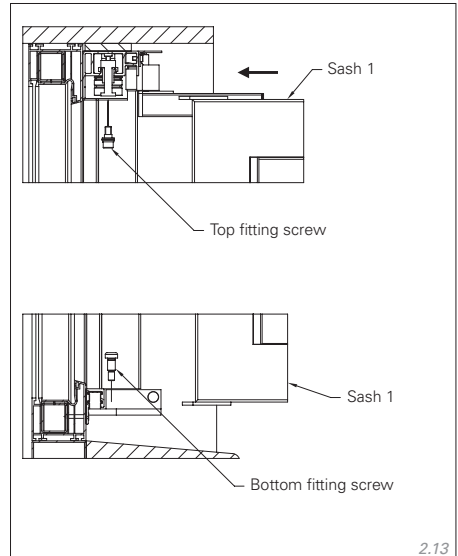

Structure of top fitting screw:

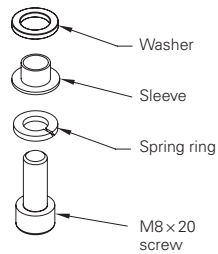

Mounting the coupling profile on the outside

Sash 1+2

- ▶ Dismantle the top fastening plates on sash 1 and sash 2.
- ▶ Bring sash 2 to the same height as sash 1.

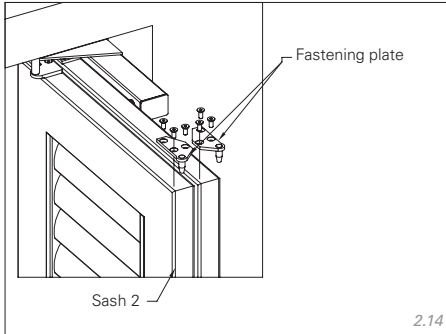

- ▶ Place the brass washers on the pins of the bottom fastening plates.

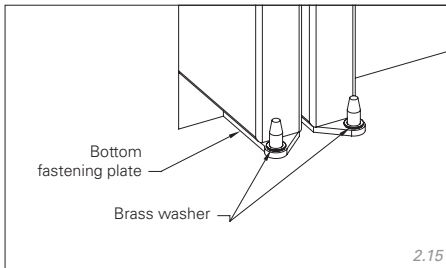

- ▶ Place coupling profile no. 1 on the fastening plates at the bottom.

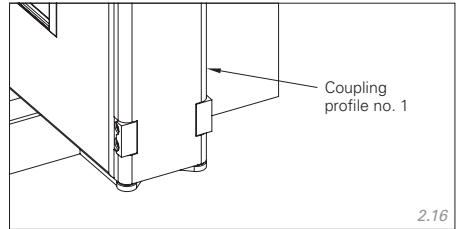

- ▶ Hang the top fastening plate on coupling profile no. 1 and screw into place.

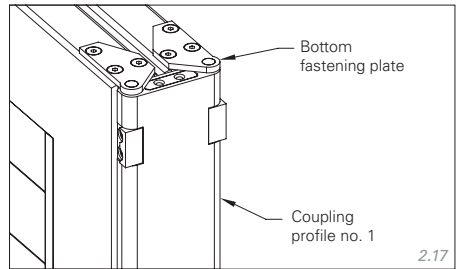

- ▶ Place the hinge pins in the hinges and seal with the cover.

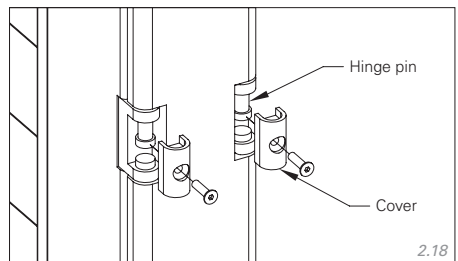

Mounting the coupling profile on the inside

Sash 3

- ▶ Bring sash 3 to the same height as sash 1 and sash 2.
- ▶ Position the carriage in front of the sashes.

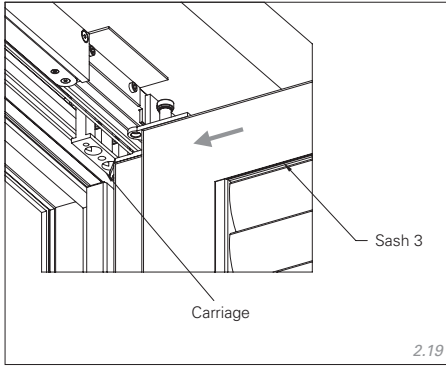

- ▶ Place coupling profile no. 3 on the hinge.

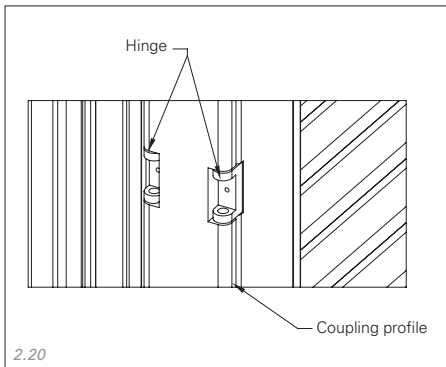

- ▶ Place the brass washer in between coupling profile no. 3 and the pivot lug.
- ▶ Insert the fitting screw through coupling profile no. 3 and screw into the carriage.

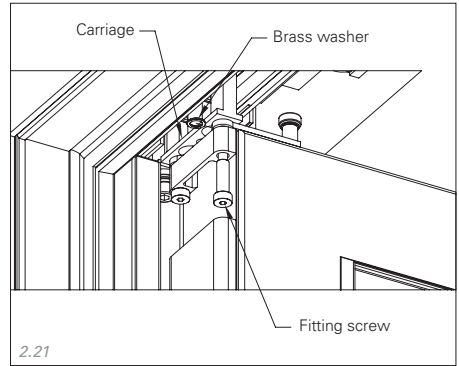

- ▶ Insert the hinge pin, place the cover on and screw into place.

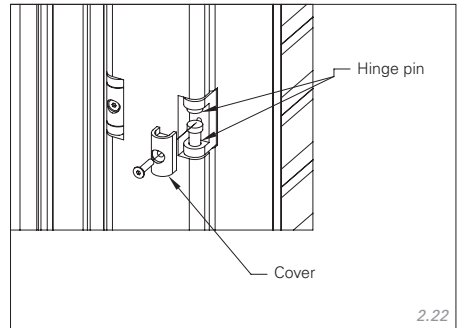

Mounting the coupling profile on the outside

- ▶ Insert the bottom carriage into the guide.
- ▶ Place the brass washer in between the carriage and the pivot lug.
- ▶ Insert the fitting screw through coupling profile no. 3 and screw into the carriage.

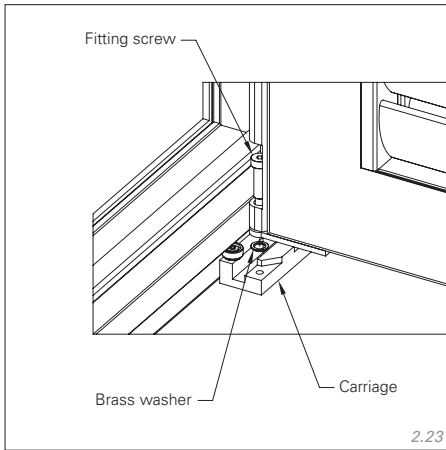

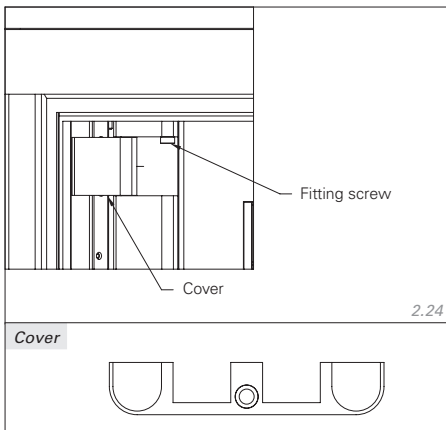

- ▶ Insert the cover for the fitting screws.

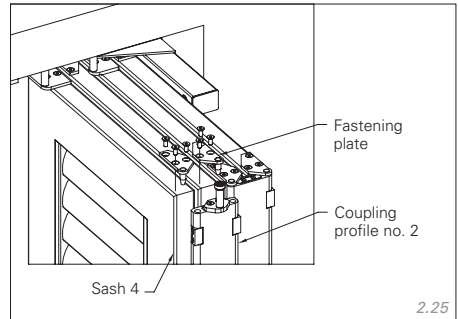

Sash 3+4

- ▶ Dismantle the top fastening plates on sash 3 and sash 4.
- ▶ Bring sash 4 to the same height as sash 3.



- ▶ Carry out the following installation steps for sashes 3+4 analogue to sashes 1+2, as described in the  chapter "Mounting the coupling profile on the outside" on page 17 (see drawings 2.15-2.18):

- ▶ Place the brass washers on the pins of the bottom fastening plates (see 2.15).
- ▶ Place coupling profile no. 2 on the fastening plates at the bottom (see 2.16).
- ▶ Hang the top fastening plate on coupling profile no. 2 and screw into place (see 2.17).
- ▶ Place the hinge pins in the hinges and seal with the cover (see 2.18).

Mounting the top and bottom carriages

- ▶ Remove the top and bottom fitting screws.
- ▶ Position sash 4/6 and the carriage.
- ▶ Screw sash 4/6 into the top carriage with the fitting screw.

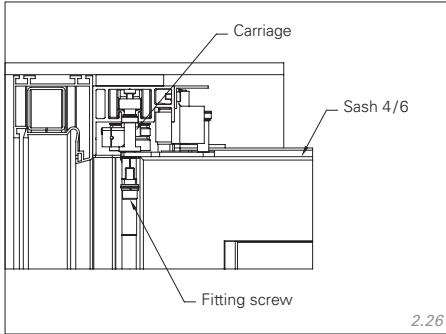

- ▶ Insert the bottom carriage into the guide.
- ▶ Screw sash 4/6 into the carriage with the fitting screw.

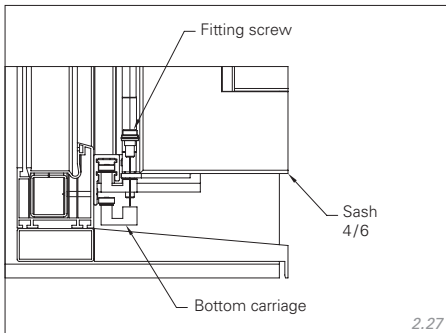

Structure of top fitting screw:

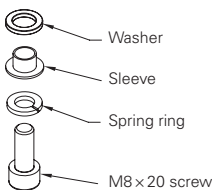

Mounting the locking plate

- ▶ Carry out the learning run for the folding sliding shutter.
- ▶ Close the folding sliding shutter.
- ▶ Position and mark the locking plate.

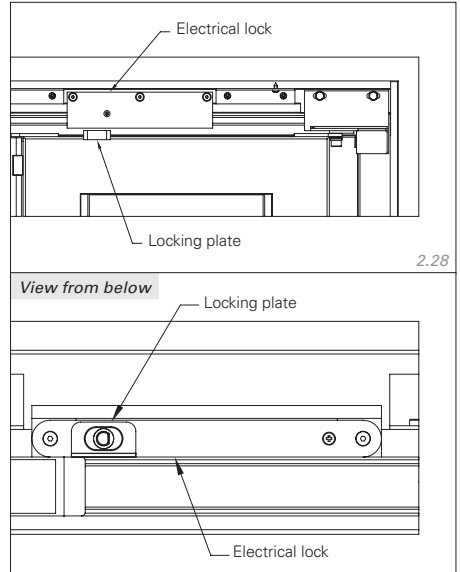

- ▶ Open the folding sliding shutter and align the top stop with the opened sashes.
- ▶ Align the locking plate with the mark and mount

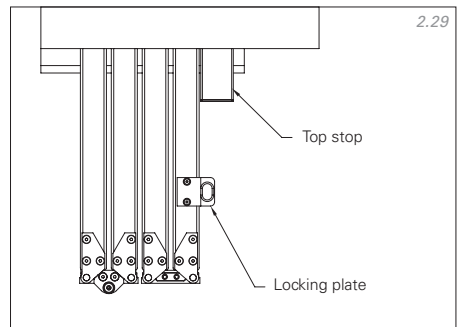

Mounting the cover panel

Motor side

- ▶ Connect the motor and control cables and stow away in the cover panel.
- ▶ Place the cover panel on the motor side and screw into place.

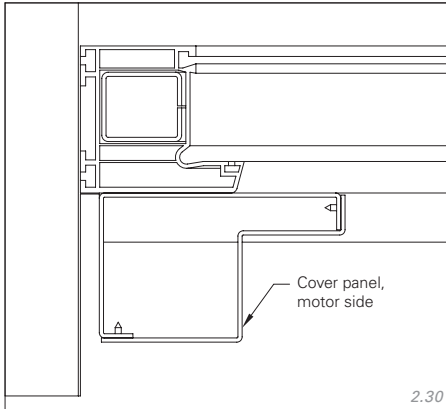

3 Operating instructions

MoveOn connections

230 V folding sliding shutter drive connection

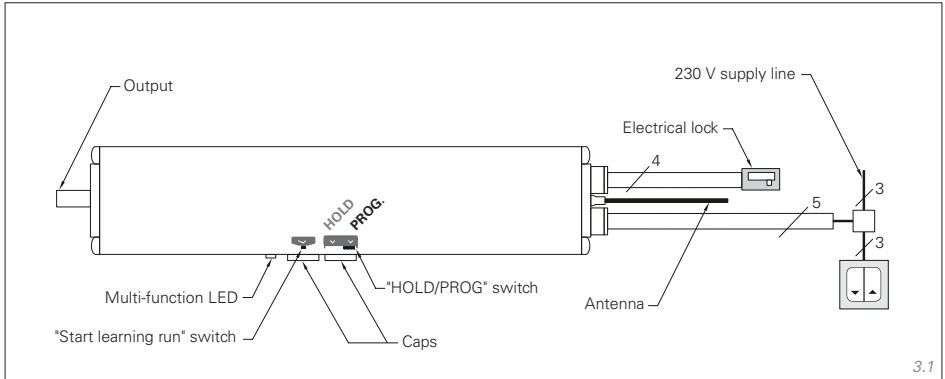

Folding sliding shutter drive

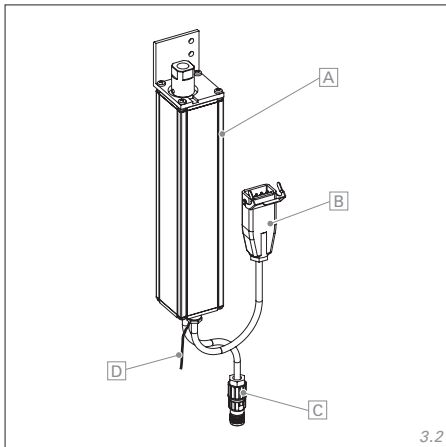

- A Housing
- B Switch supply line
- C Electrical lock
- D Antenna

Mains/switch connection

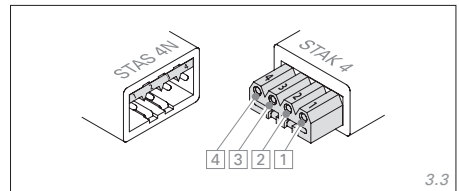

5-pin Hirschmann plug:

- 5 Protective earth (green/yellow)
- 1 L phase mains connection (230 V)
- 2 N neutral conductor mains connection (230 V)
- 3 Signal CLOSE button (230 V)
- 4 Signal OPEN button (230 V)

Electrical lock connection

- 5 Gnd
- 5 +12 V
- 5 Open lock
- 5 Close lock

Wiring diagram

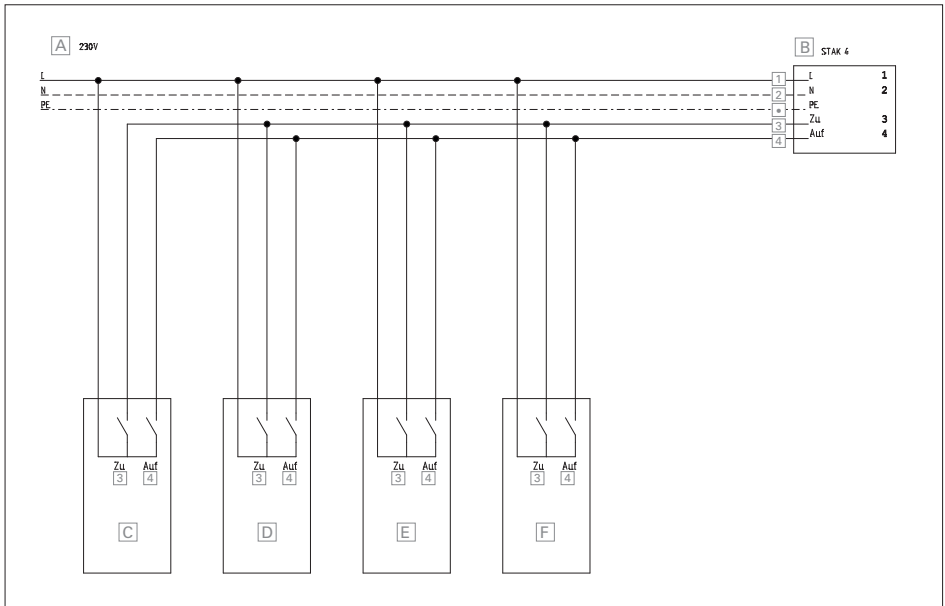

- A Supply cable 230 V
- B Hirschmann coupler Stak 4
- C KNX actor
- D Push-button or switch
- E Timer
- F Sun/wind control
- Earth – protective conductor (green/yellow)
- 1 Mains connection, L-Phase (230 V)
- 2 Mains connection N-neutral conductor (230 V)
- 3 CLOSE-button signal (230 V)
- 4 OPEN-button signal (230 V)

Commissioning

⚠ IMPORTANT

Correct installation

The correct installation of the folding sliding shutter drive may be carried out only by authorised specialist personnel. Only then can complete functionality be guaranteed.

NOTES

Saving settings

To save your programming, always set the switch on the drive to **HOLD**. Only then will the settings be active and unchangeable.



- ▶ Connect the cable 4 to the signal OPEN BUTTON and the cable 3 to the signal CLOSE BUTTON on your switch.

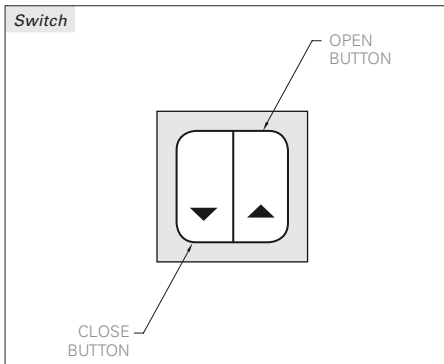

Checking the direction of rotation

- ▶ Press the OPEN BUTTON on the switch.

The folding sliding shutter drive opens automatically. The multi-function LED lights up **green** until the upward travel is complete.

- ▶ Press the CLOSE BUTTON on the switch.

The folding sliding shutter drive closes automatically. The multi-function LED lights up **red** until the downward travel is complete.

The multi-function LED lights up red during upward travel and green during downward travel; the folding sliding shutter opens when pressing the CLOSE BUTTON and closes when pressing the OPEN BUTTON.

- ▶ Change the direction of rotation.

Change direction of rotation

- ▶ Set the switch on the drive to **PROG**.
- ▶ Press and hold the OPEN and CLOSE BUTTONS on the switch simultaneously for approx. 3 seconds.

A brief signal tone sounds and the multi-function LED lights up.

- ▶ Press the OPEN BUTTON twice briefly.

Two signal tones sound, the multi-function LED lights up twice, the direction of rotation changes.

- ▶ Set the switch on the drive to **HOLD**.

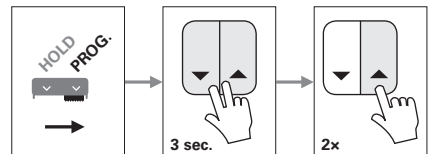

If the direction of rotation has not been changed as desired, please repeat the procedure but:

- ▶ Only press the OPEN BUTTON 1x briefly!

1x = factory default running direction

2x = opposite running direction

Performing a learning run

- ▶ Set the switch on the drive to **PROG.**
- ▶ Remove the cap from the **Start learning run** switch on the drive using a screwdriver.
- ▶ Actuate the **Start learning run** switch on the drive.

The learning run starts.

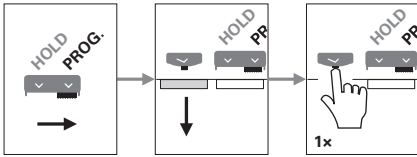

The multi-function LED lights up **yellow** during the learning run. The folding sliding shutter will first open until it is in the open end position and will then slowly close again until it is in the closed end position.

Two brief signal tones sound at the end of the learning run.

- ▶ Set the switch on the drive to **HOLD.**



Master transmitter teaching

NOTES

Master transmitter

- Only one hand-held or wall transmitter can be taught as a master transmitter.
- Do not teach a 1-channel hand-held transmitter to be the master transmitter for more than one product!
- Each channel of a multi-channel hand-held or wall transmitter can be the master transmitter for one control each.
- Each control should be taught on a separate wireless channel.
- The teaching of the master transmitter in the motor must take place at a short distance.
- All further settings can also be undertaken from a greater distance (field of vision).
- In the event that the master transmitter is lost or if a different master transmitter is wanted, then a new transmitter must be taught as the master. Any of the manufacturer's transmitters can be taught as the master transmitter.

Hand-held transmitter (e.g. BlackPearl, 1-channel)

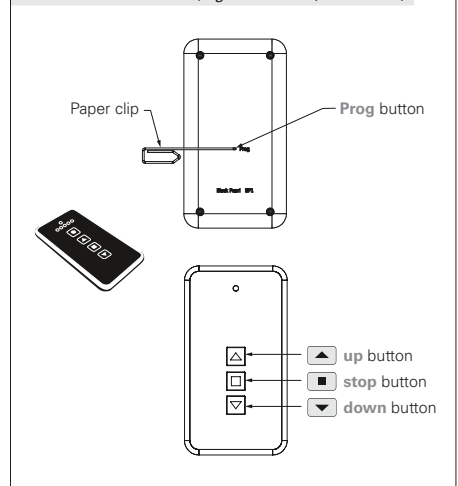

Teaching an additional transmitter

- ▶ Interrupt the power supply to the folding sliding shutter drive for around 10 seconds.
- ▶ Restore the power supply.
- ▶ Press and hold the **Prog** button on the hand-held transmitter at a distance of around 1 m from the folding sliding shutter drive.

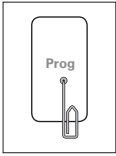

- ▶ Move towards the folding sliding shutter drive until a brief signal tone sounds and the multi-function LED lights up to confirm the connection. (Distance < approx. 40 cm).
- ▶ Press and hold the **up** button on the hand-held transmitter within 2 seconds.

A brief signal tone sounds and the multi-function LED lights up.

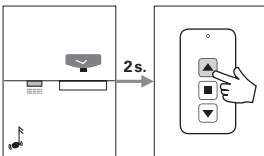

- ▶ Release the button.
- The hand-held transmitter is now programmed as the master transmitter.

- ▶ Set the switch on the drive to **HOLD**.

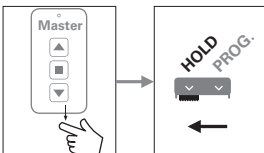

- ▶ Press the **Prog** button on the master transmitter.

A brief signal tone sounds and the multi-function LED lights up (PROGRAMMING MODE).

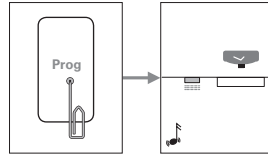

- ▶ Release the **Prog** button on the master transmitter.
- ▶ Press the **up** button on the master transmitter within around 2 seconds.

Uniform signal tones sound and the multi-function LED lights up (LEARNING MODE).

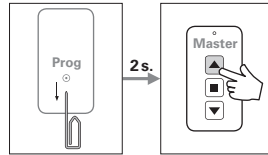

- ▶ Keep the **up** button pressed on the additional transmitter during **LEARNING MODE** (approx. 16 seconds).

The correct programming is confirmed when a brief signal tone sounds (approx. 1 second) and the LED lights up.

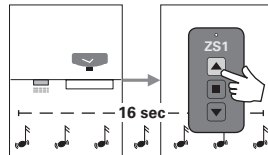

- ▶ Release the button.
- The additional transmitter has now been taught.
- ▶ Set the switch on the drive to **HOLD**.

Clearing an additional transmitter

- ▶ Press the **Prog** button on the master transmitter.

A brief signal tone sounds and the multi-function LED lights up (PROGRAMMING MODE).

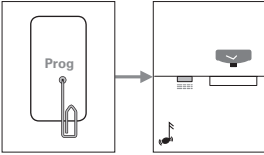

- ▶ Release the **Prog** button on the master transmitter.
- ▶ Press the **down** button on the master transmitter within around 2 seconds.

Fast signal tones sound and the multi-function LED lights up (CLEARING MODE).

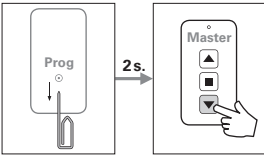

- ▶ Keep the **down** button pressed on the transmitter to be cleared during CLEARING MODE (approx. 16 seconds).

The correct clearing is confirmed when a brief signal tone sounds (approx. 1 second) and the LED lights up.

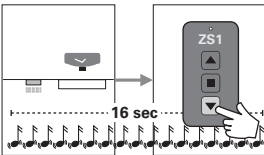

- ▶ Release the button.

The additional transmitter has now been cleared.

- ▶ Set the switch on the drive to **HOLD**.

Clearing all additional transmitters

- ▶ Press the **Prog** button on the master transmitter.

A brief signal tone sounds and the multi-function LED lights up (PROGRAMMING MODE).

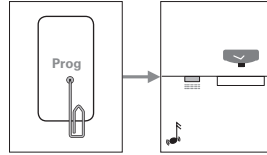

- ▶ Release the **Prog** button on the master transmitter.
- ▶ Press the **down** button on the master transmitter within around 2 seconds.

Fast signal tones sound and the multi-function LED lights up (CLEARING MODE).

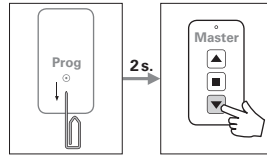

- ▶ Keep the **Prog** button pressed on the master transmitter during CLEARING MODE (approx. 16 seconds).

The correct clearing is confirmed when a brief signal tone sounds (approx. 1 second) and the LED lights up.

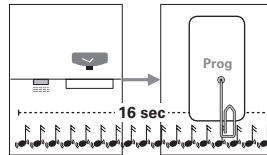

- ▶ Release the button.

All additional transmitters (apart from the master transmitter) are now cleared!

- ▶ Set the switch on the drive to **HOLD**.

EHRET GmbH

Aluminium shutters

Bahnhofstrasse 14-18

77972 Mahlberg, Germany

Tel. + 49 (0) 78 22/439-0

Fax + 49 (0) 78 22/439-116

www.ehret.com