

Technical Information

The energy-generating sliding shutter SolarSlide



EHRET 

Table of Contents

Product Description	4
Frequently Asked Customer Questions & Answers (FAQ)	4
Technical Data – SolarSlide PV Sliding Shutter	6
Technical Drawings	7
Cell Matrix	9

1. Product Description

SolarSlide is an innovative, movable sliding shutter with integrated photovoltaic modules.

It combines three key functions:

- > **Sustainable generation of electricity**
- > **Effective sun protection**
- > **Modern façade design**

The modular system is suitable for both new buildings and refurbishment projects. It gives architects new design freedom when planning energy-efficient buildings, ranging from high-quality residential developments to prestigious commercial properties.

For building owners, SolarSlide is a future-proof solution that helps meet statutory energy standards, unlocks funding opportunities and reduces energy costs over the long term.

Ideally suited for:

- > Single-family homes and residential schemes with a focus on sustainability
- > Office and commercial buildings with high design and performance requirements
- > Renovation projects for energy-efficient façade modernisation
- > Public buildings that demonstrate best practice in climate protection
- > Hotels and resorts with a focus on green building and architecture

2. Frequently Asked Customer Questions & Answers (FAQ)

2.1 What is SolarSlide?

A movable sliding shutter with integrated PV modules for generating electricity and shading. Operated by hand, with optional motorised variant (wireless, push-button, solar).

2.2 What advantages does SolarSlide offer?

- > Generation of electricity from solar energy
- > Reduction in energy costs
- > Effective sun protection and indoor climate control
- > High-quality façade design
- > Contribution to lowering CO₂ emissions and greater sustainability

2.3 How much energy does a SolarSlide PV module generate per m²?

The PV module with an area of 1 m² (1000 mm × 1000 mm) is fitted with 25 monocrystalline cells and, without coating, delivers a rated output of approx. 141.67 Wp (Watt Peak).

2.4 What is the difference between the SolarSlide and SolarSlide Pro?

- > **SolarSlide:** Coloured PV modules in an aluminium frame, cable routing via an energy chain, central inverter provided on site.
- > **SolarSlide Pro:** This version is also fitted with an integrated micro-inverter that allows direct or combined grid feed-in via a 230 V connection (up to 800 Wp, no approval required).

2.5 Is SolarSlide eligible for funding?

Yes, either by applying the zero VAT rate as specified in § 12 para. 3 UStG (German VAT Act) for private households (currently still being clarified), or through regional funding programmes.

2.6 What dimensions are available?

Variant	Shutter panel size (min)	Number of cells	Shutter panel size (max)	Number of cells
SolarSlide (manual)	W=550 mm H=800 mm	> 6	W=1500 mm H=2800 mm	≤ 128
SolarSlide Pro (manual)	W=550 mm H=800 mm	> 35	W=1500 mm H=2800 mm	≤ 128
Motorised operation	W=650 mm			

2.7 Which colours are available?

- > Frame: All RAL K7 colours, including metallic or wood-effect finishes; NCS colours on request
- > Module: 8 standard colours using screen-printing process, special colours on request

Colour	Additional loss due to colour
Full Black (no screen printing)	1–2 %
Anthracite	3 %
Grey	8 %
Light Grey	19 %
Blue	5 %
Green	8 %
Terracotta	20 %
Gold	18 %

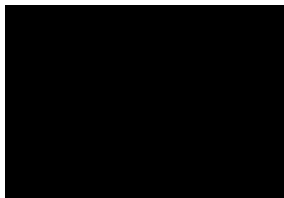

Full Black



Anthracite



Grey



Light Grey



Blue



Green

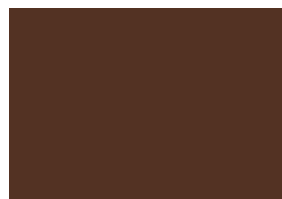

Terracotta



Gold

2.8 What is included in the delivery?

- > Pre-assembled components: Support, panel and shutter fully assembled, motor optional
- > Connection to the electricity:
 - SolarSlide: 4 mm² cable, MC4 connector + matching counterpart beneath the panel
 - SolarSlide Pro: Connection box for 230 V beneath the panel

2.9 How is SolarSlide installed?

- > Specialist contractors take care of the installation.
- > The electrical supply to the property must be set up by a qualified electrician.
- > The shutters can be integrated into façades. The weight of each shutter panel, (approx. 22.57 kg/m² without inverter and mounting plate) must be taken into account in structural calculations.

2.10 How is the generated electricity used?

- > **Up to 2000 Wp module output and 800 Wp feed-in output**, comparable to a balcony solar-powered system, permitted without approval. Registration in the Market Master Data Register is sufficient.
- > **Above 800 Wp feed-in capacity (since 01/03/2025)**: A smart meter and a control box are required. Registration with the grid operator and the Market Master Data Register.

2.11 How is the SolarSlide operated?

- > Manual operation using the guide rails
- > Motorised via remote control or push-button control

2.12 How long is its service life?

- > **Operational guarantee for the modules**
This guarantees that the modules operate at high efficiency over a defined period of 20 years:
 - within 10 years: at least **90 %** of the rated output
 - within 20 years: at least **80 %** of the rated output
- > **Warranty:**
 - **Product warranty:** As per the EHRET Terms and Conditions (TCS) or German Civil Code (BGB) and Construction Contract Procedures (VOB)
 - **Mechanics:** Robust design, low-maintenance and configured for long-term use

2.13 What maintenance does it require?

- > **Cleaning:** 1–2 times annually using water or a mild detergent.
- > **Optional maintenance contract:** For maximum reliability and preservation of value, we recommend taking out a maintenance contract.
- > **Electrical systems:** In accordance with VDE and DGUV standards, to be carried out by a qualified electrician.

3. Technical Data – SolarSlide PV Sliding Shutter

Feature	Details
Module type	PV module with 2 × 4 mm coloured ESG glass, laminated 5BB (5 busbars) monocrystalline cells (158.75 × 158.75 mm), total thickness approx. 9.5 mm.
Power output per 1 m ²	A module with 25 monocrystalline cells at 5.09 Wp achieves a specific output of 127.5 Wp per square metre.
Efficiency	Up to 22%
Weight	Shutter panel weight approx. 22.57 kg/m ² , up to 4.2 m ² per shutter panel maximum
Frame material	Powder-coated aluminium frame, installation depth 48 mm
Guide	Continuous lower guide, Type B or Type D and Type K
Control	Manual, motorised, Smart Home compatible
Type of installation	Surface-mounted installation
Diagram	1R or 1L or 1L+1R
Wind load testing	DIN EN 13659/Wind class in progress
Certifications	CE, VDE, IEC

4. Technical Drawings

4.1 Support panel system

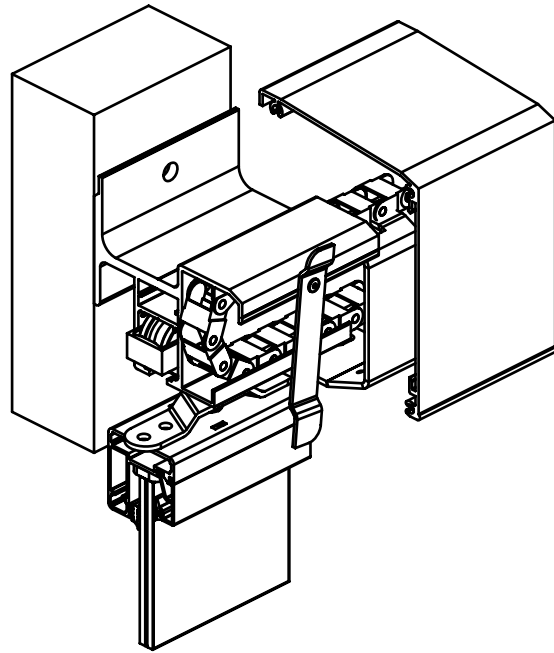
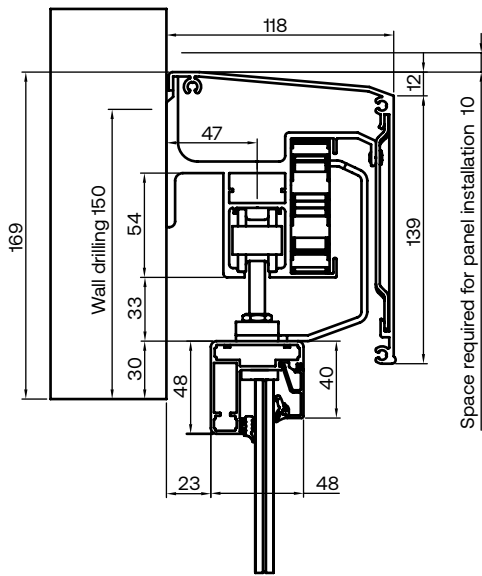

4.2 Frame system BT 48

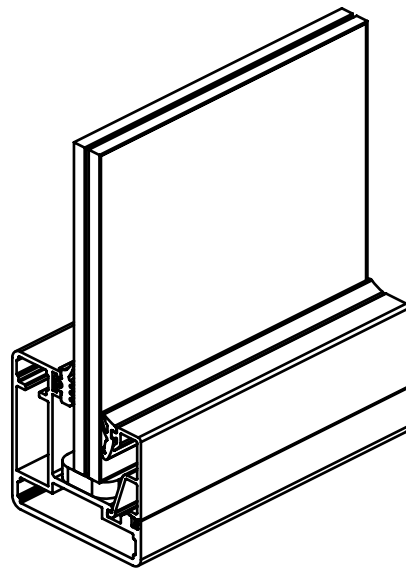
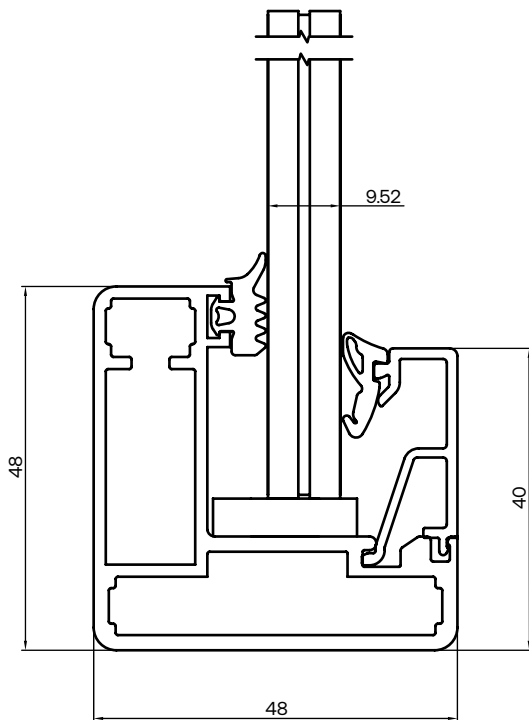

4.3 Lower guide Type B, continuous guide

Distance to wall: 23 mm

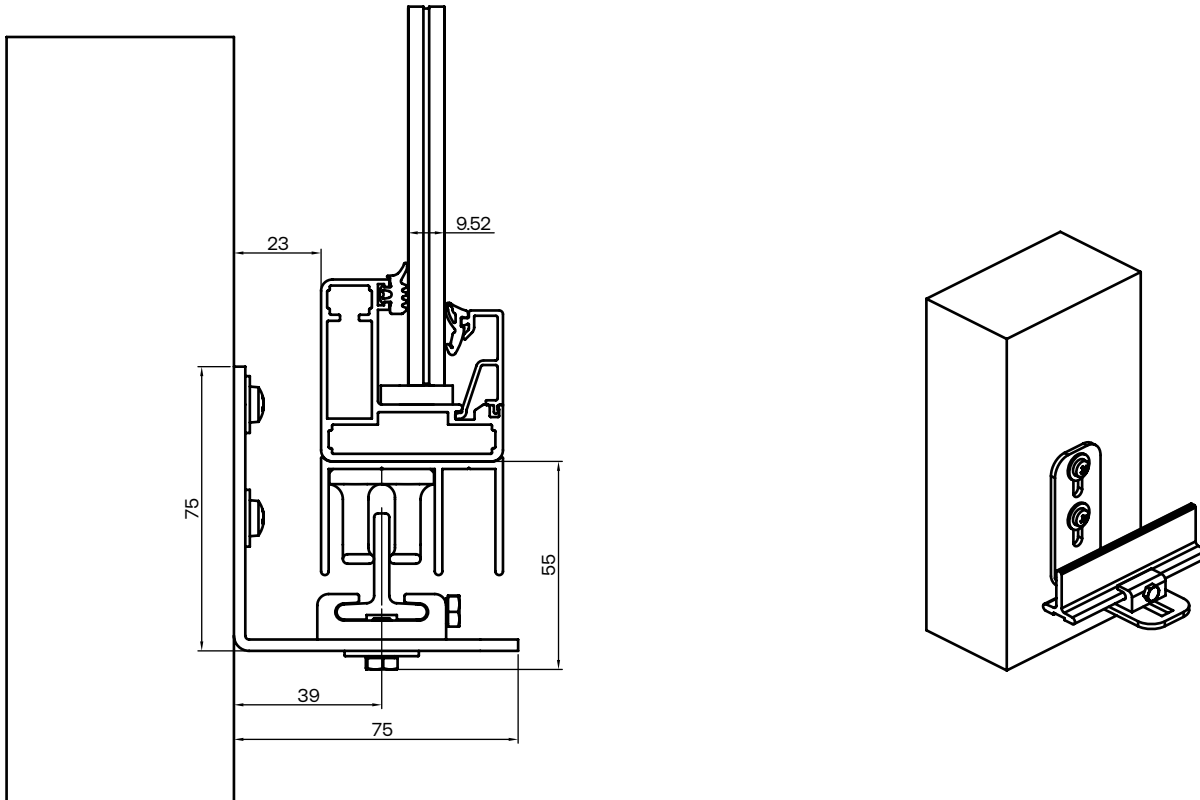

4.4 Positioning of the micro-inverter on the rear of the shutter panel

Finished with aluminium edging

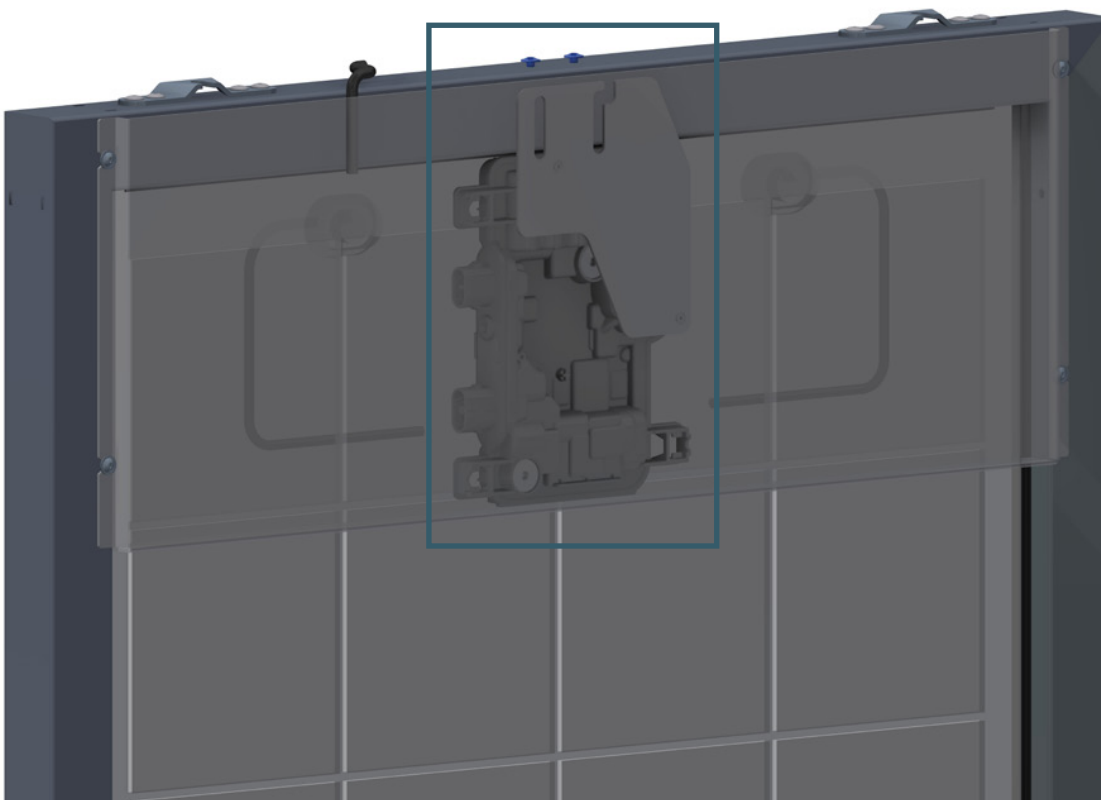

5. Cell Matrix

5.1 Calculation of power based on the cell matrix

Based on the width and height of the shutter panel, the cell matrix shows how many cells are in one module. These measurements not only provide information on the physical size but also on electrical characteristics such as voltage and power (Wp).

The matrix gives a clear overview of how the module dimensions impact energy yield.

Combining the number of cells, voltage and power, indicates:

- > How efficiently the module operates
- > Which applications it is suitable for
- > How size affects the output of power

The actual energy yield of a PV sliding shutter depends on its orientation and position. Factors such as azimuth (horizontal orientation) and cardinal direction influence efficiency and should be considered during planning.

The cell matrix serves as a reference point and technical orientation guide for planning and evaluating electrical systems.

	Width of shutter panel (mm)	550	600	700	800	900	1000	1100	1200	1300	1400	1500
	Height of shutter panel (mm)											
Number of cells		6	6	9	12	12	15	15	18	21	21	24
Power (Wp)	800	31	31	46	61	61	76	76	92	107	107	122
Voltage (V)		3	3	5	7	7	9	9	10	12	12	14
Number of cells		8	8	12	16	16	20	20	24	28	28	32
Power (Wp)	900	41	41	61	82	82	102	102	122	143	143	163
Voltage (V)		5	5	7	9	9	12	12	14	16	16	19
Number of cells		10	10	15	20	20	25	25	30	35	35	40
Power (Wp)	1000	51	51	76	102	102	127	127	153	178	178	204
Voltage (V)		6	6	9	12	12	15	15	17	20	20	23
Number of cells		10	10	15	20	20	25	25	30	35	35	40
Power (Wp)	1100	51	51	76	102	102	127	127	153	178	178	204
Voltage (V)		6	6	9	12	12	15	15	17	20	20	23
Number of cells		12	12	18	24	24	30	30	36	42	42	48
Power (Wp)	1200	61	61	92	122	122	153	153	184	214	214	245
Voltage (V)		7	7	10	14	14	17	17	21	24	24	28
Number of cells		12	12	18	24	24	30	30	36	42	42	48
Power (Wp)	1300	61	61	92	122	122	153	153	184	214	214	245
Voltage (V)		7	7	10	14	14	17	17	21	24	24	28
Number of cells		14	14	21	28	28	35	35	42	49	49	56
Power (Wp)	1400	71	71	107	143	143	178	178	214	250	250	286
Voltage (V)		8	8	12	16	16	20	20	24	28	28	32
Number of cells		16	16	24	32	32	40	40	48	56	56	64
Power (Wp)	1500	82	82	122	163	163	204	204	245	286	286	325
Voltage (V)		9	9	14	19	19	23	23	28	32	32	37
Number of cells		16	16	24	32	32	40	40	48	56	56	64
Power (Wp)	1600	82	82	122	163	163	204	204	245	286	286	326
Voltage (V)		9	9	14	19	19	23	23	28	32	32	37
Number of cells		18	18	27	36	36	45	45	54	63	63	72
Power (Wp)	1700	92	92	138	184	184	229	229	275	321	321	367
Voltage (V)		10	10	16	21	21	26	26	31	37	37	42
Number of cells		18	18	27	36	36	45	45	54	63	63	72
Power (Wp)	1800	92	92	138	184	184	229	229	275	321	321	367
Voltage (V)		10	10	16	21	21	26	26	31	37	37	42
Number of cells		20	20	30	40	40	50	50	60	70	70	80
Power (Wp)	1900	102	102	153	204	204	255	255	306	357	357	408
Voltage (V)		12	12	17	23	23	29	29	35	41	41	46

Width of shutter panel (mm)		550	600	700	800	900	1000	1100	1200	1300	1400	1500
Height of shutter panel (mm)												
Number of cells		22	22	33	44	44	55	55	66	77	77	88
Power (Wp)	2000	112	112	168	224	224	280	280	337	393	393	449
Voltage (V)		13	13	19	26	26	32	32	38	45	45	51
Number of cells		22	22	33	44	44	55	55	66	77	77	88
Power (Wp)	2100	112	112	168	224	224	280	280	337	393	393	449
Voltage (V)		13	13	19	26	26	32	32	38	45	45	51
Number of cells		24	24	36	48	48	60	60	72	84	84	96
Power (Wp)	2200	122	122	184	245	245	306	306	367	428	428	490
Voltage (V)		14	14	21	28	28	35	35	42	49	49	56
Number of cells		24	24	36	48	48	60	60	72	84	84	96
Power (Wp)	2300	122	122	184	245	245	306	306	367	428	428	490
Voltage (V)		14	14	21	28	28	35	35	42	49	49	56
Number of cells		26	26	39	52	52	65	65	78	91	91	104
Power (Wp)	2400	133	133	199	265	265	331	331	398	464	464	530
Voltage (V)		15	15	23	30	30	38	38	45	53	53	60
Number of cells		28	28	42	56	56	70	70	84	98	98	112
Power (Wp)	2500	143	143	214	286	286	357	357	428	500	500	571
Voltage (V)		16	16	24	32	32	41	41	49	57	57	65
Number of cells		28	28	42	56	56	70	70	84	98	98	112
Power (Wp)	2600	143	143	214	286	286	357	357	428	500	500	571
Voltage (V)		16	16	24	32	32	41	41	49	57	57	65
Number of cells		30	30	45	60	60	75	75	90	105	105	120
Power (Wp)	2700	153	153	229	306	306	382	382	459	535	535	612
Voltage (V)		17	17	26	35	35	44	44	52	61	61	70
Number of cells		32	32	48	64	64	80	80	96	112	112	128
Power (Wp)	2800	163	163	245	326	326	408	408	490	571	571	653
Voltage (V)		19	19	28	37	37	46	46	56	65	65	74

Drawings

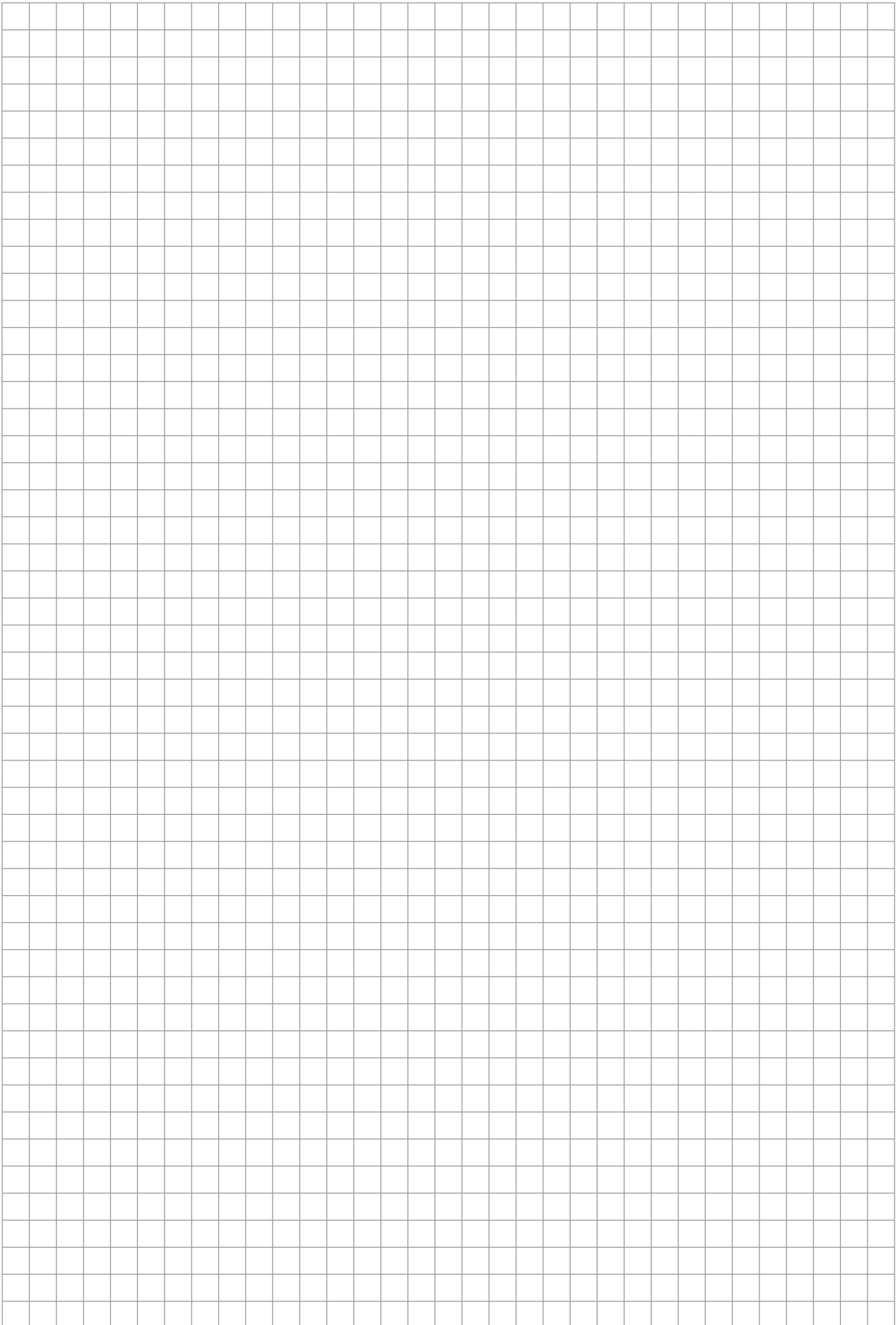

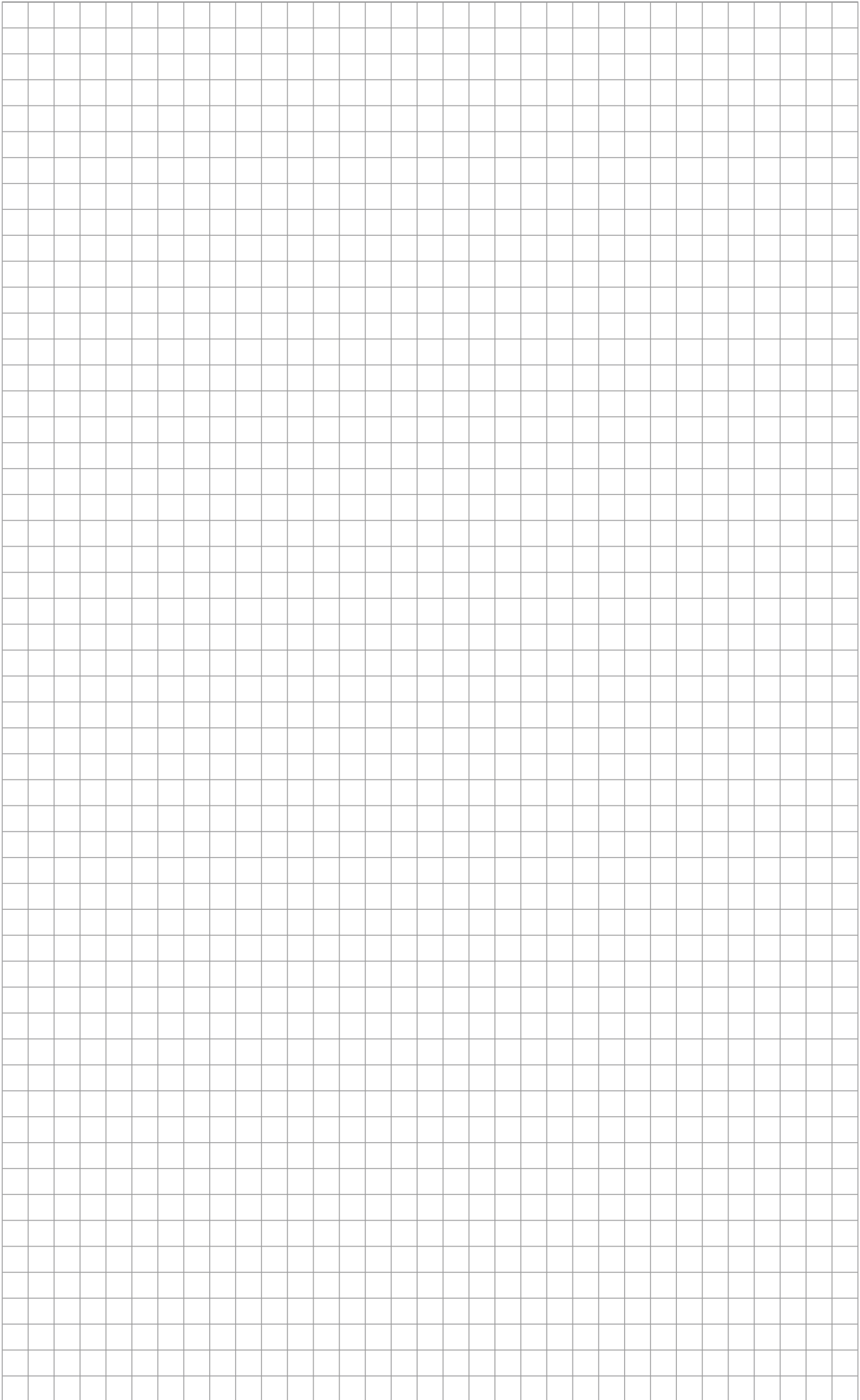

EHRET GmbH

Bahnhofstrasse 14-18
D-77972 Mahlberg

T: +49 (0) 7822 439 0
F: +49 (0) 7822 439 116
info@ehret.com
ehret.com



1.2026/V2

