

SL-MAX70

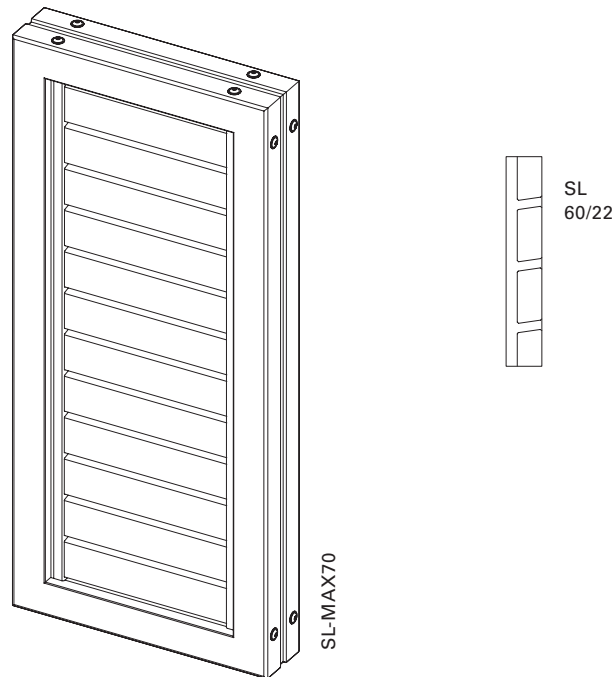

Superficie	Struttura fine opaca (standard), lucida, opaca Verniciatura a polveri a 200 °C prima dell'assemblaggio
Colori	RAL Classic, RAL Design, NCS, VSR
Finiture	Legno, pietra, ruggine
Pretrattamento	Ocean Line Plus possibile
Note	Foro di drenaggio in basso nel telaio Lamelle intercambiabili

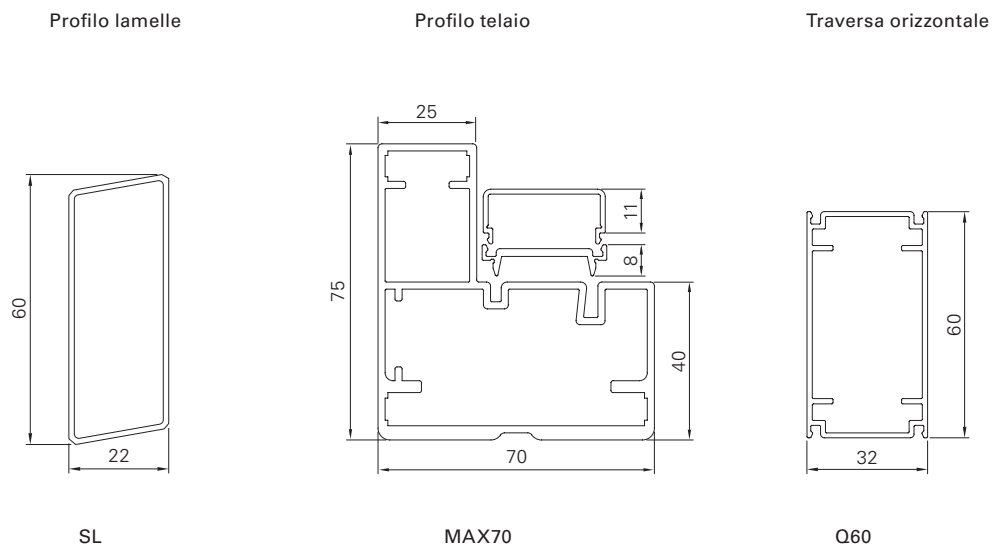



Misure min./max.	Larghezza: da 550 a 2200 mm Altezza: da 800 a 5500 mm
Avanzamento min./max.	Circa 70,0–80,0 mm
Angolo di inclinazione	90°
Peso	Circa 16 kg/m ²
Profilo telaio	Profilo a camera cava in alluminio estruso 75 × 70 mm
Profilo lamelle	Profilo a camera cava in alluminio estruso 60 × 22 mm
Profilo portante lamelle	Alluminio estruso 32 × 11 mm
Profilo intermedio	Alluminio estruso 32 × 8 mm
Profilo traversa orizzontale	Profilo a camera cava in alluminio estruso 60 × 32 mm

Collegamenti angolari Squadra di alluminio incollata e avvitata

Opzioni Traversa longitudinale | Traversa orizzontale | Catenaccio persiana scorrevole | Azionamento elettrico